

DR Series

DR... Variable Frequency Drives (VFDs)

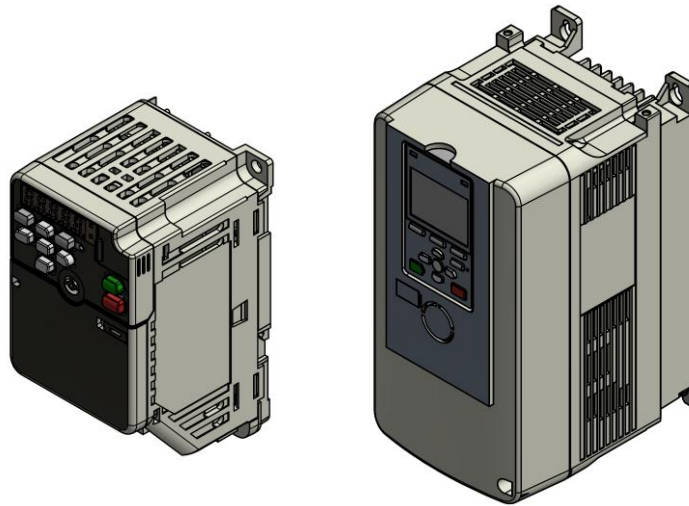

Description

DR... series VFDs precisely control the speed of an AC induction motor. VFDs are pre-programmed for each application to simplify installation.

Features

- 1/6 to 200 HP VFDs available
- High resolution multi-language display
- Open loop vector or volts/hertz control
- USB port for PC connection to monitor drive performance or adjust parameters
- Bluetooth connection standard on GA800 drives
- Parameter backup capability
- 240V and 480V available

Application

The primary use of DR... series variable frequency drives is to control the speed of blowers used with LMV3 and LMV5 burner controls.

Product Part Numbers

The part number structure for DR... drives is shown below. Not all part number variations are possible. See Product Part Number Tables for available options.

DR - 480 040 - 3 B

Model

Operating Voltage

240 = 240 VAC

480 = 480 VAC

Motor Horsepower

F16 = 1/6 HP

F14 = 1/4 HP

F12 = 1/2 HP

F34 = 3/4 HP

001 = 1 HP

002 = 2 HP

003 = 3 HP

005 = 5HP

007 = 7.5 HP

010 = 10 HP

015 = 15 HP

020 = 20 HP

025 = 25 HP

030 = 30 HP

040 = 40 HP

050 = 50 HP

060 = 60 HP

075 = 75 HP

100 = 100 HP

125 = 125 HP

150 = 150 HP

200 = 200 HP

Input Phase

1 = Single Phase (240 VAC)

3 = Three Phase (240 VAC, 480 VAC)

Drive Model

B = GA500 Drive

C = GA800 Drive

Product Part Numbers (continued)

DR... series part numbers and ratings are tabulated below.

Table 1: 240V Single Phase Drives (10% Braking Resistor)

Drive Part Number	HP	Amps	Model	NEMA 1 Kits ⁽¹⁾	Braking Resistor Part Number ⁽²⁾	Resistor Enclosure Size ⁽³⁾	Line Reactor Part Number ⁽⁴⁾	Load Reactor Part Number ⁽⁴⁾
DR-240F16-1B	1/6	1.2	GA500	DRN1-B1-1	DRBKG-2024-1-F16-1	GCE2	DRLR-2024-1-F16-1	DRMR-2024-1-F16-1
DR-240F14-1B	1/4	1.9			DRBKG-2024-1-F14-1	GCE1	DRLR-2024-1-F14-1	DRMR-2024-1-F14-1
DR-240F34-1B	3/4	3.3		DRN1-B1-2	DRBKG-2024-1-F34-1	GCE1	DRLR-2024-1-F34-1	DRMR-2024-1-F34-1
DR-240001-1B	1	6.0		DRN1-B2-1	DRBKG-2024-1-1-1	GCE1	DRLR-2024-1-1-1	DRMR-2024-1-1-1
DR-240002-1B	2	9.6		DRN1-B2-2	DRBKG-2024-1-2-1	GCE1	DRLR-2024-1-2-1	DRMR-2024-1-2-1
DR-240003-1B	3	12		DRN1-B3-1	DRBKG-2024-1-3-1	GCE1	DRLR-2024-1-3-1	DRMR-2024-1-3-1
DR-240005-1B	5	17.6		DRN1-B4-1	DRBKG-2024-1-5-1	GCE2	DRLR-2024-1-5-1	DRMR-2024-1-5-1

¹ Optional part – Must be ordered separately. Required for mounting outside of an enclosure.² Optional part – Must be ordered separately. Typically required with fast ramp times (60 seconds or less) and/or large, heavy blower wheels.³ For reference dimensions – see page 22⁴ Optional part – must be ordered separately. See pages 8-10 for more information regarding the use of line/load reactors.**Table 2: 240V Three Phase Drives (10% Braking Resistor)**

Drive Part Number	HP	Amps	Model	NEMA 1 Kits ⁽¹⁾	Braking Resistor Part Number ⁽²⁾	Resistor Enclosure Size ⁽³⁾	Braking Unit ⁽⁴⁾	Line Reactor Part Number ⁽⁵⁾	Load Reactor Part Number ⁽⁵⁾
DR-240F16-3B	1/6	1.2	GA500	DRN1-B1-1	DRBKG-2024-3-F16-1	GCE2	-	DRLR-2024-3-F16-1	DRMR-2024-3-F16-1
DR-240F14-3B	1/4	1.9			DRBKG-2024-3-F14-1	GCE1	-	DRLR-2024-3-F14-1	DRMR-2024-3-F14-1
DR-240F34-3B	3/4	3.5			DRBKG-2024-3-F34-1	GCE1	-	DRLR-2024-3-F34-1	DRMR-2024-3-F34-1
DR-240001-3B	1	6.0			DRBKG-2024-3-1-1	GCE1	-	DRLR-2024-3-1-1	DRMR-2024-3-1-1
DR-240002-3B	2	9.6		DRN1-B2-3	DRBKG-2024-3-2-1	GCE1	-	DRLR-2024-3-2-1	DRMR-2024-3-2-1
DR-240003-3B	3	9.6			DRBKG-2024-3-3-1	GCE1	-	DRLR-2024-3-3-1	DRMR-2024-3-3-1
DR-240005-3B	5	21		DRN1-B3-2	DRBKG-2024-3-5-1	GCE2	-	DRLR-2024-3-5-1	DRMR-2024-3-5-1
DR-240007-3B	7.5	21			DRBKG-2024-3-7.5-1	GCE2	-	DRLR-2024-3-7.5-1	DRMR-2024-3-7.5-1
DR-240010-3B	10	30		DRN1-B5-1	DRBKG-2024-3-10-1	GCE3	-	DRLR-2024-3-10-1	DRMR-2024-3-10-1
DR-240015-3B	15	42			DRBKG-2024-3-15-1	GCE4	-	DRLR-2024-3-15-1	DRMR-2024-3-15-1
DR-240020-3B	20	56		DRN1-B6-1	DRBKG-2024-3-20-1	GCE9	-	DRLR-2024-3-20-1	DRMR-2024-3-20-1
DR-240025-3B	25	70		DRN1-B7-1	DRBKG-2024-3-25-1	GCE9	-	DRLR-2024-3-25-1	DRMR-2024-3-25-1
DR-240030-3B	30	82			DRBKG-2024-3-30-1	GCE9	-	DRLR-2024-3-30-1	DRMR-2024-3-30-1
DR-240040-3C	40	110		GA800	DRN1-C1-5	DRBKG-2024-3-40-1	GCE6	-	DRLR-2024-3-40-1
DR-240050-3C	50	138	DRN1-C1-6		DRBKG-2024-3-50-1	GCE9	-	DRLR-2024-3-50-1	DRMR-2024-3-50-1
DR-240060-3C	60	169	DRN1-C1-7		DRBKG-2024-3-60-1 ⁽⁴⁾	GCE9	DRUN-2024-3-60-1	DRLR-2024-3-60-1	DRMR-2024-3-60-1
DR-240075-3C	75	211	DRN1-C1-8		DRBKG-2024-3-75-1 ⁽⁴⁾	GCE9	DRUN-2024-3-75-1	DRLR-2024-3-75-1	DRMR-2024-3-75-1
DR-240100-3C	100	257	DRN1-C1-9		DRBKG-2024-3-100-1 ⁽⁴⁾	GCE12	DRUN-2024-3-100-1	DRLR-2024-3-100-1	DRMR-2024-3-100-1

¹ Optional part – must be ordered separately. Required for mounting outside of an enclosure.² Optional part – must be ordered separately. Typically required with fast ramp times (60 seconds or less) and/or large, heavy blower wheels.³ For Reference Dimensions – see page 22⁴ 240V GA800 drives with 60HP or more require a braking unit if ordering a braking resistor.⁵ Optional part – must be ordered separately. See pages 8-10 for more information regarding the use of line/load reactors.

Product Part Numbers (continued)

Table 3: 480V Three Phase Drives (10% Braking Resistors)

Drive Part Number	HP	Amps	Drive Model	NEMA 1 Kits ⁽¹⁾	Resistor Part Number ⁽²⁾	Resistor Enclosure Size ⁽³⁾	Braking Unit ⁽⁴⁾	Line Reactor Part Number ⁽⁵⁾	Load Reactor Part Number ⁽⁵⁾	
DR-480F12-3B	1/2	1.2	GA500	DRN1-B2-4	DRBKG-3848-3-F12-1	GCE2	-	DRLR-3848-3-F12-1	DRMR-3848-3-F12-1	
DR-480001-3B	1	2.1			DRBKG-3848-3-1-1	GCE2	-	DRLR-3848-3-1-1	DRMR-3848-3-1-1	
DR-480002-3B	2	4.1		DRN1-B2-5	DRBKG-3848-3-2-1	GCE2	-	DRLR-3848-3-2-1	DRMR-3848-3-2-1	
DR-480003-3B	3	5.4			DRBKG-3848-3-3-1	GCE1	-	DRLR-3848-3-3-1	DRMR-3848-3-3-1	
DR-480005-3B	5	8.9		DRN1-B2-2	DRBKG-3848-3-5-1	GCE1	-	DRLR-3848-3-5-1	DRMR-3848-3-5-1	
DR-480007-3B	7.5	11.9			DRBKG-3848-3-7.5-1	GCE2	-	DRLR-3848-3-7.5-1	DRMR-3848-3-7.5-1	
DR-480010-3B	10	17.5		DRN1-B5-1	DRBKG-3848-3-10-1	GCE4	-	DRLR-3848-3-10-1	DRMR-3848-3-10-1	
DR-480015-3B	15	23.4			DRBKG-3848-3-15-1	GCE4	-	DRLR-3848-3-15-1	DRMR-3848-3-15-1	
DR-480020-3B	20	31.0		DRN1-B6-1	DRBKG-3848-3-20-1	GCE6	-	DRLR-3848-3-20-1	DRMR-3848-3-20-1	
DR-480025-3B	25	38.0			DRBKG-3848-3-25-1	GCE8	-	DRLR-3848-3-25-1	DRMR-3848-3-25-1	
DR-480030-3B	30	44.0		DRN1-B8-1	DRBKG-3848-3-30-1	GCE8	-	DRLR-3848-3-30-1	DRMR-3848-3-30-1	
DR-480040-3B	40	60.0			DRBKG-3848-3-40-1	GCE9	-	DRLR-3848-3-40-1	DRMR-3848-3-40-1	
DR-480050-3C	50	74.9		GA800	DRN1-C1-5	DRBKG-3848-3-50-1	GCE6	-	DRLR-3848-3-50-1	DRMR-3848-3-50-1
DR-480060-3C	60	89.2				DRBKG-3848-3-60-1	GCE9	-	DRLR-3848-3-60-1	DRMR-3848-3-60-1
DR-480075-3C	75	103			DRN1-C1-6	DRBKG-3848-3-75-1	GCE12	-	DRLR-3848-3-75-1	DRMR-3848-3-75-1
DR-480100-3C	100	140				DRBKG-3848-3-100-1	GCE15	-	DRLR-3848-3-100-1	DRMR-3848-3-100-1
DR-480125-3C	125	168	DRN1-C1-7		DRBKG-3848-3-125-1	GCE18	-	DRLR-3848-3-125-1	DRMR-3848-3-125-1	
DR-480150-3C	150	208			DRBKG-3848-3-150-1 ⁽⁴⁾	GCE18	DRUN-3848-3-150-1	DRLR-3848-3-150-1	DRMR-3848-3-150-1	
DR-480200-3C	200	250	DRN1-C1-9		DRBKG-3848-3-200-1 ⁽⁴⁾	GCE24	DRUN-3848-3-200-1	DRLR-3848-3-200-1	DRMR-3848-3-200-1	

General Note:

GA800 drives greater than 200HP are available if required. Contact SCC Inc. for more information.

Specific Notes:

¹ Optional part – must be ordered separately. Required for mounting outside of an enclosure.

² Optional part – must be ordered separately. Typically required with fast ramp times (60 seconds or less) and/or large, heavy blower wheels.

³ For Reference Dimensions – see page 22

⁴ 480V GA800 drives with 150 to 200HP require a braking unit if ordering a braking resistor.

⁵ Optional part – must be ordered separately. See pages 8-10 for more information regarding the use of line/load reactors.

Accessories

DR-RMK-500-1

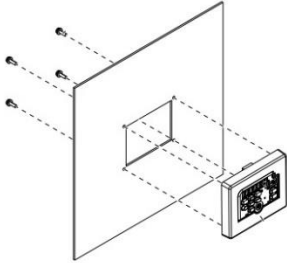

A remote viewing kit for any GA500 VFD. The purpose of this kit is to view the VFD's display when the VFD is mounted inside an enclosure. This kit includes the following components:

- A mounting kit to mount the LED keypad to the outside of the GA500 enclosure
- A 3m long cable to connect the LED keypad to the GA500 VFD
- A blank cover to be installed on the GA500 VFD in place of the LED keypad

Specifications

Overload: Drive Duty Mode [Normal Duty]	110% of rated output current for duration of 60 seconds. Can occur once every 10 minutes.
HP Ratings	1/6 to 200HP
Amperage Ratings	1.2 to 257A
Carrier Frequency	
Drive GA500	2 kHz without derating drive capacity
Drive GA800 [240V, 480V: 1-75HP]	Derating drive capacity to 15kHz maximum
Drive GA800 [480V: 100-200HP]	2 kHz without derating drive capacity Derating drive capacity to 10kHz maximum
Input: Power Supply	
Permitted Voltage Fluctuation	-15% to +10%
Permitted Frequency Fluctuation	+/- 5%
Protection Design	IP20 (inside use) In area without oil, mist, corrosive or flammable gas, dust, water, salt, and direct sunlight
Safety Functions	
Thermal Overload Overload	Selective Output current of 110%+ for 60 seconds
Voltage Protection Limits	Single Phase 240V: 160-410V Three Phase 240V: 190V-410V Three Phase 480V: 380V-820V
Installation Orientation	Vertical (for sufficient airflow to cool the drive)
Ambient Temperature	14 °F to 122 °F [-10 °C to 50 °C]
Storage Temperature	-4 °F to 158 °F [-20 °C to 70 °C]

Functions of Braking Resistors, Line Reactors, and Load Reactors

Braking Resistors

Three-phase AC induction motors can also function as three-phase AC generators if they become driven by what they typically drive. In the case of a blower, the motor drives the blower wheel when the speed of the wheel is increased (accelerated). Conversely, the blower wheel can drive the motor when the speed of the blower wheel is decreased (decelerated) with a closed air damper. When the motor is driven by the blower wheel, it will act as a generator and "push" electrical energy back to the VFD. This energy will be seen as a voltage increase on the VFD's DC bus.

The DC bus can absorb a small amount of energy in the DC bus capacitors. However, if the motor generates more than what these capacitors can absorb, the DC bus voltage will rise to critical levels and one of two actions will be taken by the VFD. Depending on the parameter setting of the VFD, the VFD will either stop decelerating (stall prevention) or the VFD will alarm and shut down. Either one of the actions is not a desirable result on a combustion air application.

To avoid DC bus overvoltage issues, a braking resistor can be added to the VFD so that the excess electrical energy generated by decelerating the blower wheel can be turned to heat. This process happens seamlessly so that the VFD can decelerate the blower smoothly.

Due to a number of variables, it is difficult to determine if a braking resistor will be needed on a particular application unless that application has been tested. The only disadvantage of having a braking resistor and not needing it is cost and possibly the space for the resistor. Burners having the following characteristics will typically need a braking resistor:

1. A heavy blower wheel - Kinetic energy is stored in a spinning wheel. The heavier the blower wheel, the greater the stored energy. When this wheel is slowed down, the kinetic energy must go somewhere, and it is usually "pushed" back to the VFD as electrical energy.
2. Fast ramp times - The faster the ramp times, the faster the blower wheel must be accelerated and decelerated. Just like a car, more energy is required to accelerate quickly (bigger engine) and more energy is required to be dissipated when decelerating quickly (bigger brakes). Decelerating a given blower wheel more quickly will push more electrical energy back to the VFD.
3. Closed air damper - A motor spinning at 3600 RPM draws fewer amps with a closed or nearly closed air damper as compared to an open air damper. Thus, the horsepower used by the motor and the drag (braking) on the blower wheel will be much less with a closed or

Functions of Braking Resistors, Line Reactors, and Load Reactors (continued)

nearly closed air damper. Decelerating a given blower wheel with reduced drag will also push more electrical energy back to the VFD.

The above points compound one another. Decelerating a heavy blower wheel with a fast ramp time and a mostly closed air damper will push a large amount of electrical energy back at the VFD and will likely cause DC bus overvoltage issues if a braking resistor is not installed.

In contrast, a light blower wheel (sheet metal instead of cast iron), a slower ramp time (90 seconds instead of 30 seconds), and slowing the blower down on an open air damper are characteristics that will greatly reduce the amount of electrical energy pushed back to the VFD and should allow the braking resistor to be omitted in most cases.

Line Reactors

Line reactors, or "chokes", are typically used when the impedance on the input side of the drive is low. Impedance on the input side of the drive is typically low when a relatively small VFD is being fed by a relatively large transformer. In this situation, the supply side of the drive is "stiff", meaning that an instantaneous current draw by the drive will be met very quickly by the large transformer (think square wave form), causing voltage and current distortions in the power distribution system feeding the drive. In this situation, adding a line reactor will add reactance which opposes instantaneous current draw and "softens" the input side of the drive.

Conversely, if the transformer feeding the drive is not large relative to the drive, the impedance on the input side of the drive is higher and the system is "softer". In this situation, an instantaneous current draw by the drive will not be met as quickly, and the resulting voltage and current distortions in the power distribution system feeding the drive will be smaller. An additional line reactor in this situation is not needed.

Functions of Braking Resistors, Line Reactors, and Load Reactors (continued)

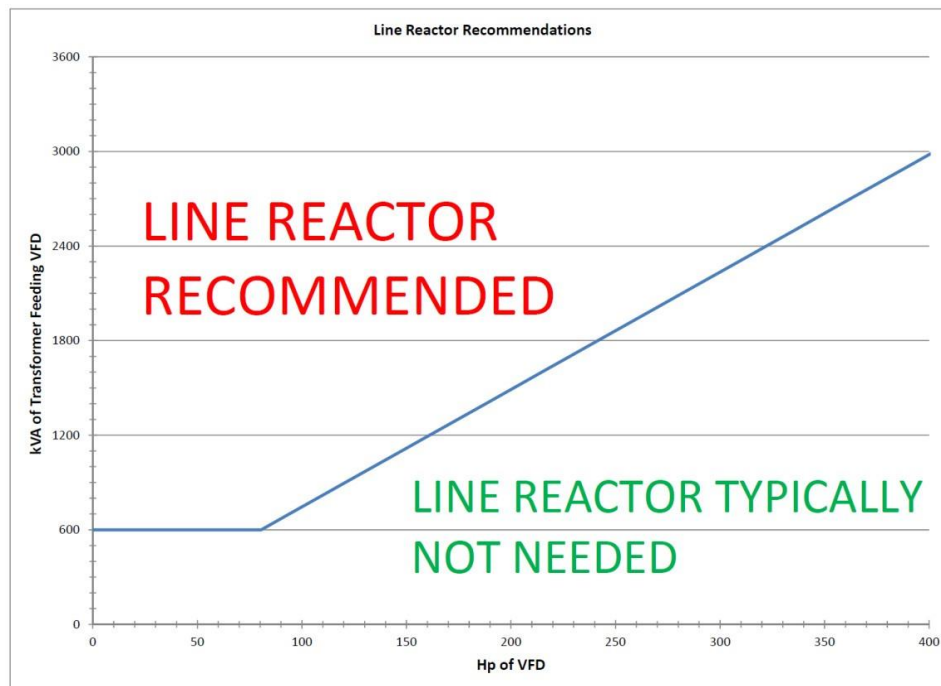

Figure 1: Line Reactor Recommendation – VFD (HP) vs Transformer (kVA)

In general, a line reactor is recommended if the supply capacity (kVA) of the transformer feeding the drive is greater than or equal to 10 times the capacity (kVA) of the drive for transformers 600 kVA and larger.

Load Reactors and Output Wiring

When the VFD / motor are running, high levels of electrical noise are produced on the wiring between the VFD and the motor. This is due to the fact that modified sine waves produced by the drive IGBTs are basically high frequency / high voltage DC pulses. These output wires must be enclosed in some type of shielding (metallic conduit or metal-shielded cable) to mitigate radiated electrical noise.

Wire length between the VFD and the motor should be kept to less than 150 feet if possible due to the reflected wave / standing wave phenomenon and voltage overshooting. Both of these phenomena are rather complex, and are a function of the wire length from the VFD to the motor. The reflected wave / standing wave phenomenon and voltage overshoot phenomenon can damage non-inverter duty motor windings over time due to the high peak voltages that these phenomena can produce.

Functions of Braking Resistors, Line Reactors, and Load Reactors (continued)

NOTE: The DC bus runs at voltages substantially higher than the incoming voltage to the drive (about 35% higher) and typically employs large capacitors. These capacitors remain charged for a period of time after the incoming power to the drive is de-energized, and are a shock hazard until they discharge.

If wire length cannot be kept to less than 150 feet on the drive output, correction options are available.

Table 4: Correction Options for Long Wire Length between VSD and Motor

Wire Length – up to (ft)	Correction Option
150	None Required
300	Load Reactor at VFD Output
650	Load Reactor at Motor Input
2000	dV/dT Filter on VFD Output ⁽¹⁾
> 2000 (Consult Motor OEM)	Inverter Duty Motor

¹ Type of low pass filter. Contact SCC for additional information.

Dimensions

Dimensions in inches [mm]

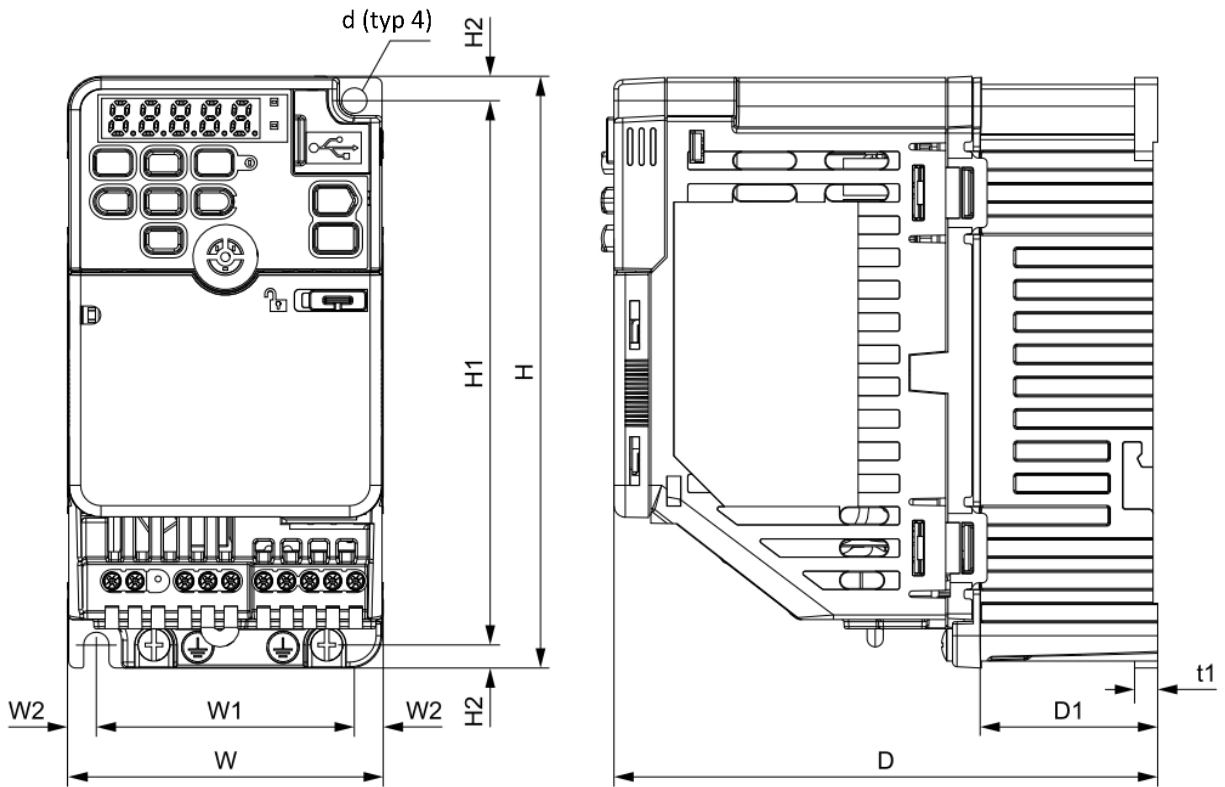

Table 5: GA500 Diagram 1

Model	W	H	H*	W1	W2	H1	H2	D	D1	t1	d
DR-240F16-1B	2.68 [68]	5.04 [128]	6.22 [158]	2.20 [56]	0.24 [6]	4.65 [118]	0.20 [5]	2.99 [76]	0.26 [6.5]	0.12 [3]	#10 (M5)
DR-240F14-1B	2.68 [68]	5.04 [128]	6.22 [158]	2.20 [56]	0.24 [6]	4.65 [118]	0.20 [5]	2.99 [76]	0.26 [6.5]	0.12 [3]	#10 (M5)
DR-240F34-1B	2.68 [68]	5.04 [128]	6.22 [158]	2.20 [56]	0.24 [6]	4.65 [118]	0.20 [5]	4.65 [118]	1.52 [38.5]	0.20 [5]	#10 (M5)
DR-240F16-3B	2.68 [68]	5.04 [128]	6.22 [158]	2.20 [56]	0.24 [6]	4.65 [118]	0.20 [5]	2.99 [76]	0.26 [6.5]	0.12 [3]	#10 (M5)
DR-240F14-3B	2.68 [68]	5.04 [128]	6.22 [158]	2.20 [56]	0.24 [6]	4.65 [118]	0.20 [5]	2.99 [76]	0.26 [6.5]	0.12 [3]	#10 (M5)
DR-240F34-3B	2.68 [68]	5.04 [128]	6.22 [158]	2.20 [56]	0.24 [6]	4.65 [118]	0.20 [5]	4.25 [108]	1.52 [38.5]	0.20 [5]	#10 (M5)
DR-240001-3B	2.68 [68]	5.04 [128]	6.22 [158]	2.20 [56]	0.24 [6]	4.65 [118]	0.20 [5]	5.04 [128]	2.30 [58.5]	0.20 [5]	#10 (M5)

* Total height of the VFD if installing the NEMA 1 kit (not shown)

Dimensions (continued)

Dimensions in inches [mm]

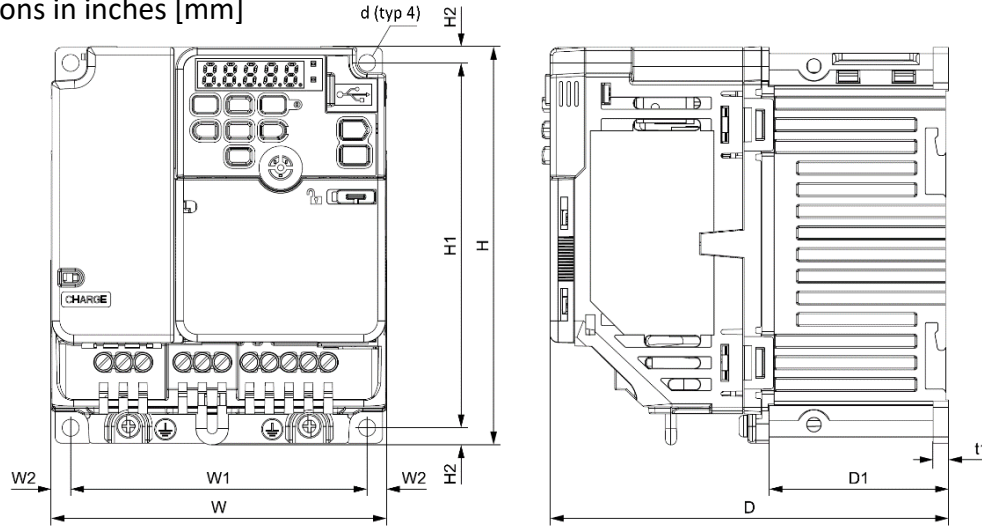

Table 6: GA500 Diagram 2

Model	W	H	H*	W1	W2	H1	H2	D	D1	t1	d
DR-240001-1B	4.25 [108]	5.04 [128]	7.40 [188]	3.78 [96]	0.24 [6]	4.65 [118]	0.20 [5]	5.41 [138]	2.22 [56.5]	0.20 [5]	#10 (M5)
DR-240002-1B	4.25 [108]	5.04 [128]	7.40 [188]	3.78 [96]	0.24 [6]	4.65 [118]	0.20 [5]	6.06 [154]	2.22 [56.5]	0.20 [5]	#10 (M5)
DR-240003-1B	5.51 [140]	5.04 [128]	7.40 [188]	5.04 [128]	0.24 [6]	4.65 [118]	0.20 [5]	6.42 [164]	2.56 [65]	0.20 [5]	#10 (M5)
DR-240005-1B	6.69 [170]	5.04 [128]	7.22 [184]	6.22 [158]	0.24 [6]	4.65 [118]	0.20 [5]	7.09 [180]	2.56 [65]	0.20 [5]	#10 (M5)
DR-240002-3B	4.25 [108]	5.04 [128]	7.40 [188]	3.78 [96]	0.24 [6]	4.65 [118]	0.20 [5]	5.08 [129]	2.22 [56.5]	0.20 [5]	#10 (M5)
DR-240003-3B	4.25 [108]	5.04 [128]	7.40 [188]	3.78 [96]	0.24 [6]	4.65 [118]	0.20 [5]	5.41 [138]	2.22 [56.5]	0.20 [5]	#10 (M5)
DR-240005-3B	5.51 [140]	5.04 [128]	7.40 [188]	5.04 [128]	0.24 [6]	4.65 [118]	0.20 [5]	5.63 [143]	2.56 [65]	0.20 [5]	#10 (M5)
DR-480F12-3B	4.25 [108]	5.04 [128]	6.26 [159]	3.78 [96]	0.24 [6]	4.65 [118]	0.20 [5]	3.19 [81]	0.33 [8.5]	0.20 [5]	#10 (M5)
DR-480001-3B	4.25 [108]	5.04 [128]	6.26 [159]	3.78 [96]	0.24 [6]	4.65 [118]	0.20 [5]	3.90 [99]	1.04 [26.5]	0.20 [5]	#10 (M5)
DR-480002-3B	4.25 [108]	5.04 [128]	6.26 [159]	3.78 [96]	0.24 [6]	4.65 [118]	0.20 [5]	5.41 [138]	2.22 [56.5]	0.20 [5]	#10 (M5)
DR-480003-3B	4.25 [108]	5.04 [128]	7.40 [188]	3.78 [96]	0.24 [6]	4.65 [118]	0.20 [5]	6.06 [154]	2.22 [56.5]	0.20 [5]	#10 (M5)
DR-480005-3B	4.25 [108]	5.04 [128]	7.40 [188]	3.78 [96]	0.24 [6]	4.65 [118]	0.20 [5]	6.06 [154]	2.22 [56.5]	0.20 [5]	#10 (M5)
DR-480007-3B	5.51 [140]	5.04 [128]	7.40 [188]	5.04 [128]	0.24 [6]	4.65 [118]	0.20 [5]	5.63 [143]	2.56 [65]	0.20 [5]	#10 (M5)

* Total height of the VFD if installing the NEMA 1 kit (not shown)

Dimensions (continued)

Dimensions in inches [mm]

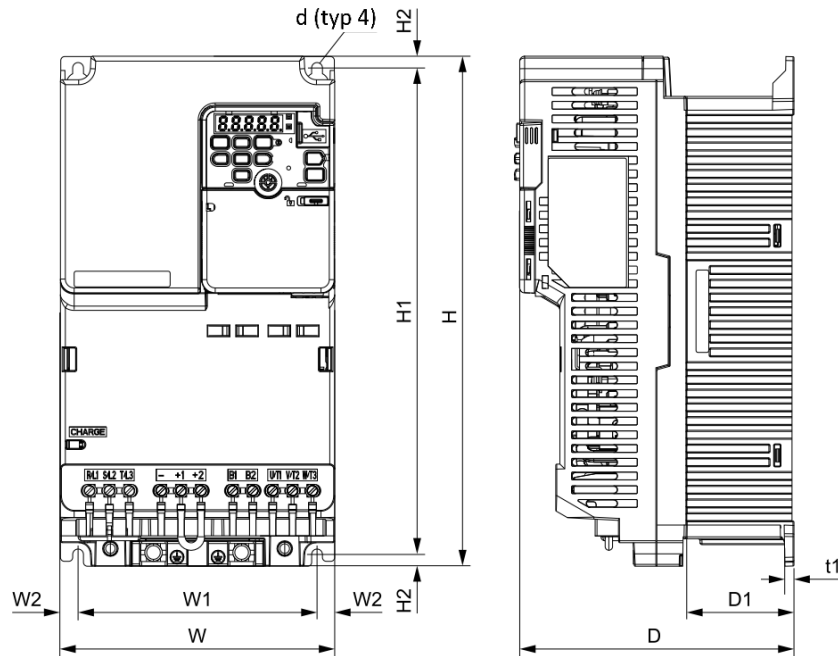

Table 7: GA500 Diagram 3

Model	W	H	H*	W1	W2	H1	H2	D	D1	t1	d
DR-240007-3B	5.51 [140]	10.24 [260]	11.79 [299.5]	4.80 [122]	0.35 [9]	9.75 [248]	0.24 [6]	5.51 [140]	2.17 [55]	0.20 [5]	#10 (M5)
DR-240010-3B	5.51 [140]	10.24 [260]	11.79 [299.5]	4.80 [122]	0.35 [9]	9.75 [248]	0.24 [6]	5.51 [140]	2.17 [55]	0.20 [5]	#10 (M5)
DR-240020-3B	7.09 [180]	11.81 [300]	13.44 [341.5]	6.30 [160]	0.39 [10]	11.18 [284]	0.31 [8]	5.63 [143]	2.17 [55]	0.20 [5]	#10 (M5)
DR-240025-3B	8.66 [220]	13.78 [350]	15.93 [404.5]	7.56 [192]	0.55 [14]	13.23 [336]	0.28 [7]	7.36 [187]	3.07 [78]	0.20 [5]	#10 (M5)
DR-240030-3B	8.66 [220]	13.78 [350]	15.93 [404.5]	7.56 [192]	0.55 [14]	13.23 [336]	0.28 [7]	7.36 [187]	3.07 [78]	0.20 [5]	#10 (M5)
DR-480010-3B	5.51 [140]	10.24 [260]	11.79 [299.5]	4.80 [122]	0.35 [9]	9.76 [248]	0.24 [6]	5.51 [140]	2.17 [55]	0.20 [5]	#10 (M5)
DR-480015-3B	5.51 [140]	10.24 [260]	11.79 [299.5]	4.80 [122]	0.35 [9]	9.76 [248]	0.24 [6]	5.51 [140]	2.17 [55]	0.20 [5]	#10 (M5)
DR-480020-3B	7.09 [180]	11.81 [300]	13.44 [341.5]	6.30 [160]	0.39 [10]	11.18 [284]	0.31 [8]	5.63 [143]	2.17 [55]	0.20 [5]	#10 (M5)
DR-480025-3B	7.09 [180]	11.81 [300]	13.44 [341.5]	6.30 [160]	0.39 [10]	11.18 [284]	0.31 [8]	5.63 [143]	2.17 [55]	0.20 [5]	#10 (M5)
DR-480030-3B	7.48 [190]	13.78 [350]	15.93 [404.5]	6.30 [160]	0.59 [15]	13.23 [336]	0.28 [7]	8.03 [204]	3.70 [94]	0.20 [5]	1/4 (M6)
DR-480040-3B	7.48 [190]	13.78 [350]	15.93 [404.5]	6.30 [160]	0.59 [15]	13.23 [336]	0.28 [7]	8.03 [204]	3.70 [94]	0.20 [5]	1/4 (M6)

* Total height of the VFD if installing the NEMA 1 kit (not shown)

Dimensions (continued)

Dimensions in inches [mm]

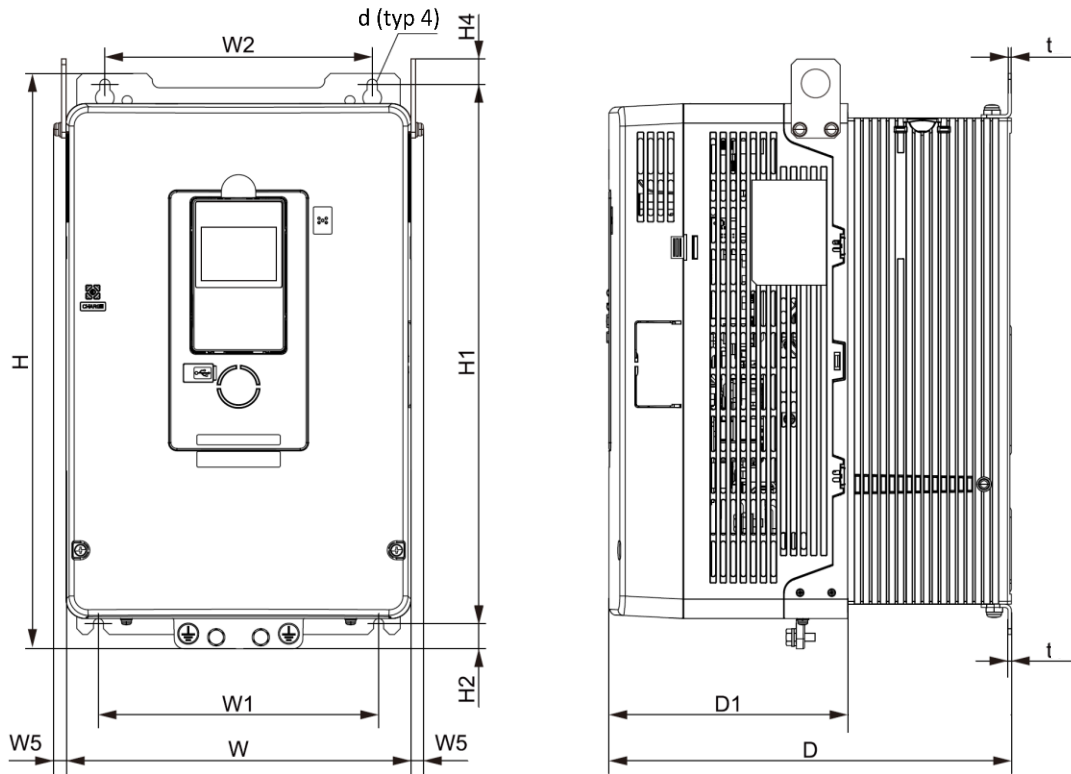

Table 8: GA800 Diagram 1

Model	W	H	W*	H*	W1	W2	W5	H1	H2	H4	t	D	D1	d
DR-240040-3C	9.45 [240]	15.75 [400]	9.61 [244]	19.69 [500]	7.68 [195]	7.32 [186]	0.47 [12]	14.76 [375]	0.69 [17.5]	0.69 [17.5]	0.09 [2.3]	11.02 [280]	6.54 [166]	1/4 (M6)
DR-480050-3C	9.45 [240]	15.75 [400]	9.61 [244]	19.69 [500]	7.68 [195]	7.32 [186]	0.47 [12]	14.76 [375]	0.69 [17.5]	0.69 [17.5]	0.09 [2.3]	11.02 [280]	6.54 [166]	1/4 (M6)

* Total height/width of the VFD if installing the NEMA 1 kit (not shown)

Dimensions (continued)

Dimensions in inches [mm]

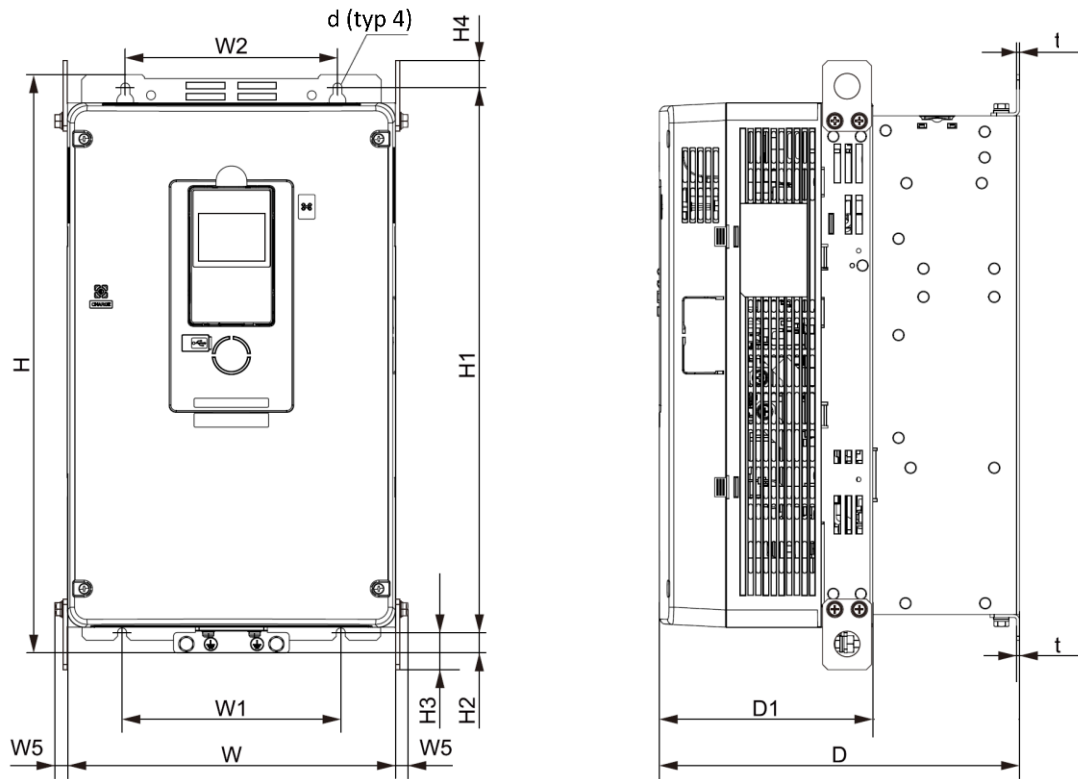

Table 9: GA800 Diagram 2

Model	W	H	W*	H*	W1	W2	W5	H1	H2	H3	H4	t	D	D1	d
DR-240050-3C	10.04 [255]	17.72 [450]	10.20 [259]	22.83 [580]	6.69 [170]	6.50 [165]	0.47 [12]	16.69 (424)	0.63 [16]	1.14 [29]	0.83 [21]	0.09 [2.3]	11.02 [280]	6.54 [166]	1/4 (M6)
DR-480060-3C	10.04 [255]	17.72 [450]	10.20 [259]	22.83 [580]	6.69 [170]	6.50 [165]	0.47 [12]	16.69 (424)	0.63 [16]	1.14 [29]	0.83 [21]	0.09 [2.3]	11.02 [280]	6.54 [166]	1/4 (M6)
DR-480075-3C	10.04 [255]	17.72 [450]	10.20 [259]	22.83 [580]	6.69 [170]	6.50 [165]	0.47 [12]	16.69 (424)	0.63 [16]	1.14 [29]	0.83 [21]	0.09 [2.3]	11.02 [280]	6.54 [166]	1/4 (M6)

* Total height/width of the VFD if installing the NEMA 1 kit (not shown)

Dimensions (continued)

Dimensions in inches [mm]

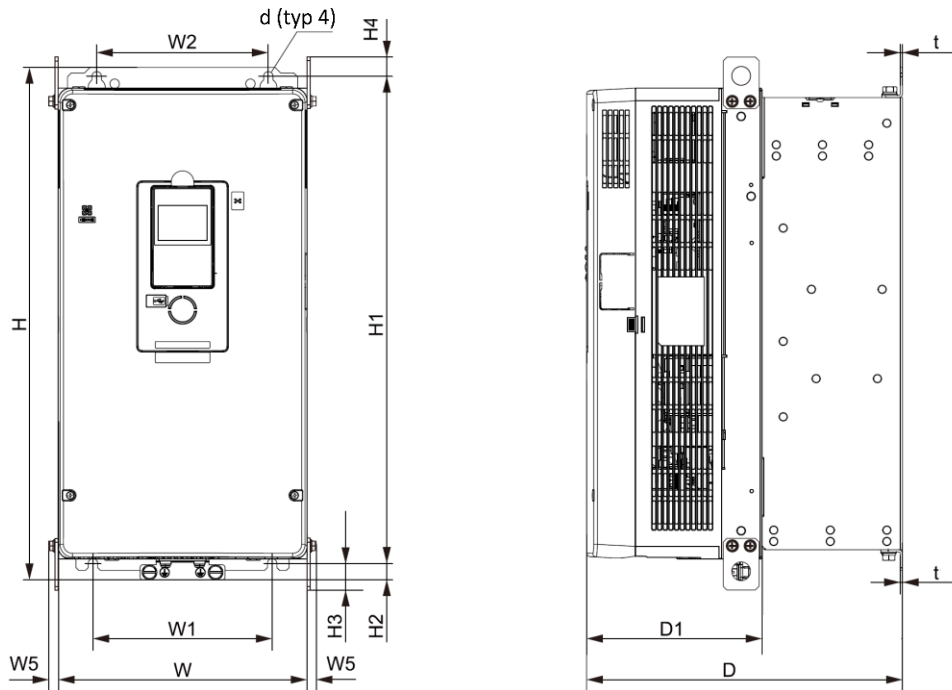

Table 10: GA800 Diagram 3

Model	W	H	W*	H*	W1	W2	W5	H1	H2	H3	H4	t	D	D1	d
DR-240060-3C	10.39 [264]	21.38 [543]	10.55 [268]	27.56 [700]	7.48 [190]	7.17 [182]	0.47 [12]	20.31 [516]	0.69 [18]	1.12 [29]	0.81 [21]	0.09 [2.3]	13.19 [335]	7.32 [186]	5/16 (M8)
DR-240075-3C	10.39 [264]	21.38 [543]	10.55 [268]	30.31 [770]	7.48 [190]	7.17 [182]	0.47 [12]	20.31 [516]	0.69 [18]	1.12 [29]	0.81 [21]	0.09 [2.3]	13.19 [335]	7.32 [186]	5/16 (M8)
DR-480100-3C	10.39 [264]	21.38 [543]	10.55 [268]	27.56 [700]	7.48 [190]	7.17 [182]	0.47 [12]	20.31 [516]	0.69 [18]	1.12 [29]	0.81 [21]	0.09 [2.3]	13.19 [335]	7.32 [186]	5/16 (M8)
DR-480125-3C	10.39 [264]	21.38 [543]	10.55 [268]	27.56 [700]	7.48 [190]	7.17 [182]	0.47 [12]	20.31 [516]	0.69 [18]	1.12 [29]	0.81 [21]	0.09 [2.3]	13.19 [335]	7.32 [186]	5/16 (M8)

* Total height/width of the VFD if installing the NEMA 1 kit (not shown)

Dimensions (continued)

Dimensions in inches [mm]

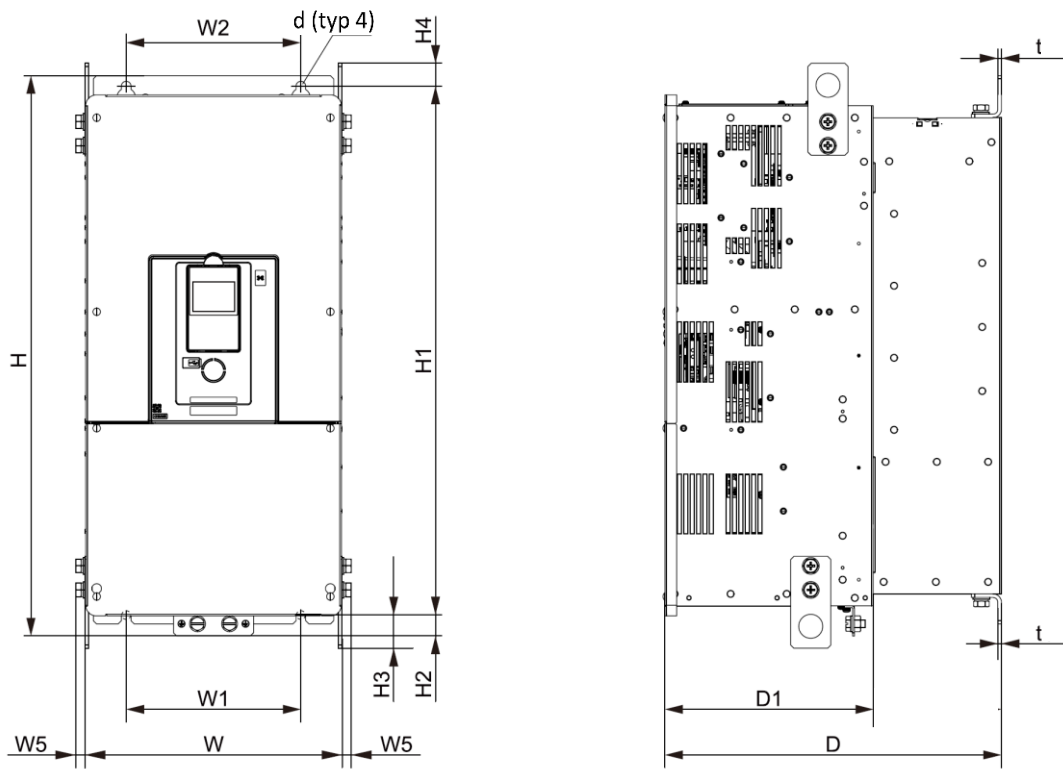

Table 11: GA800 Diagram 4

Model	W	H	W*	H*	W1	W2	W5	H1	H2	H3	H4	t	D	D1	d
DR-240100-3C	12.28 [312]	27.56 [700]	12.44 [316]	36.02 [915]	8.58 [218]	8.58 [218]	0.71 [18]	25.94 [659]	1.10 [28]	1.71 [43.5]	1.12 [28.5]	0.18 [4.5]	16.54 [420]	10.24 [260]	3/8 (M10)
DR-480150-3C	12.28 [312]	27.56 [700]	12.44 [316]	36.02 [915]	8.58 [218]	8.58 [218]	0.71 [18]	25.94 [659]	1.10 [28]	1.71 [43.5]	1.12 [28.5]	0.18 [4.5]	16.54 [420]	10.24 [260]	3/8 (M10)
DR-480200-3C	12.28 [312]	27.56 [700]	12.44 [316]	36.02 [915]	8.58 [218]	8.58 [218]	0.71 [18]	25.94 [659]	1.10 [28]	1.71 [43.5]	1.12 [28.5]	0.18 [4.5]	16.54 [420]	10.24 [260]	3/8 (M10)

* Total height/width of the VFD if installing the NEMA 1 kit (not shown)

Dimensions (continued)

Dimensions in inches

Line Reactors / Load Reactors

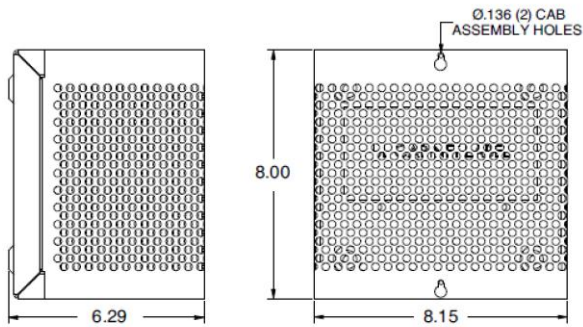

UNITS: INCHES

Reactor Enclosure #1

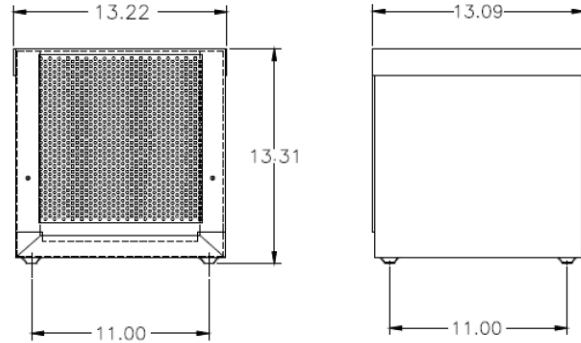

UNITS: INCHES

Reactor Enclosure #2

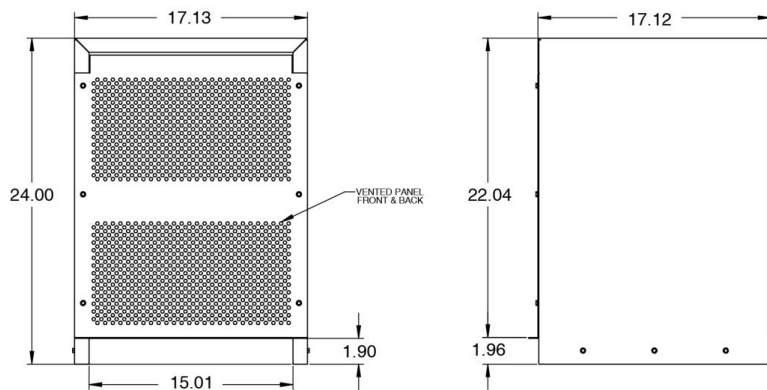

UNITS: INCHES

Reactor Enclosure #3

Dimensions (continued)

Dimensions in inches

Line Reactors / Load Reactors**Table 12: 240V Single Phase Line Reactors**

Line Reactor Part Number	Reactor Enclosure #	Est. Weight lb [kg]
DRLR-2024-1-F16-1	1	2 [0.9]
DRLR-2024-1-F14-1	1	2 [0.9]
DRLR-2024-1-F34-1	1	2 [0.9]
DRLR-2024-1-1-1	1	3 [1.4]
DRLR-2024-1-2-1	2	4 [1.8]
DRLR-2024-1-3-1	2	4 [1.8]
DRLR-2024-1-5-1	2	5 [2.3]

Table 13: 240V Three Phase Line Reactors

Line Reactor Part Number	Reactor Enclosure #	Est. Weight lb [kg]
DRLR-2024-3-F16-1	1	2 [0.9]
DRLR-2024-3-F14-1	1	2 [0.9]
DRLR-2024-3-F34-1	1	2 [0.9]
DRLR-2024-3-1-1	1	2 [0.9]
DRLR-2024-3-2-1	1	2 [0.9]
DRLR-2024-3-3-1	1	3 [1.4]
DRLR-2024-3-5-1	1	3 [1.4]
DRLR-2024-3-7.5-1	2	4 [1.8]
DRLR-2024-3-10-1	2	5 [2.3]
DRLR-2024-3-15-1	2	10 [4.5]
DRLR-2024-3-20-1	2	18 [8.2]
DRLR-2024-3-25-1	2	18 [8.2]
DRLR-2024-3-30-1	2	19 [8.6]
DRLR-2024-3-40-1	2	22 [10]
DRLR-2024-3-50-1	2	26 [11.8]
DRLR-2024-3-60-1	2	34 [15.4]
DRLR-2024-3-75-1	3	34 [15.4]
DRLR-2024-3-100-1	3	35 [15.9]

Dimensions (continued)

Dimensions in inches

Line Reactors / Load Reactors

Table 14: 480V Three Phase Line Reactors

Line Reactor Part Number	Reactor Enclosure #	Est. Weight lb [kg]
DRLR-3848-3-F12-1	1	2 [0.9]
DRLR-3848-3-1-1	1	2 [0.9]
DRLR-3848-3-2-1	1	2 [0.9]
DRLR-3848-3-3-1	1	2 [0.9]
DRLR-3848-3-5-1	1	3 [1.4]
DRLR-3848-3-7.5-1	1	4 [1.8]
DRLR-3848-3-10-1	1	4 [1.8]
DRLR-3848-3-15-1	2	7 [3.2]
DRLR-3848-3-20-1	2	10 [4.5]
DRLR-3848-3-25-1	2	10 [4.5]
DRLR-3848-3-30-1	2	13 [5.9]
DRLR-3848-3-40-1	2	17 [7.7]
DRLR-3848-3-50-1	2	22 [10]
DRLR-3848-3-60-1	2	26 [11.8]
DRLR-3848-3-75-1	2	28 [12.7]
DRLR-3848-3-100-1	2	37 [16.8]
DRLR-3848-3-125-1	2	40 [18.1]
DRLR-3848-3-150-1	3	49 [22.2]
DRLR-3848-3-200-1	3	55 [24.9]

Table 15: 240V Single Phase Load Reactors

Line Reactor Part Number	Reactor Enclosure #	Est. Weight lb [kg]
DRMR-2024-1-F16-1	1	3 [1.4]
DRMR-2024-1-F14-1	1	3 [1.4]
DRMR-2024-1-F34-1	1	4 [1.8]
DRMR-2024-1-1-1	1	7 [3.2]
DRMR-2024-1-2-1	1	9 [4.1]
DRMR-2024-1-3-1	1	9 [4.1]
DRMR-2024-1-5-1	1	9 [4.1]

Dimensions (continued)

Dimensions in inches

Line Reactors / Load Reactors**Table 16: 240V Three Phase Load Reactors**

Line Reactor Part Number	Reactor Enclosure #	Est. Weight lb [kg]
DRMR-2024-3-F16-1	1	3 [1.4]
DRMR-2024-3-F14-1	1	3 [1.4]
DRMR-2024-3-F34-1	1	4 [1.8]
DRMR-2024-3-1-1	1	7 [3.2]
DRMR-2024-3-2-1	1	7 [3.2]
DRMR-2024-3-3-1	1	9 [4.1]
DRMR-2024-3-5-1	1	9 [4.1]
DRMR-2024-3-7.5-1	2	11 [5]
DRMR-2024-3-10-1	2	14 [6.4]
DRMR-2024-3-15-1	2	22 [10]
DRMR-2024-3-20-1	2	24 [10.9]
DRMR-2024-3-25-1	2	25 [11.3]
DRMR-2024-3-30-1	2	29 [13.2]
DRMR-2024-3-40-1	2	29 [13.2]
DRMR-2024-3-50-1	2	29 [13.2]
DRMR-2024-3-60-1	2	41 [18.6]
DRMR-2024-3-75-1	2	38 [17.2]
DRMR-2024-3-100-1	2	47 [21.3]

Table 17: 480V Three Phase Load Reactors

Line Reactor Part Number	Reactor Enclosure #	Est. Weight lb [kg]
DRMR-3848-3-F12-1	1	3 [1.4]
DRMR-3848-3-1-1	1	4 [1.8]
DRMR-3848-3-2-1	1	4 [1.8]
DRMR-3848-3-3-1	1	11 [5]
DRMR-3848-3-5-1	1	8 [3.6]
DRMR-3848-3-7.5-1	1	10 [4.5]
DRMR-3848-3-10-1	1	12 [5.4]
DRMR-3848-3-15-1	2	14 [6.4]
DRMR-3848-3-20-1	2	16 [7.3]
DRMR-3848-3-25-1	2	16 [7.3]
DRMR-3848-3-30-1	2	26 [11.8]
DRMR-3848-3-40-1	2	26 [11.8]
DRMR-3848-3-50-1	2	33 [15]
DRMR-3848-3-60-1	2	33 [15]
DRMR-3848-3-75-1	2	37 [16.8]
DRMR-3848-3-100-1	2	43 [19.5]
DRMR-3848-3-125-1	2	54 [24.5]
DRMR-3848-3-150-1	2	54 [24.5]
DRMR-3848-3-200-1	3	80 [36.3]

Dimensions (continued)

Dimensions in inches [mm]

Braking Resistors

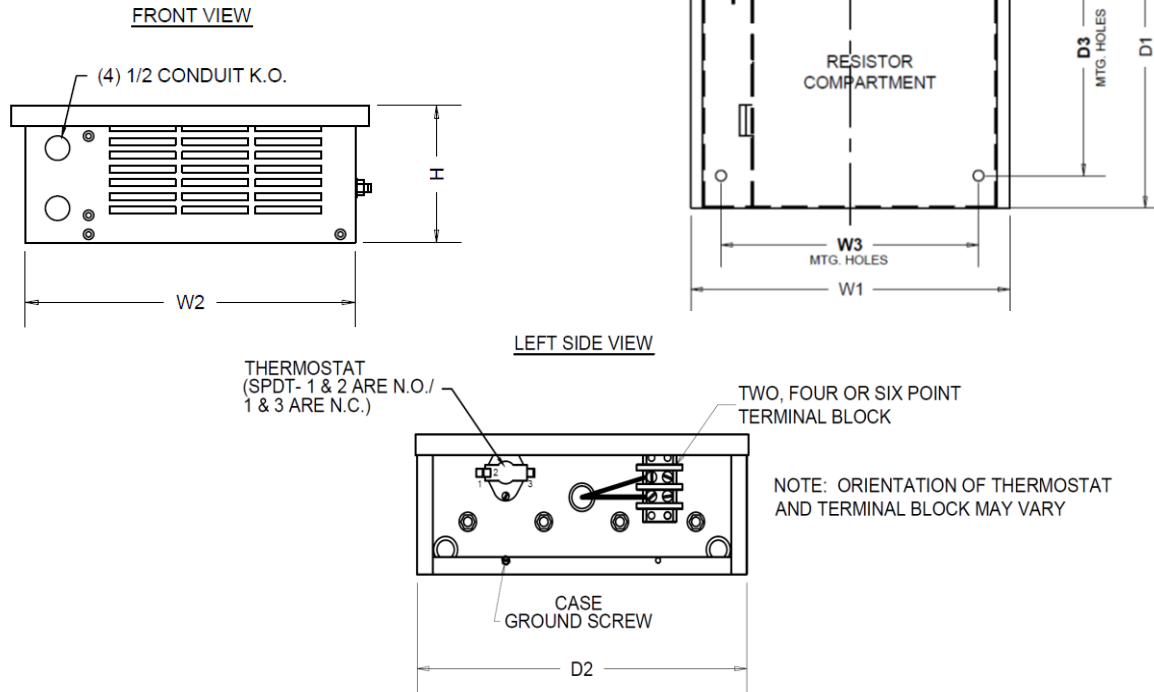

Table 18: Braking Resistors

Enclosure	W1	W2	W3	D1	D2	D3	H
GCE1				5.125 [130.2]	5 [127]	-	5 [127]
GCE2	12.5 [317.5]	12 [304.8]	10.5 [266.7]	7.125 [181.0]	7 [177.8]	4.5 [114.3]	
GCE3				10.125 [257.2]	10 [254]	7.5 [190.5]	
GCE4				13.125 [333.4]	13 [330.2]	10.5 [266.7]	
GCE6				10.125 [257.2]	10 [254]	7.5 [190.5]	
GCE8	19.5 [495.3]	19 [482.6]	17.5 [444.5]	13.125 [333.4]	13 [330.2]	10.5 [266.7]	
GCE9	27 [685.8]	26.5 [673.1]	25 [635]	10.125 [257.2]	10 [254]	7.5 [190.5]	
GCE12				13.125 [333.4]	13 [330.2]	10.5 [266.7]	
GCE15				10.125 [257.2]	16 [406.4]	13.5 [342.9]	
GCE18	28.5 [723.9]	28 [711.2]	26.5 [673.1]	10.125 [257.2]	10 [254]	7.5 [190.5]	
GCE24				13.125 [333.4]	13 [330.2]	10.5 [266.7]	

Dimensions (continued)

Dimensions in inches [mm]

Braking Unit

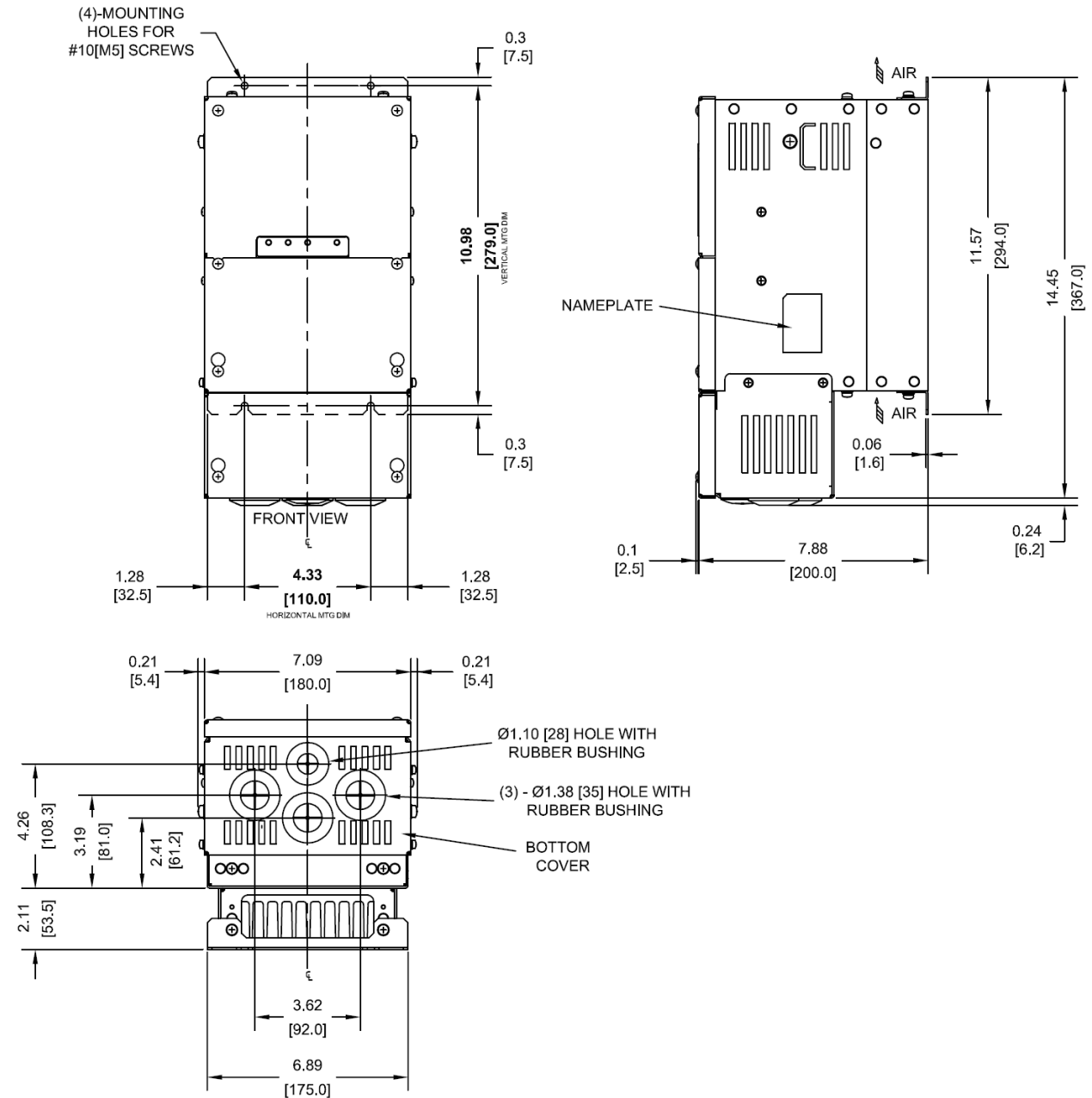

Information in this publication is based on current specifications. The company reserves the right to make changes in specifications and models as design improvements are introduced. Product or company names mentioned herein may be the trademarks of their respective owners. © 2026 SCC Inc.