

TS Series

TS-CE... Combustion Enclosures with LMV5...



Description

TS-CE... series combustion enclosure with Siemens LMV5 linkageless controller sets the standard for combustion control and monitoring technologies. The preprogrammed touchscreen and optional PLC annunciation packages provide monitoring, configuration flexibility, and simple connectivity to an SCC Master Lead/Lag panel for any boiler and burner/boiler installation. The TS-CE... combustion enclosure also provides easy installation.

The TS-CE... combustion control panels with LMVs provide a common centralized center to monitor and retrieve information, resulting in efficient operation of the burner.

All burner flame safeguard and combustion safety control is performed by the advanced Siemens linkageless controller.

Touchscreen options include Modbus TCP/IP communication to a separate master lead/lag panel, or to a third party BMS, as standard with touchscreens. Optional capability to communicate with building management systems is available via Modbus RTU, RS232 or RS485 connections, Johnson Metasys N2, BACnet MS/TP or BACnet IP, Ethernet/IP, LonWorks, Profinet, and Profibus.

Features

TS-CE... combustion enclosure with LMV52 is UL 508 listed and includes the following:

- 6", 10", 12" and 15" touchscreen option
- LMV51 or LMV52 Siemens linkageless control and flame safeguard
- Backlit AZL52 display
- Control for up to six (6) SQM45/48/91 actuators, up to 5 simultaneously
- Programmable logic controller (PLC)
- Steam or hot water boiler control
- Flame supervision and flame strength monitoring
- UV or IR scanners
- Single or dual fuel
- Oil pump control
- Blower motor control
- Atomizing compressor control
- Lead/lag ready with SCC TS... master lead/lag panel
- VSD control
- Blower motor sensor for motor RPM monitoring
- O₂ trim and monitoring, with LMV52 only
- Efficiency calculation with O₂, with LMV52 only
- Thermal shock protection, PT1000 RTD required for steam boilers
- Low fire hold based on temperature setpoint
- Temperature based stepping start
- Time based stepping start
- Combination of temperature and time based stepping start
- FGR low temperature hold
- Shell water temperature monitoring
- External and proven interlocks
- Actuator position display
- LMV5 lockout and fault history
- Stack temperature monitoring
- Burner operation phase display
- Local touchscreen interface with Siemens LMV.../RWF controllers
- Configurable boiler graphics and field tag information
- LMV... static, fuel, lockout, and error history displayed
- Fuel-Air Ratio control curve displayed on touchscreen
- Alarm history for most recent 250 faults/alarms
- Detailed annunciation of LMV... digital inputs and outputs

- Variable Speed Drive information and setup when preprogrammed VFD provided by SCC Inc.
- Remote setpoint, firing rate, and/or enable the LMV... or RWF... via BMS
- Standard or Metric units display
- English or Spanish languages
- Local touchscreen interface with Siemens LMV/RWF controllers, and VFDs.
- Boiler graphics and field tag information are field-configured
- LMV... static, fuel and internal lockout and error history displayed
- Fuel-air ratio control curve displayed
- Alarm history stored for most recent 250 faults/alarms
- Detailed annunciation of LMV... digital inputs and outputs
- Remote setpoint, firing rate and/or enable of the LMV... or RWF... via BMS
- Water level control option and status via RWF55, or PLC
- One or three element feedwater control
- Circulating pump VFD control hot water boilers
- Metric or Standard units displayed
- Clear English or Spanish text for alarms
- Circulating pump/isolation valve control outputs for hydronic boilers (option with expanded annunciator)
- Expanded annunciator options include:
 - Four analog inputs with field configurable label, span and type (0-10V, 2-10V, 0-20mA or 4-20mA), low and high alarm setpoints, with auto or manual reset. Totalization available per minute or per hour.
 - Two analog outputs with field configurable span and type (0-10V, 2-10V, 0- 20mA or 4-20mA); low and high alarm setpoints, with auto or manual reset. Totalization available per minute or per hour.
 - Two dedicated analog outputs for circulating pump VFD control, and water level control, with field configurable span (4-20mA); low and high alarm setpoints, with auto or manual reset.
 - Twelve universal inputs to be field configured for either 1000, or 100 ohm RTDs, or thermocouples type K, or J temperature inputs, analog inputs 4-

- 20mA, with field configurable label, low and high alarm setpoints, with auto or manual reset.
- Two digital outputs with field configurable logic, including on and off delays. Manual or automatic reset.
- Eight field configured monitored value output relays
- First-out annunciation option, including Thirty 120 VAC inputs with field labeling capability
- Eight selectable data logging variables stored in CSV format on USB drive.
- Four selectable variables for trending up to 7 days.
- Economizer temperature monitoring.
- Draft control with SQM5 actuator.
- Connection for two additional RWF55 controllers.
- Screen saver with PV, setpoint, demand, and status
- Standard Modbus TCP/IP to BMS communications
- Additional BMS communication options available
- Email communications and text messaging for up to six (6) recipients include alarms, faults, and screen shots (screen shot viewer via USB)
- Remote monitoring via mobile device (smartphone, tablet, etc.)
- Compatible with SCC Master Panel Lead/Lag system

Application

TS-CE...combustion enclosure panels with LMV5 systems are suited for hot water and steam boilers, with up to 600 in/lb. of actuators torque, for single or dual fuel applications.

Standard Components

- LMV5 linkageless parallel positioning flame safeguard
- LMV5 CANbus power supply transformer
- Power fail relay
- System alarm
- Circuit breaker, 3 Amp, single pole
- Circuit breaker, 10 Amp, single pole
- Non-fused disconnect switch
- Burner ON/OFF switch
- Fuel selector switch
- Safety limits powered, white indicator light
- Safety limits complete, green indicator light
- Pilot burner ON, yellow indicator light
- Gas valve open, blue indicator light
- Oil valve open, yellow indicator light
- Power fail, red illuminated indicator light with reset push button
- Low water, red illuminated indicator light with reset push button
- LMV lockout, red illuminated indicator light with reset push button
- Alarm reset push button
- Alarm horn
- Gray terminals, general
- White terminals, 120 VAC neutral
- Black terminals, 120 VAC hot
- Red terminals, 24 VDC +
- Blue terminals, 24 VDC -
- Orange terminals, 24 VAC
- Yellow terminals, dry contact powered from second source
- Green non-grounding, shield terminals
- Green/yellow PE terminals

Optional Components

- 6", 10", 12" or 15" touchscreen
- Programmable Logic Controller with additional annunciation inputs/outputs
- Additional digital inputs and outputs for various boiler applications such as coil boilers
- Second CANbus power transformer fuse protection with fuses and fuse holder
- LWCO manual, auto reset, or dual function with high water alarm Warrick relays for probe type level control
- Draft control with Siemens SQM5 actuator with type "A" control board only
- Analog inputs/outputs for water Level one or three element PLC feedwater control
- Analog inputs/outputs for circulating pumps steam or hot water PLC VFD control
- Fan air cooling
- Additional RWF... external load or water level controller
- BMS communication options other than Modbus TCP/IP
- Three phase 480 VAC power option includes the following:
 - Main three phase fused disconnect 30Amps/60Amps/100 Amps
 - VSD three phase fuses and fuse holders
 - Blower motor starter for up to 20hp with overload and built in disconnect
 - Oil motor starter for up to 10hp with overload and built in disconnect
 - Compressor motor starter for up to 20hp with overload and built in disconnect
 - 1000 VA circuit control transformer
- Deaerator/Surge control panels (See TS-3000)
- Master lead/lag control panels (See TS-2000)

***Universal inputs:**

There are four universal inputs per input module. Each module must be configured for the same input, either 4-20 mA, Thermocouple type K or J, or RTD 1000 or 100 ohms. If the maximum of three universal modules are included, the first and second modules may each be configured for a different input type, and the third module will automatically be the same as the second universal module.

Specifications without 3-Phase Power

		With Touchscreen	W/out Touchscreen
Electrical characteristics	Main power	120 VAC	120 VAC
	Frequency	60 Hz	60 Hz
	Component power	24 VDC/VAC	120 VAC
	Power consumption	≤ 960 VA	≤ 740 VA
Operating environment	Operating temperature	32 to 122 °F [0 to 50 °C]	-4 to 140 °F [-20 to 60 °C]
	Humidity	Max. 85% with no condensation	Max. 85% with no condensation

Specifications with 3-Phase Power

		With Touchscreen	W/out Touchscreen
Electrical characteristics	Main power	480 VAC	480 VAC
	Frequency	60 Hz	60 Hz
	Current	≤ 72 Amps	≤ 72 Amps
	Component power	24 VDC/VAC	120 VAC
	Power consumption	≤ 35 KVA	≤ 35 KVA
Operating environment	Operating temperature	32 to 122 °F [0 to 50 °C]	-4 to 140 °F [-20 to 60 °C]
	Humidity	Max. 85% with no condensation	Max. 85% with no condensation

Connections

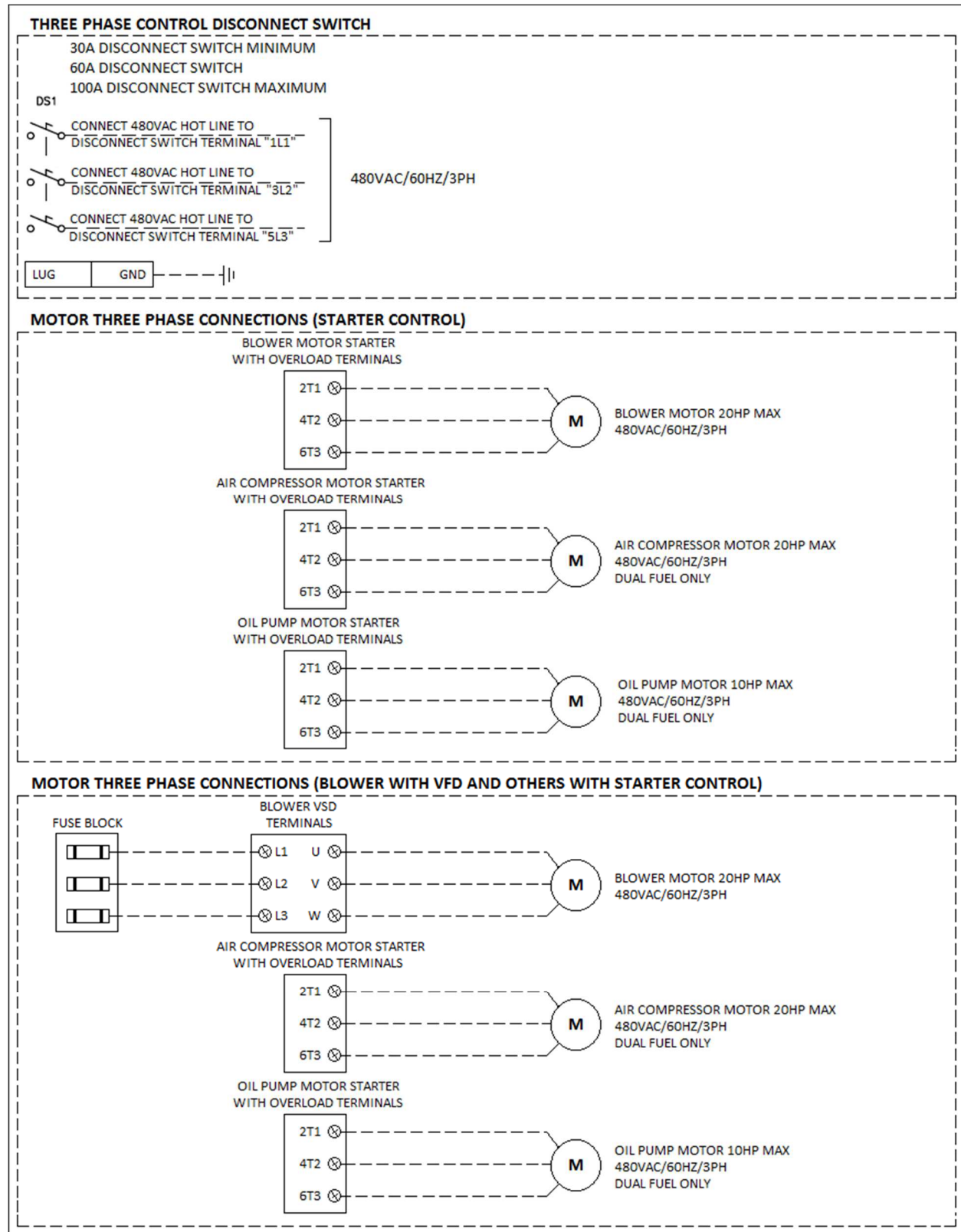

Connections (continued)

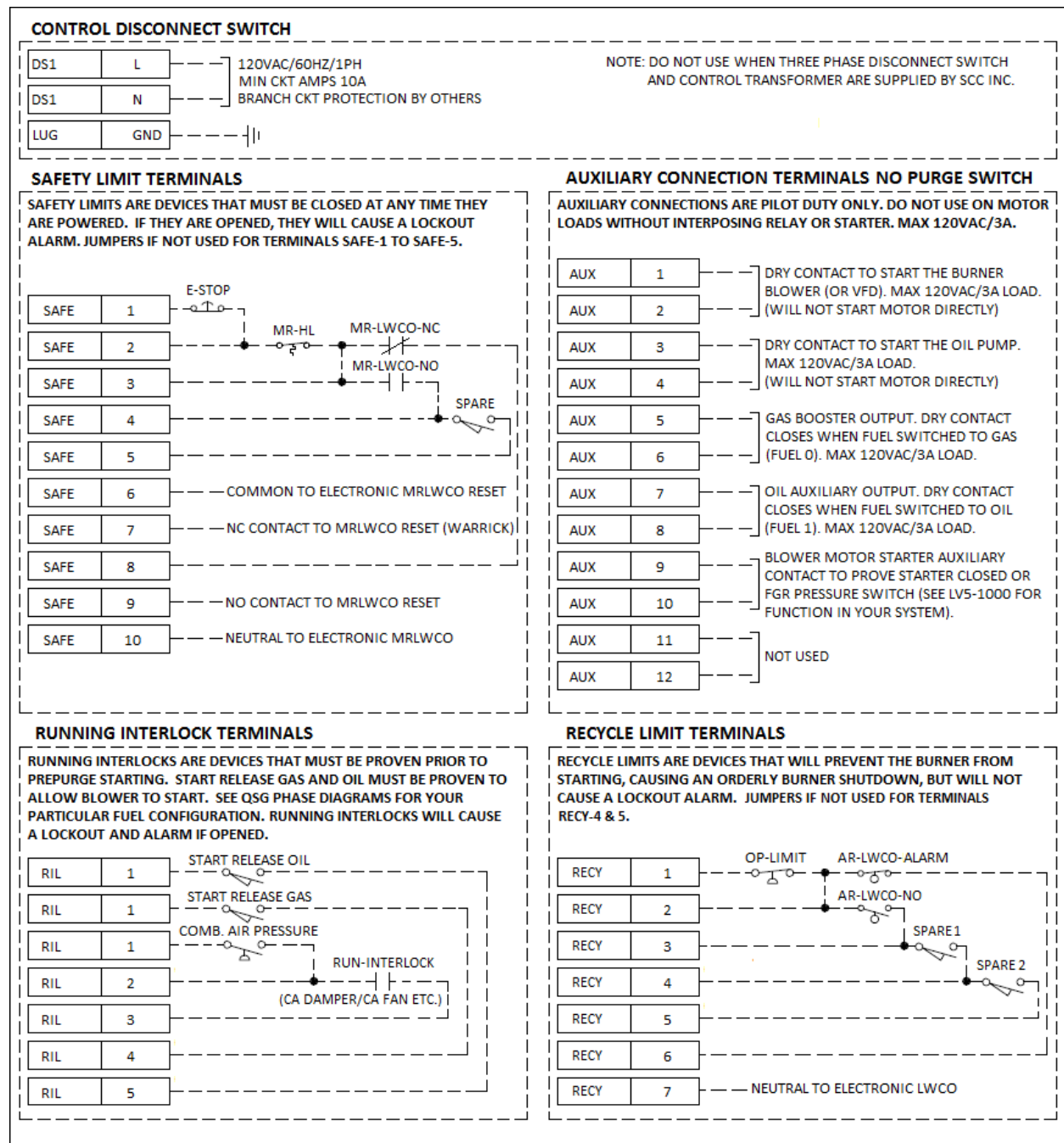

Connections (continued)

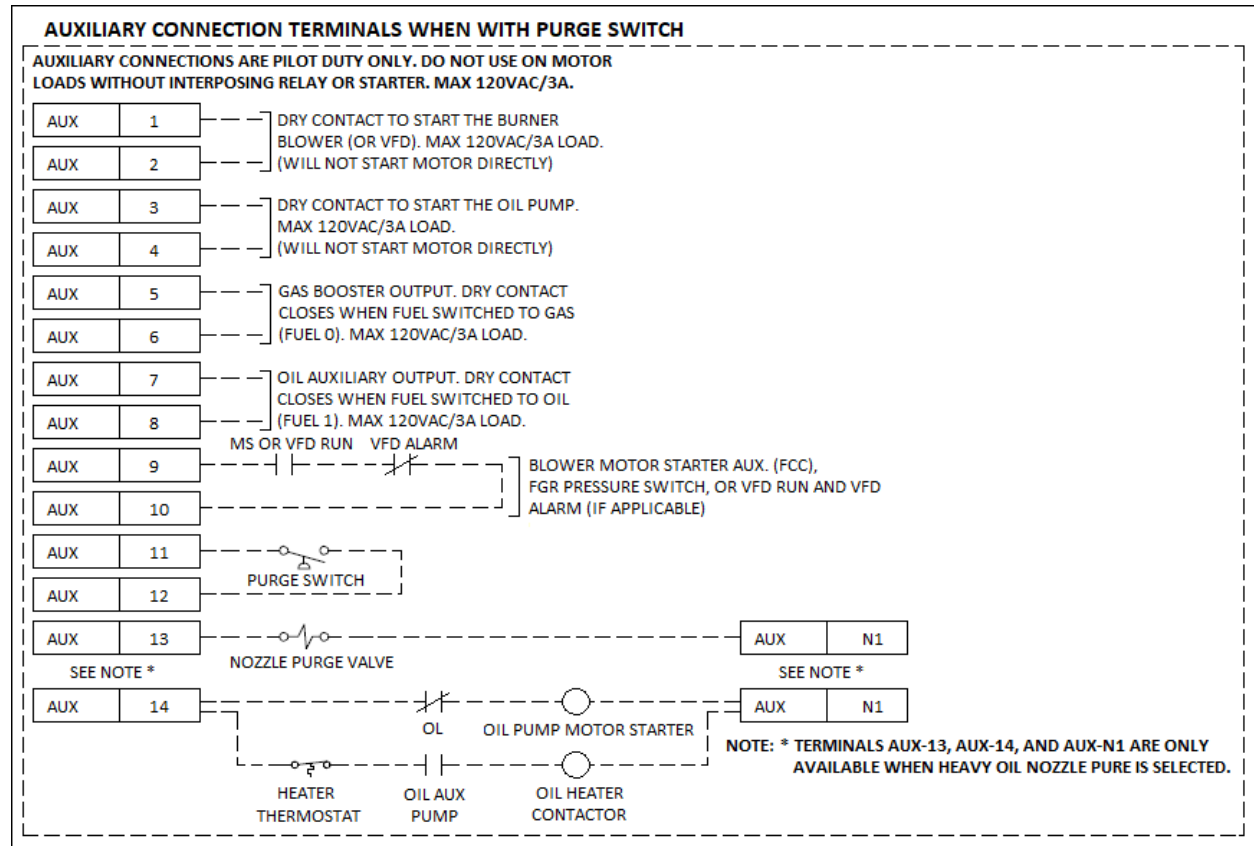

Connections (continued)

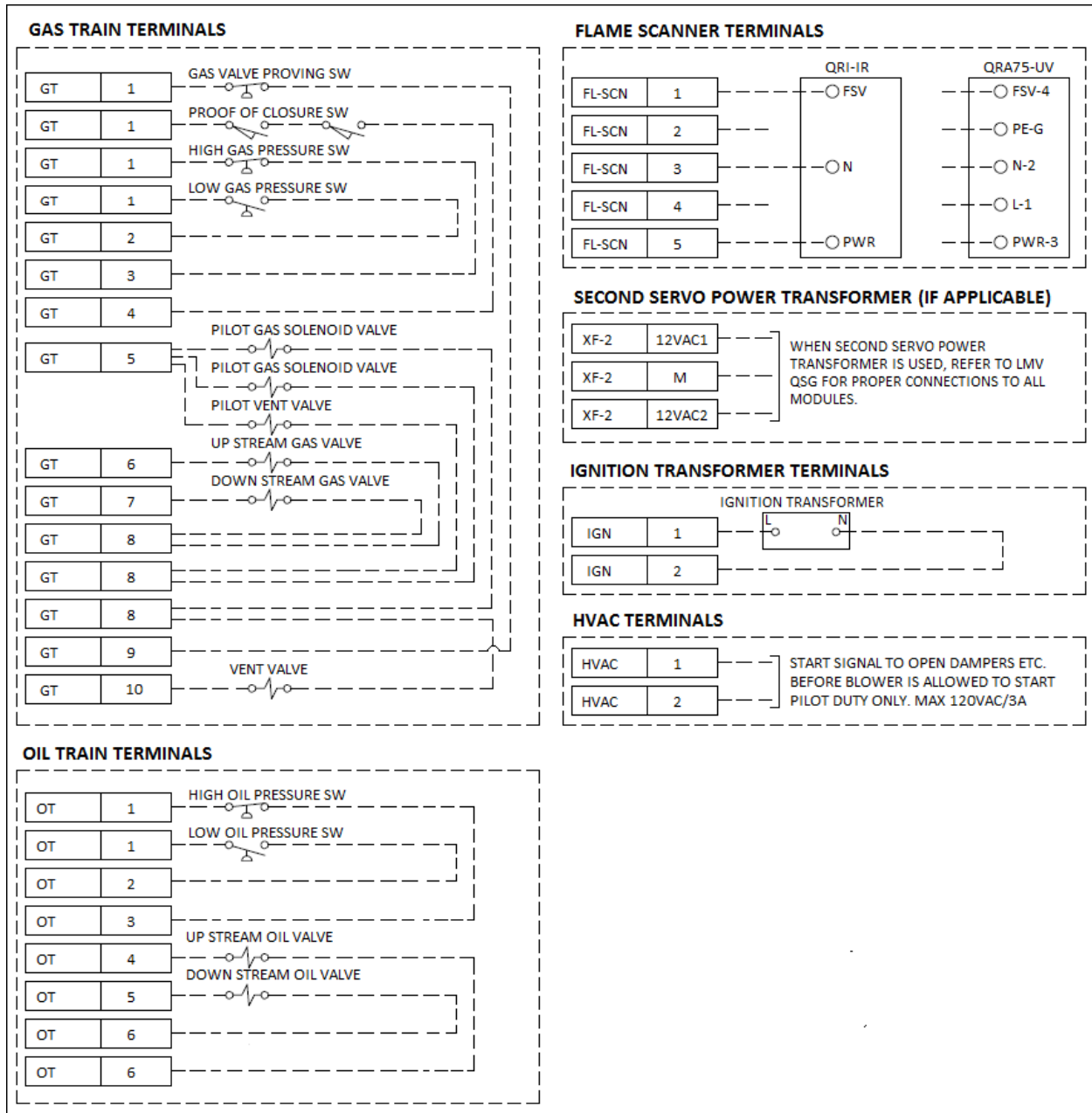

Connections (continued)

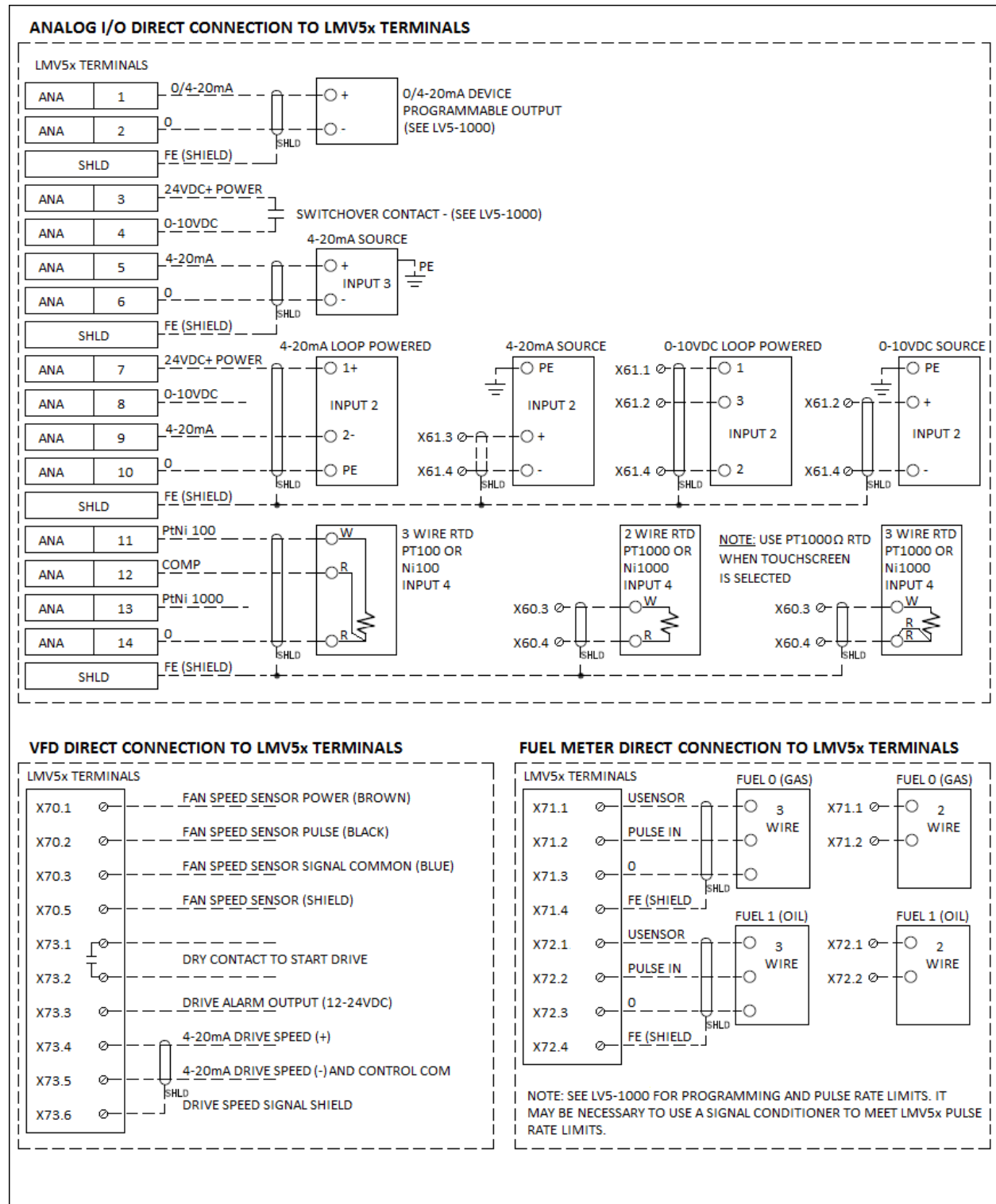

Connections (continued)

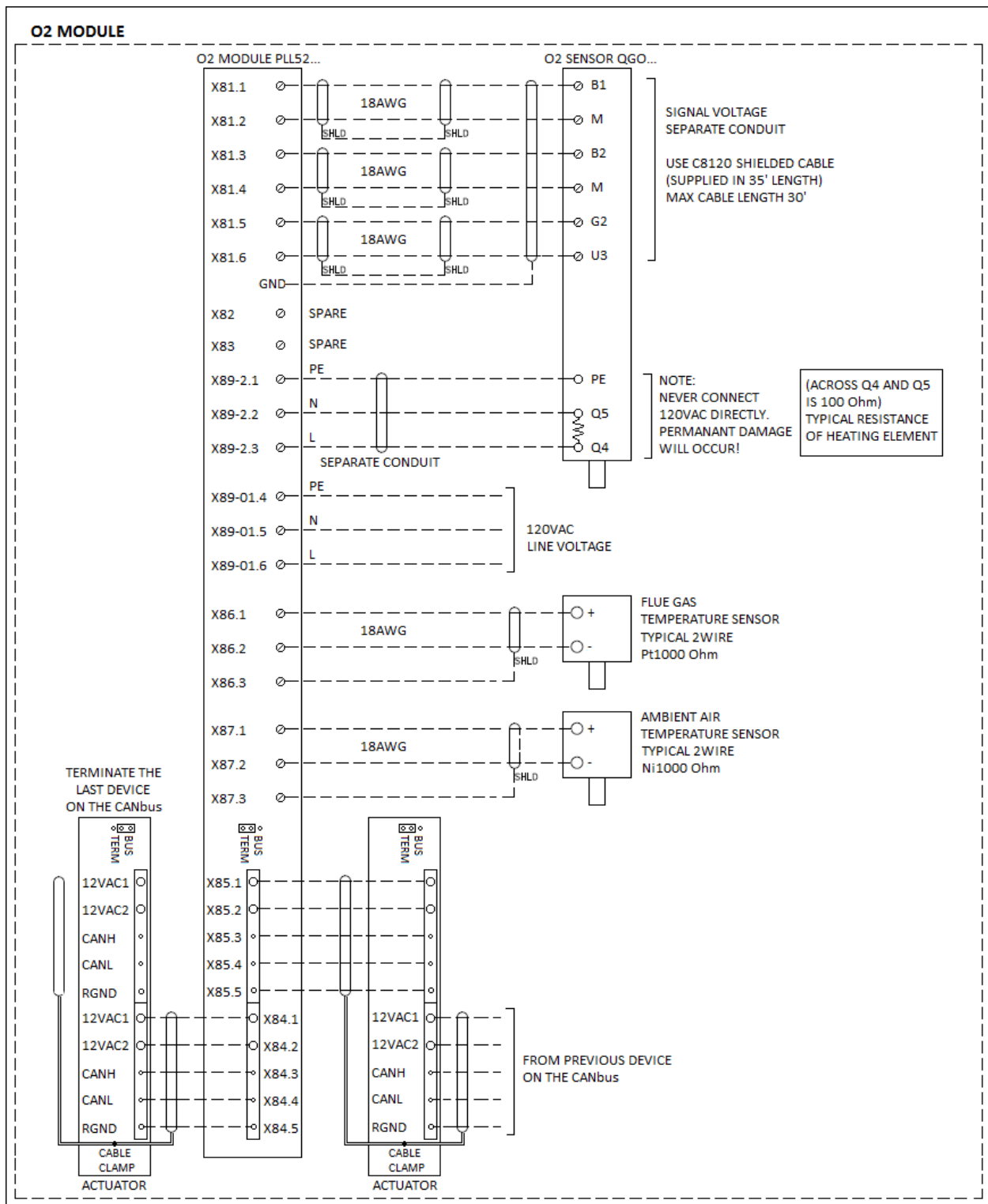

Connections (continued)

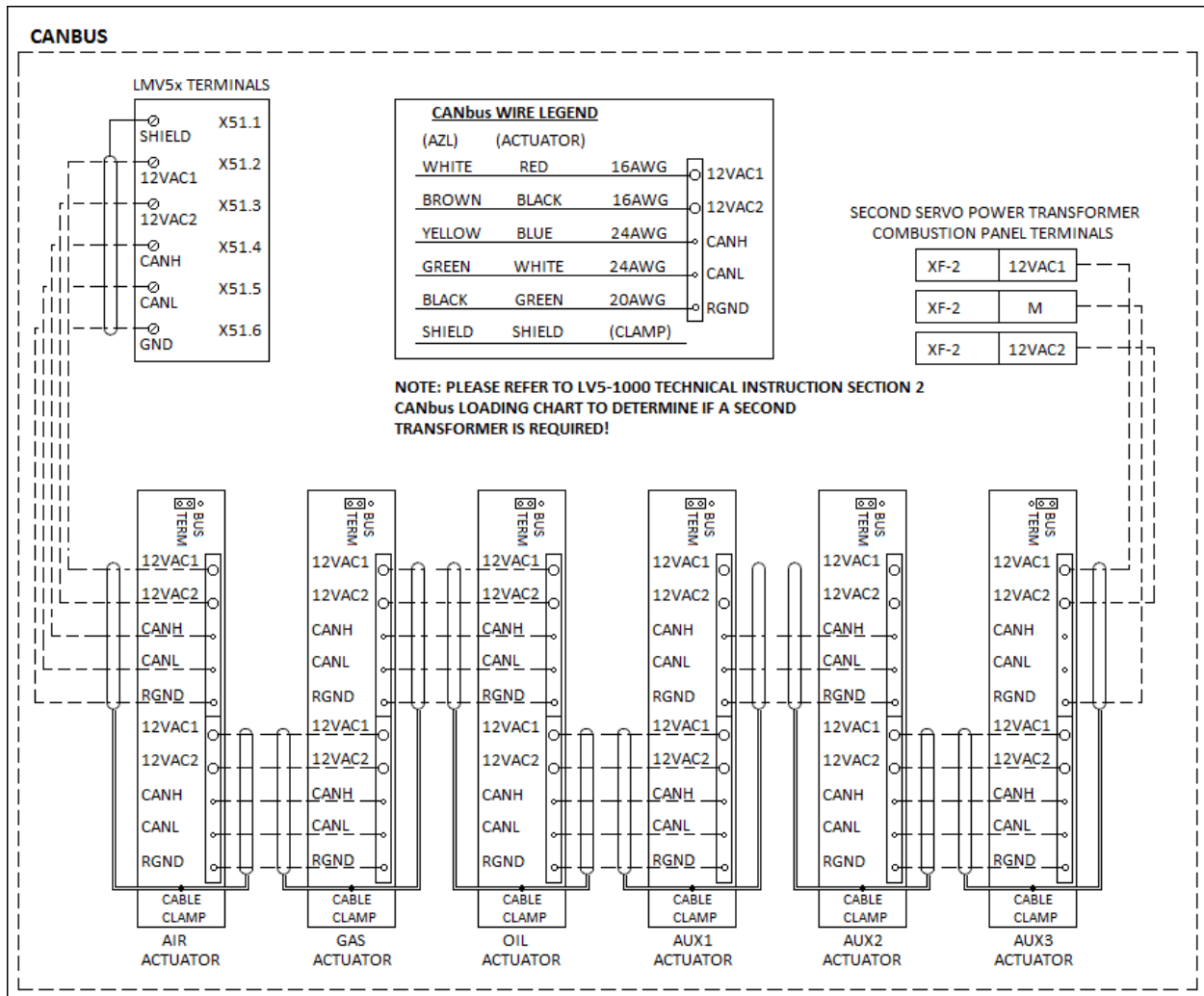

Note: Only 4 actuators may be connected on an LMV51 controller.

Connections (continued)

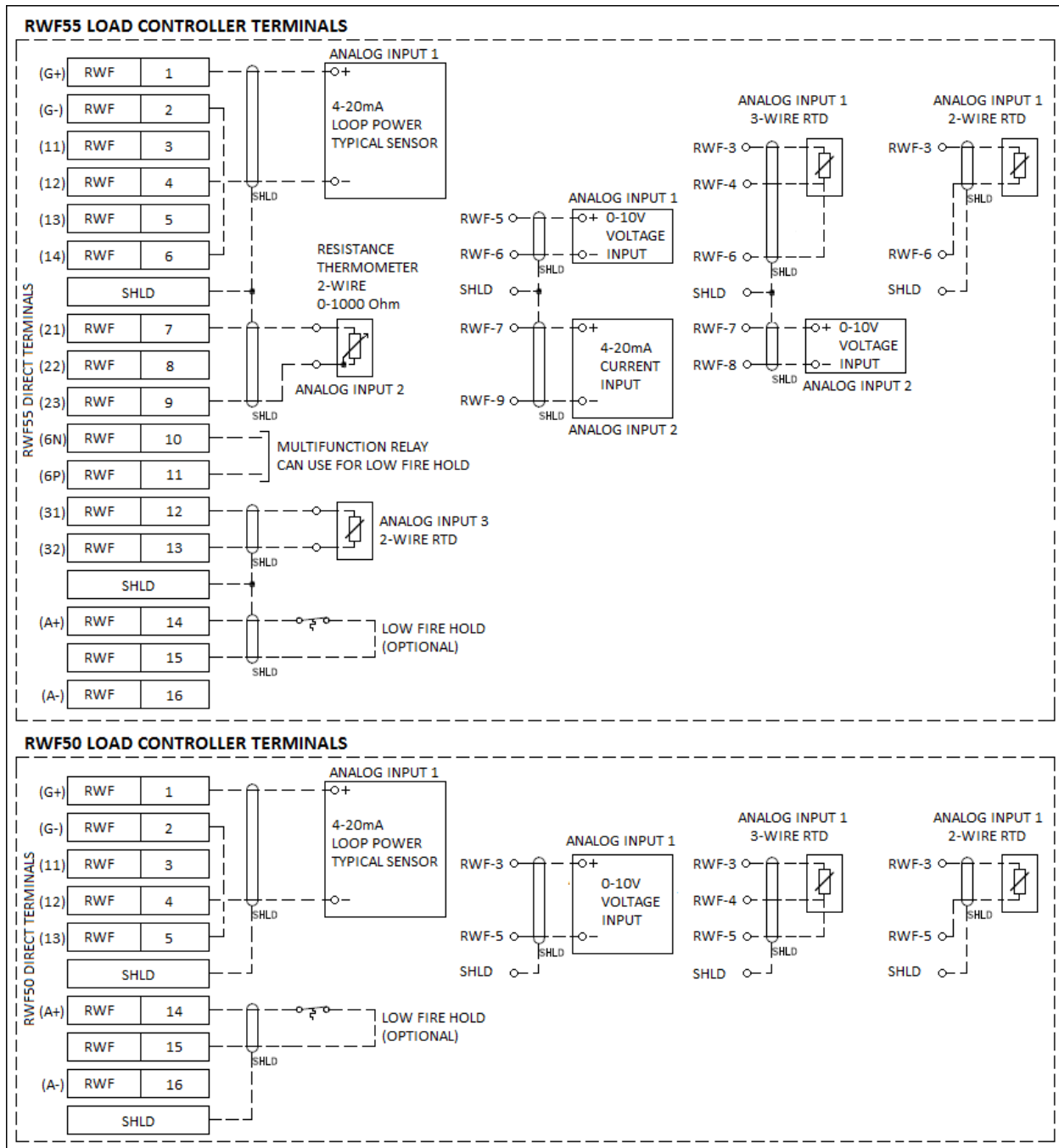

Connections (continued)

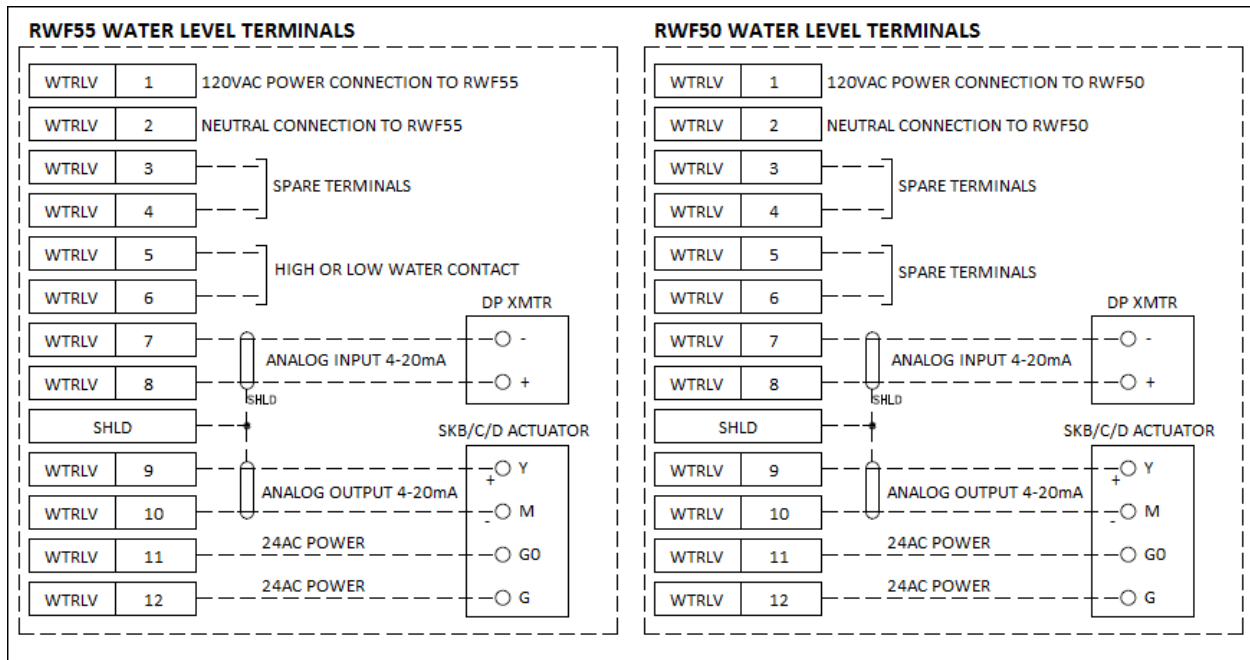

Connections (continued)

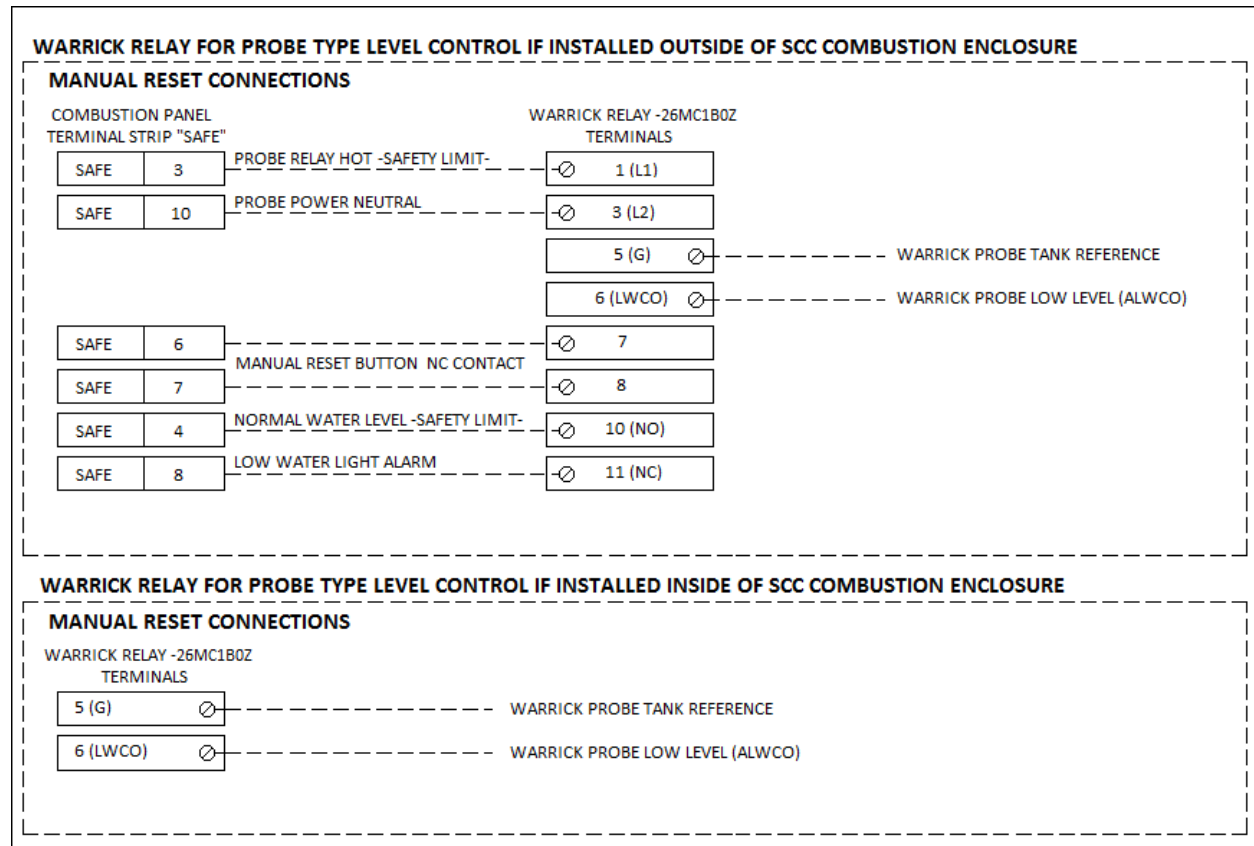

Connections (continued)

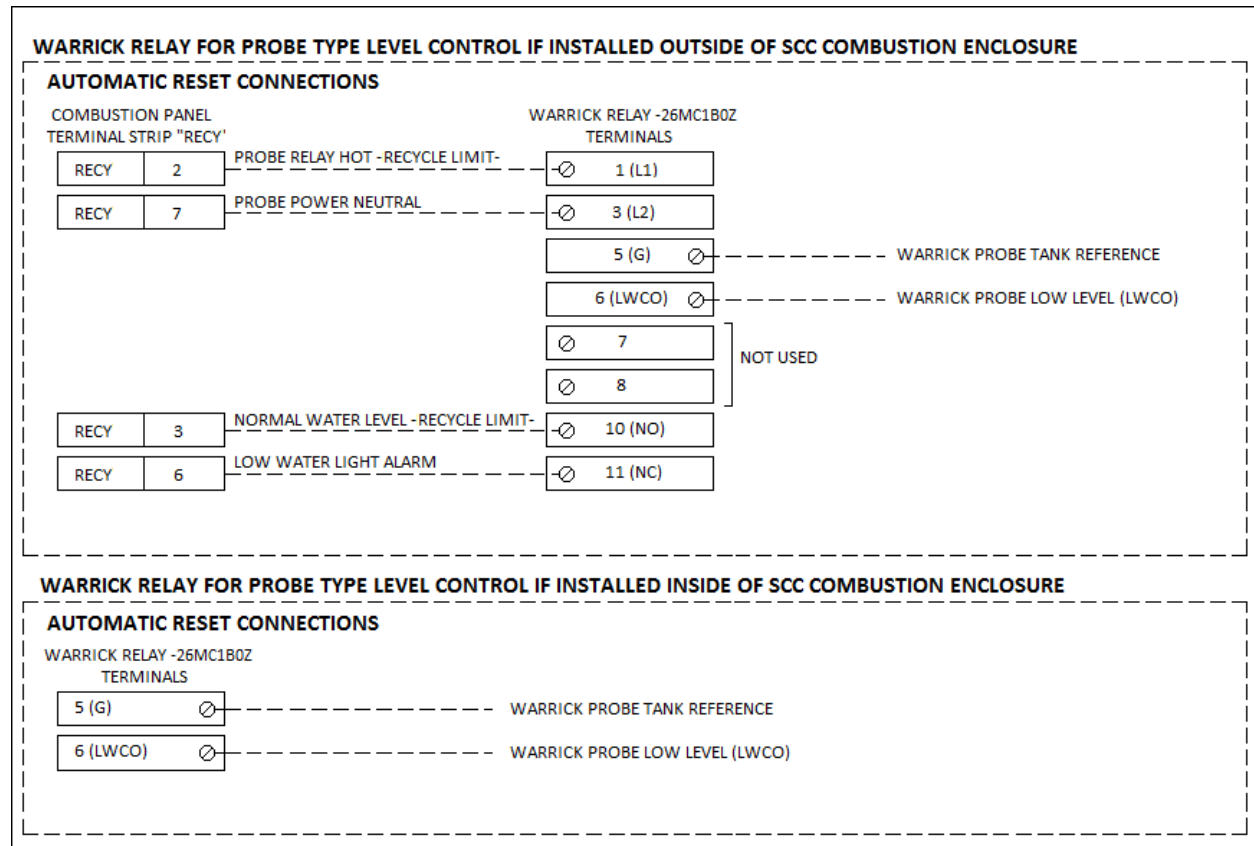

HIGH WATER ALARM

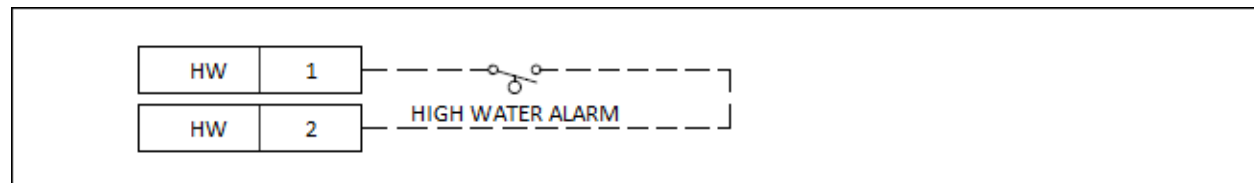

Connections (continued)

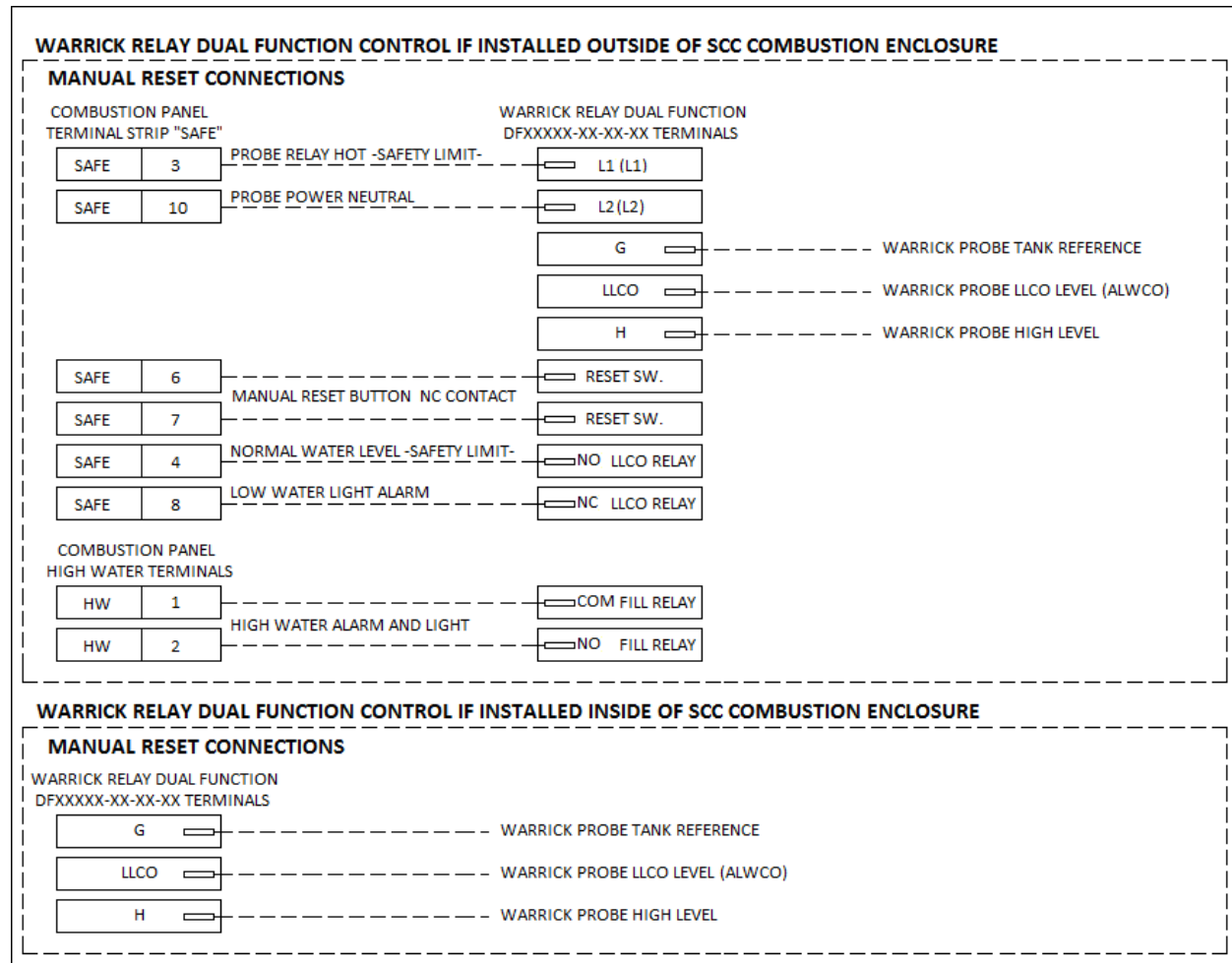

Connections (continued)

Additional RWF55 loop control Modbus connection. Only for kits with annunciation options for up to two connections:

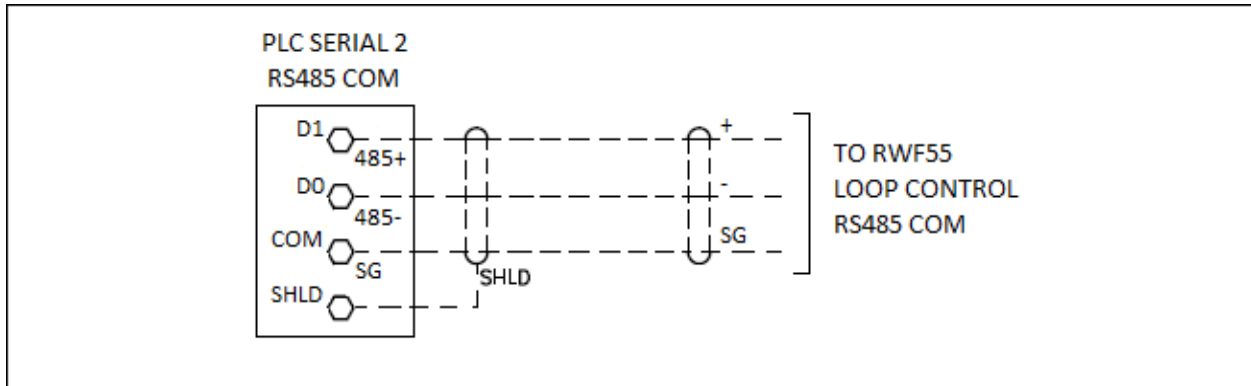

Modbus RS485 serial connection with Yaskawa drive:

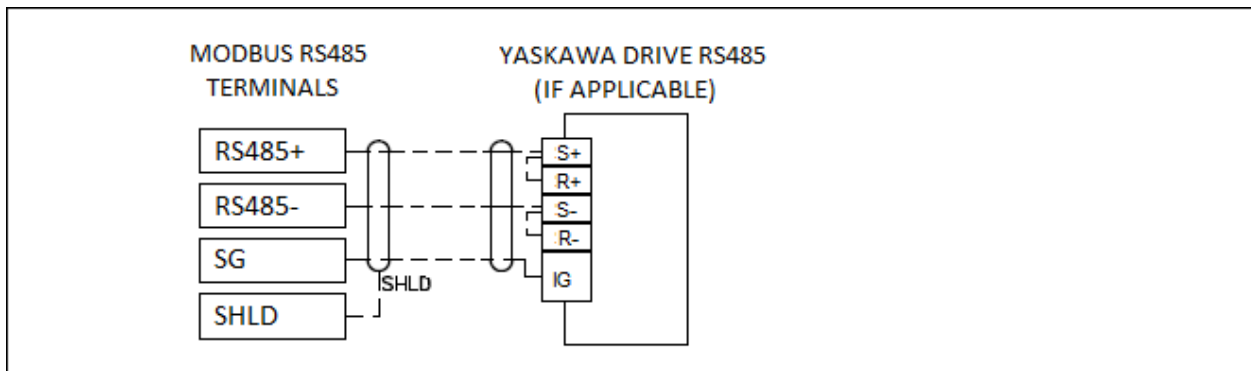

Modbus RS485 serial connection with RWF55 water level and Yaskawa drive:

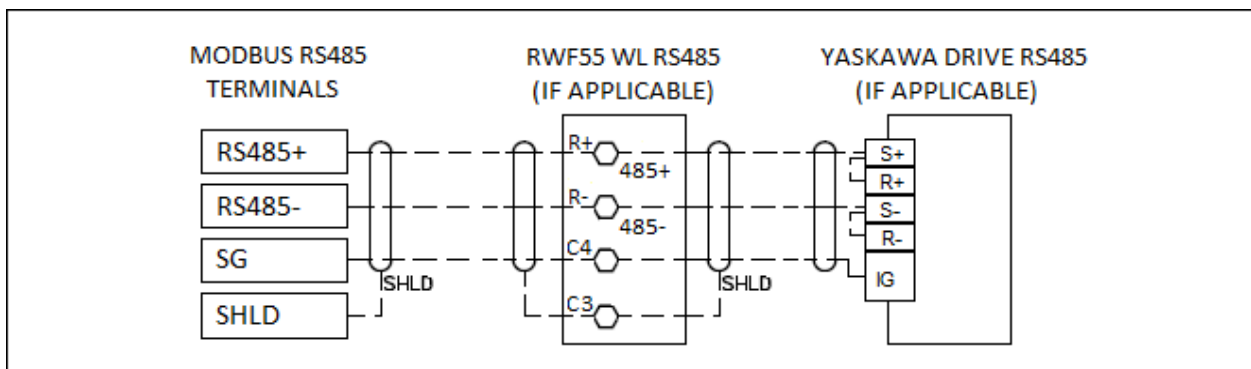

Connections (continued)

Standard annunciation fourteen (14) 120 VAC inputs:

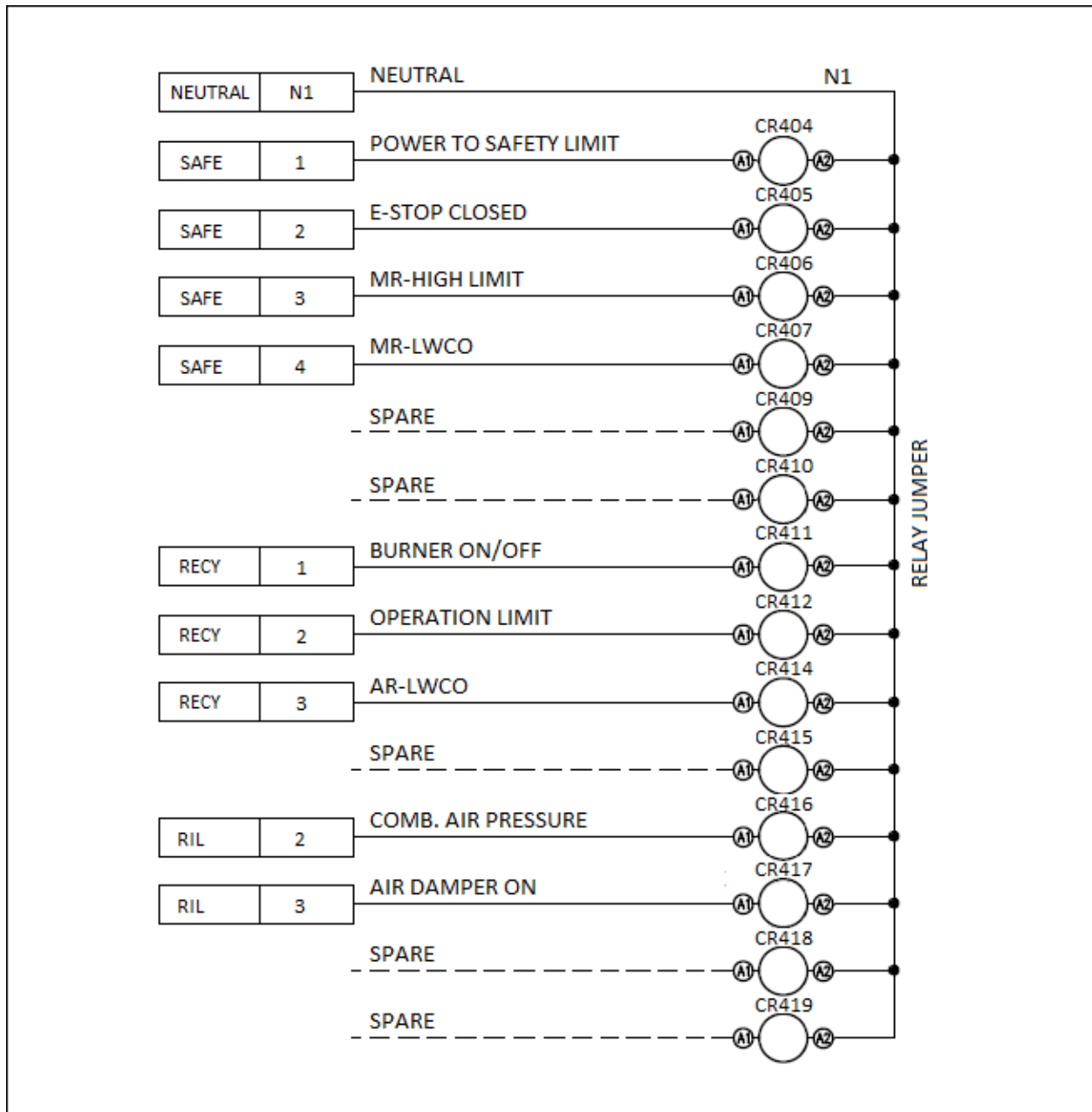

Connections (continued)

Standard annunciation fourteen (14) 120 VAC inputs with draft control:

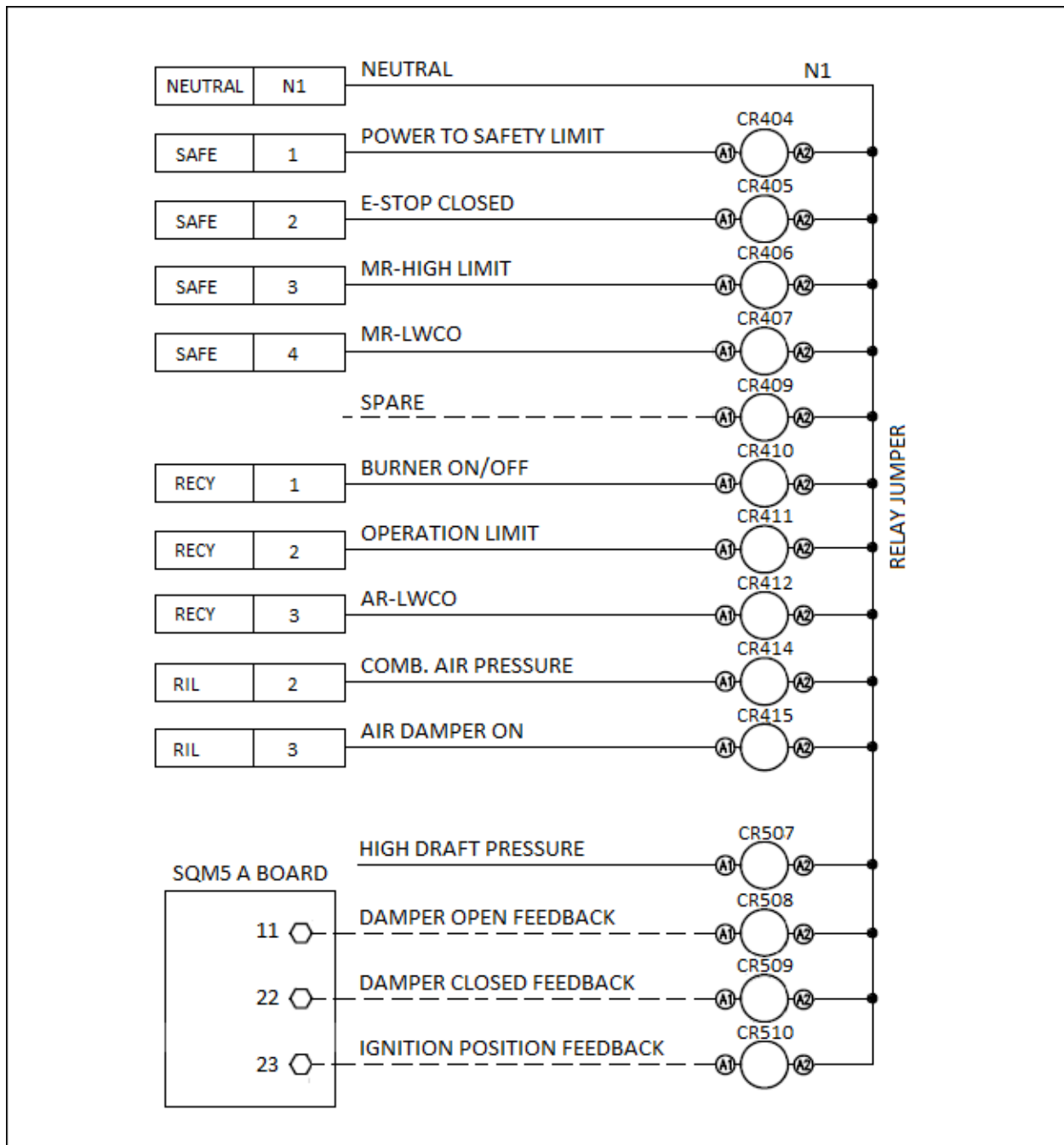

Connections (continued)

Standard annunciation sixteen (16) 120 VAC inputs:

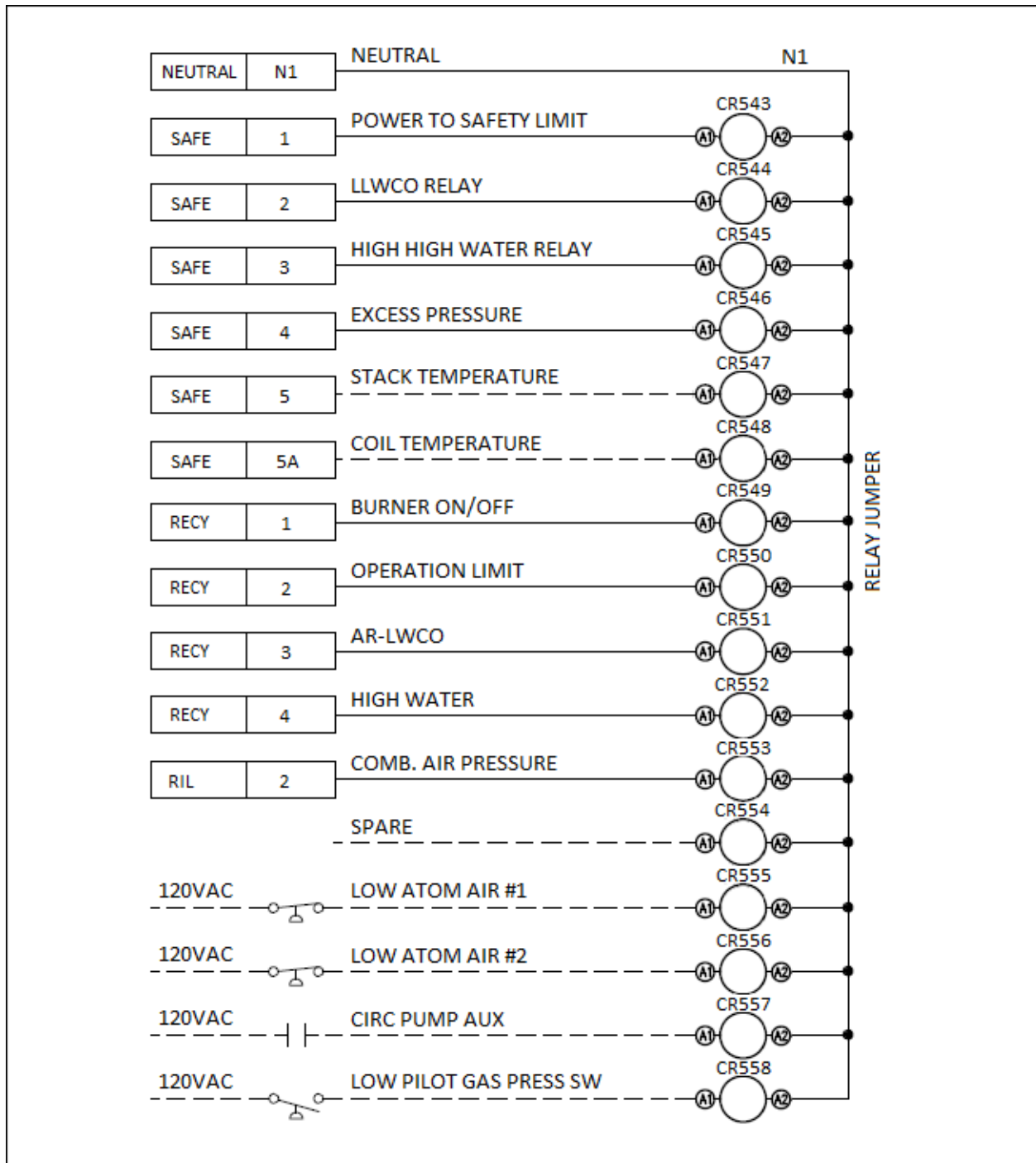

Connections (continued)

Standard annunciation sixteen(16) 120VAC inputs with additional three (4) inputs for draft control:

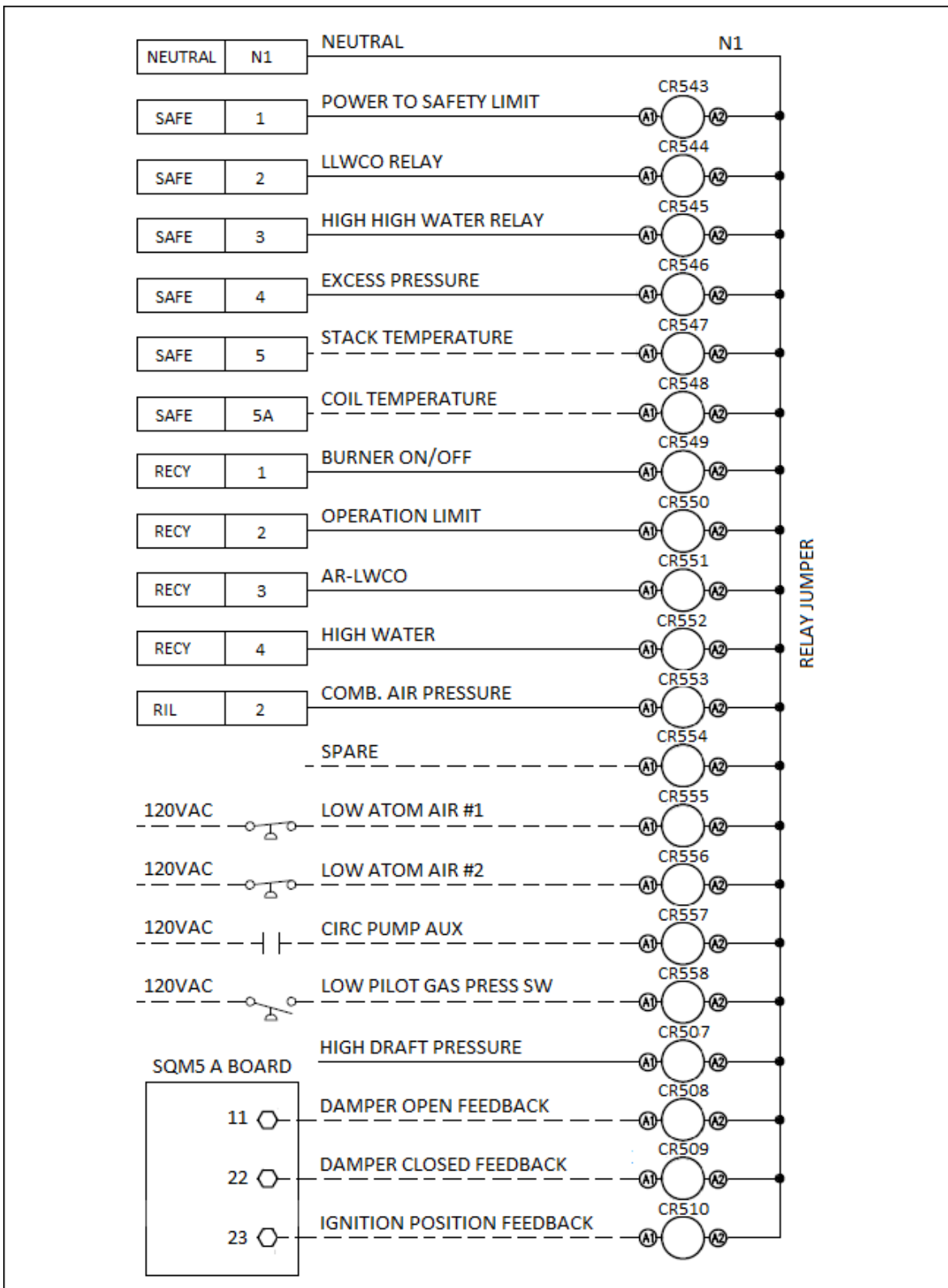

Connections (continued)

Output relay terminals:

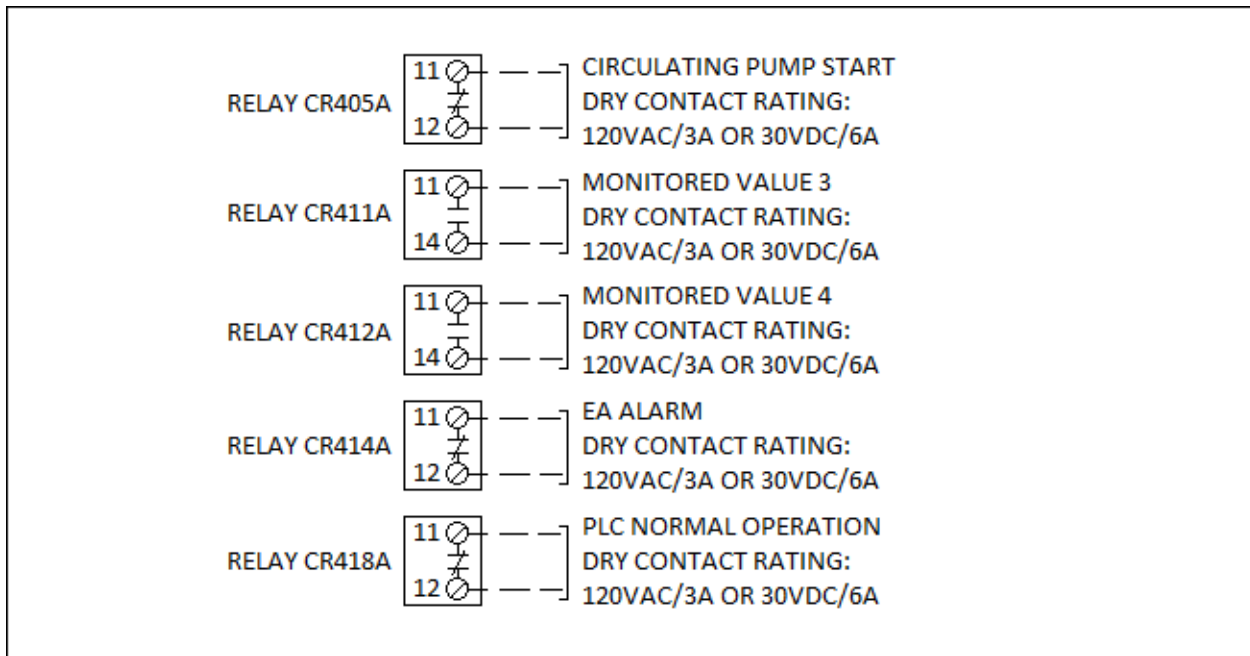

Connections (continued)

Additional output relay terminals:

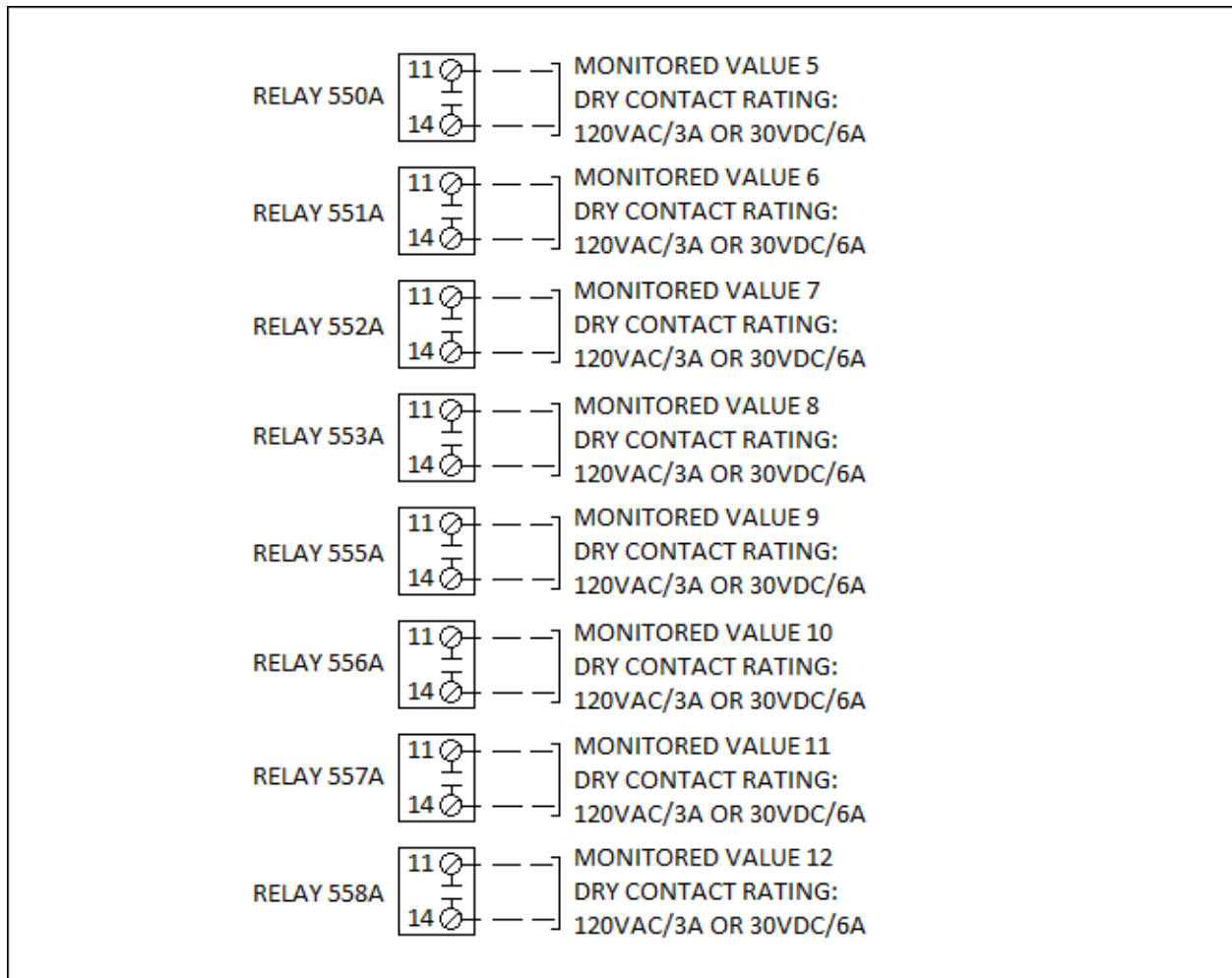

Connections (continued)

Analog input terminals:

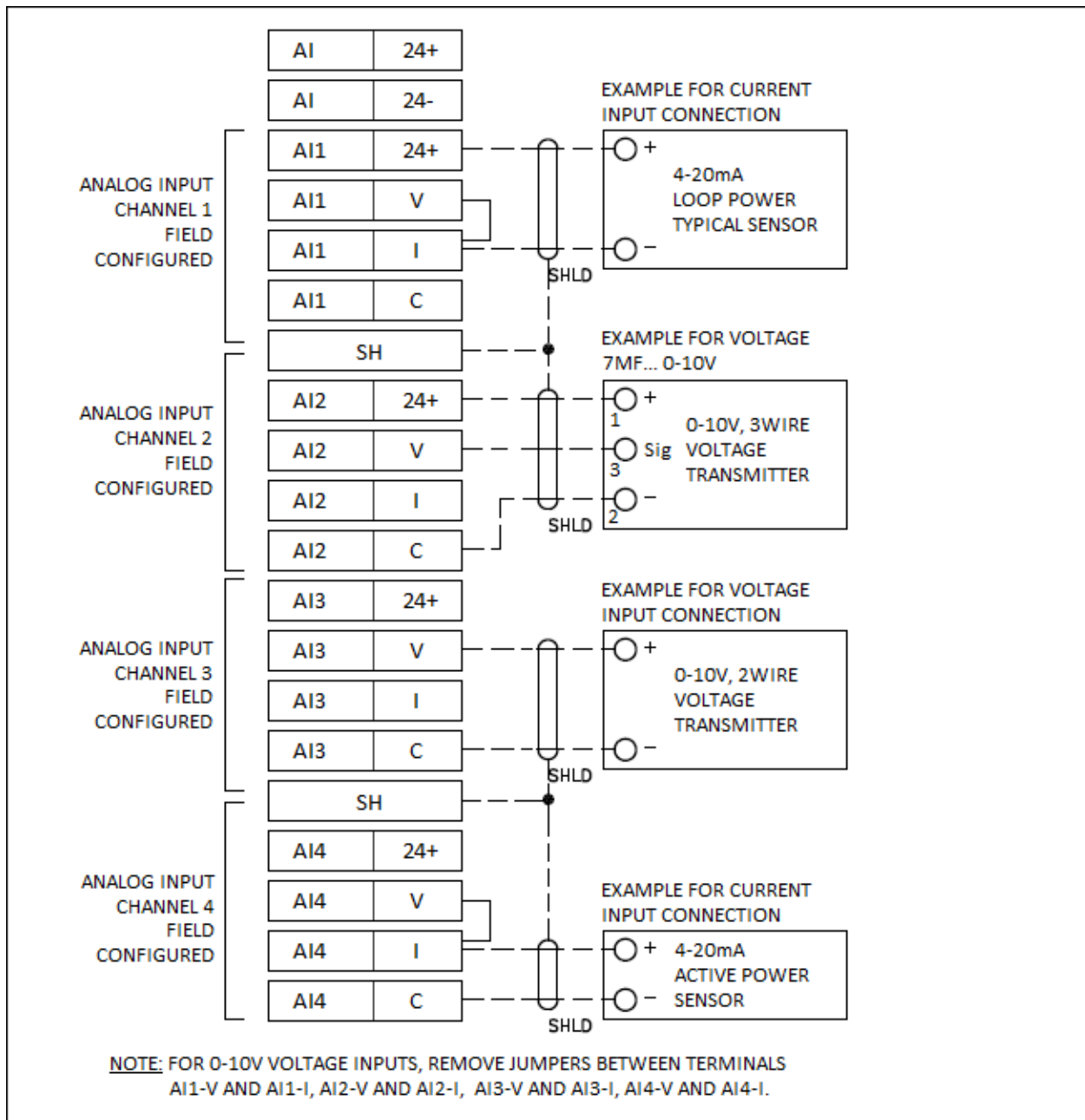

Connections (continued)

Analog output terminals:

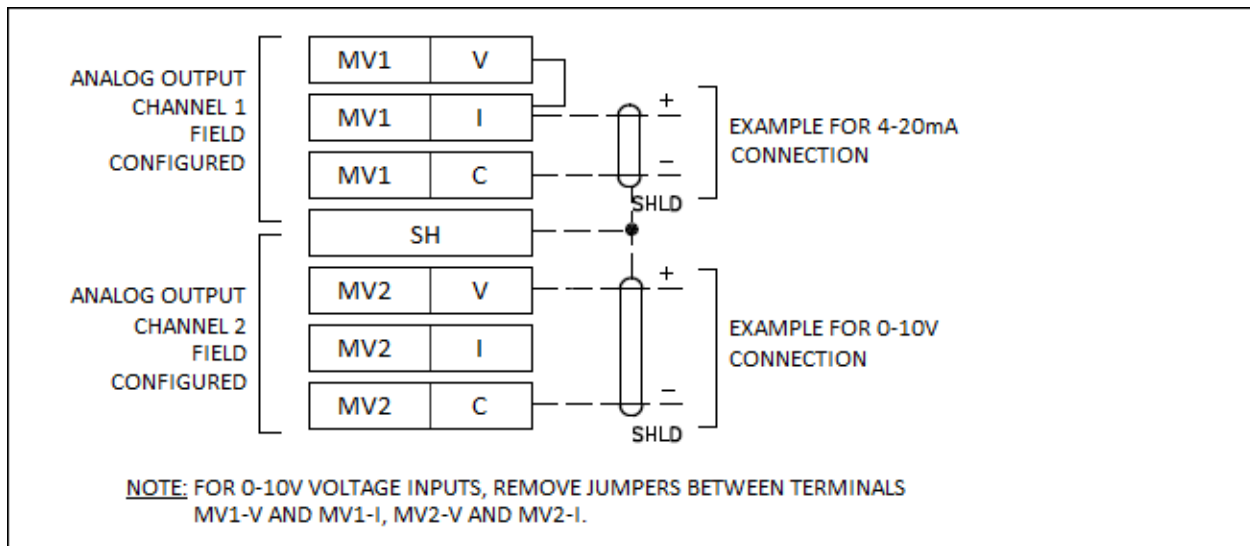

Dedicated analog outputs option, used for feedwater and circulating pump VFD control, 4-20mA only terminals:

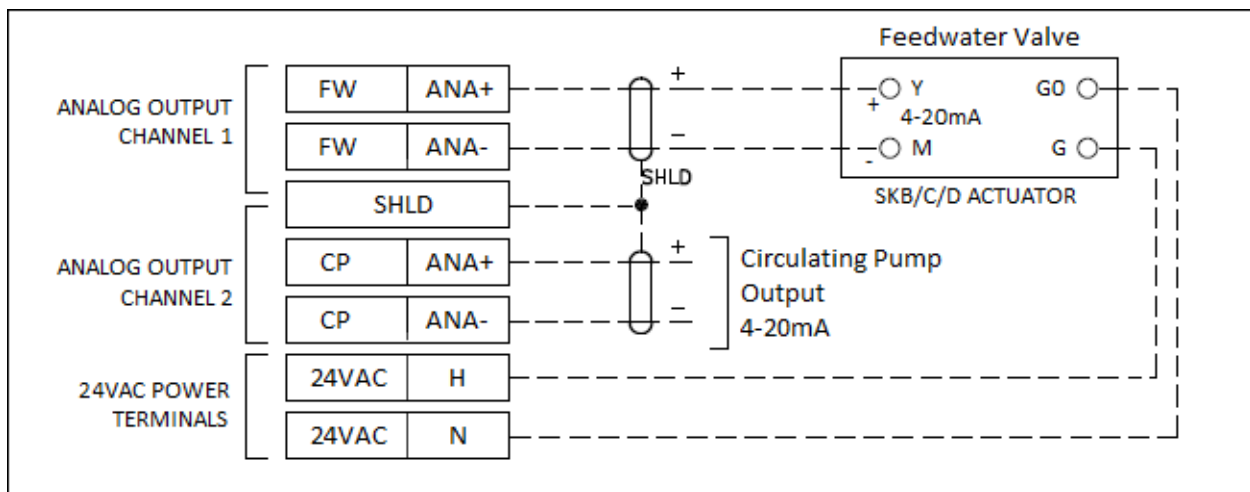

Connections (continued)

Universal input configured for 4-20mA

The first four universal input terminals with current transmitter example connections:

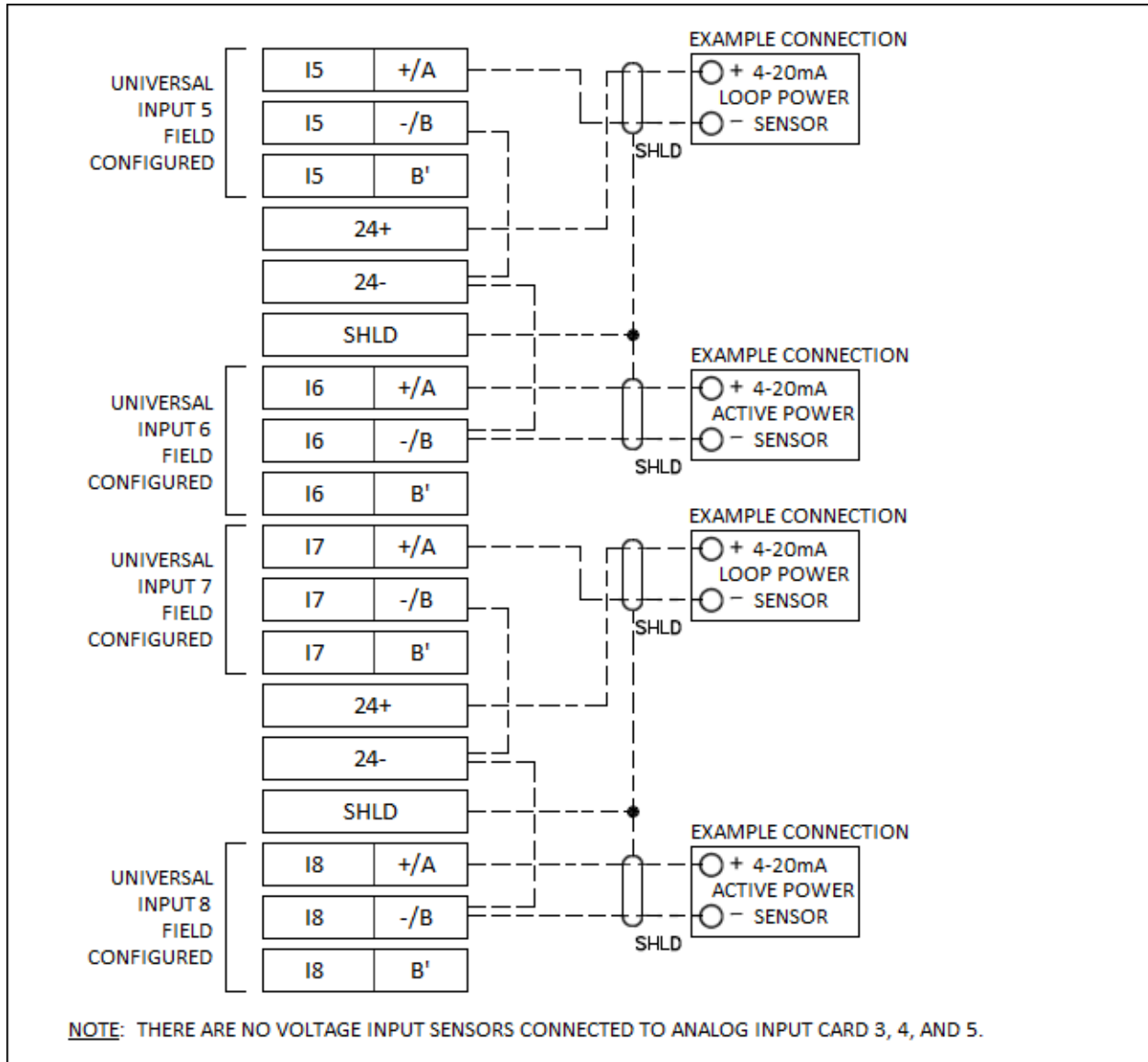

Connections (continued)

Universal inputs configured for RTD 1000 Ohm

The first four universal input terminals with RTD 1000 Ohm example connections:

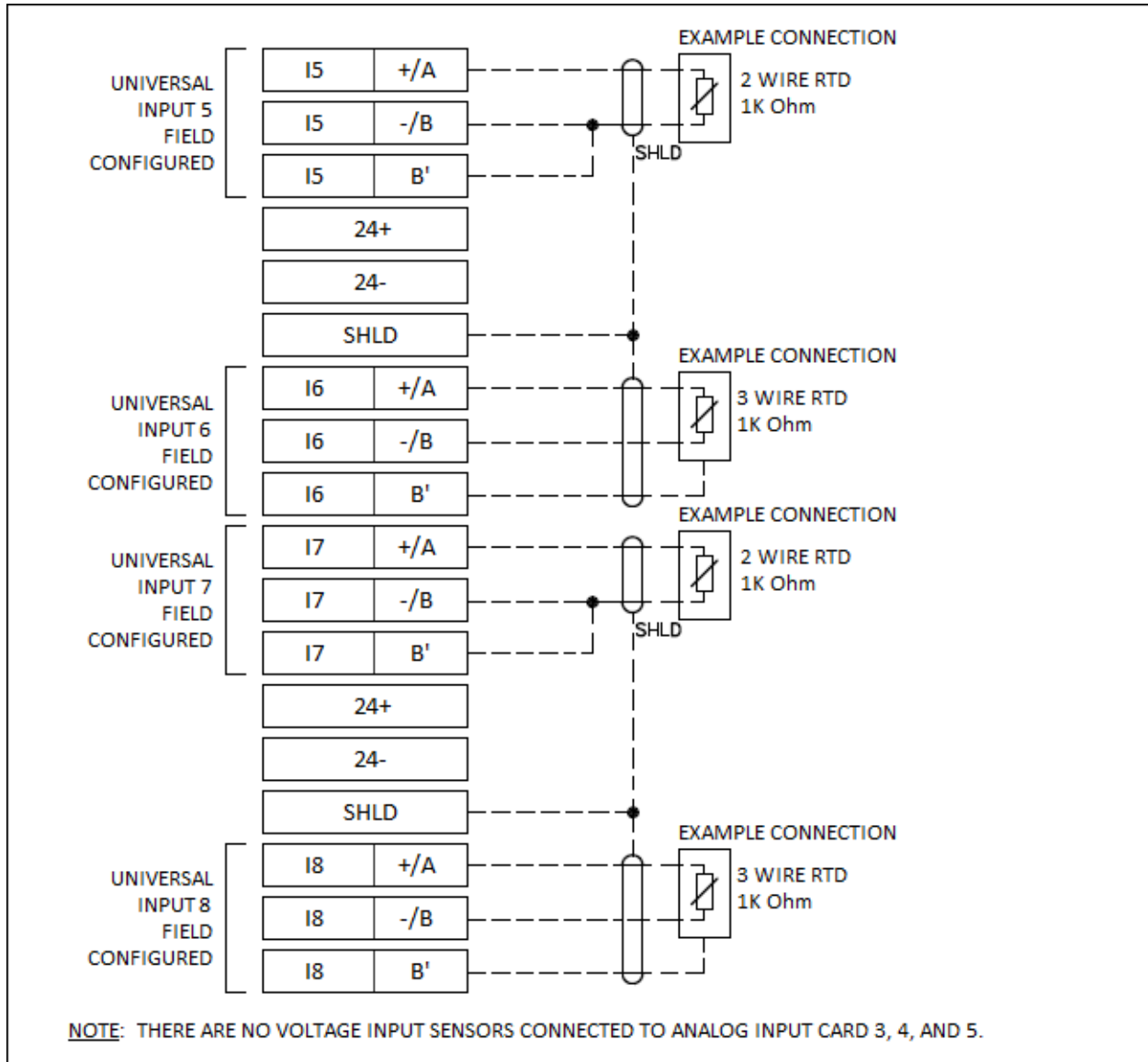

Connections (continued)

Universal input configured for 100 Ohm RTD

The first four universal input terminals with RTD 100 Ohm example connections:

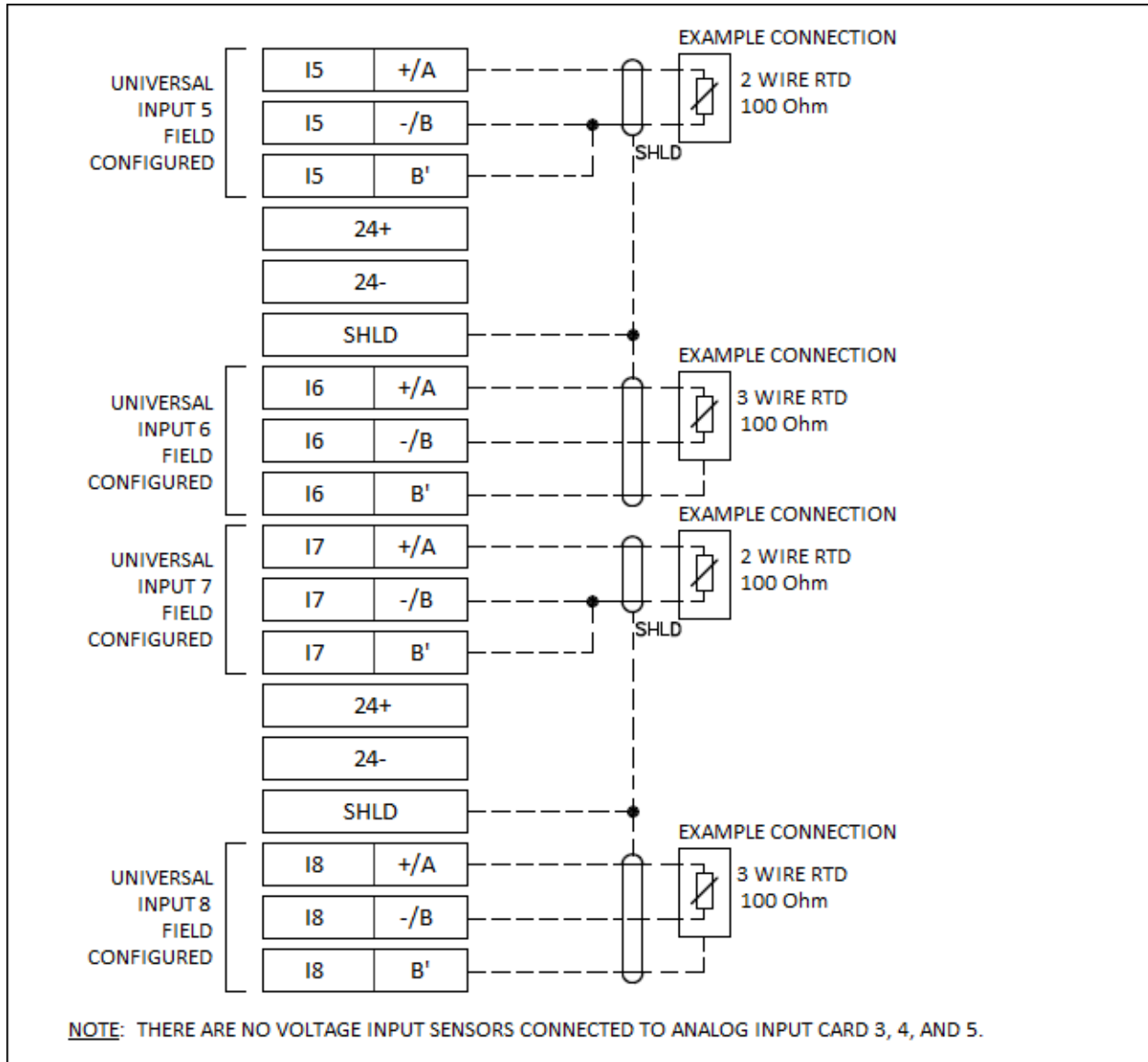

Connections (continued)

Universal input configured for Thermocouple either Type K, or J

The first four universal input terminals with thermocouple type J/K example connections:

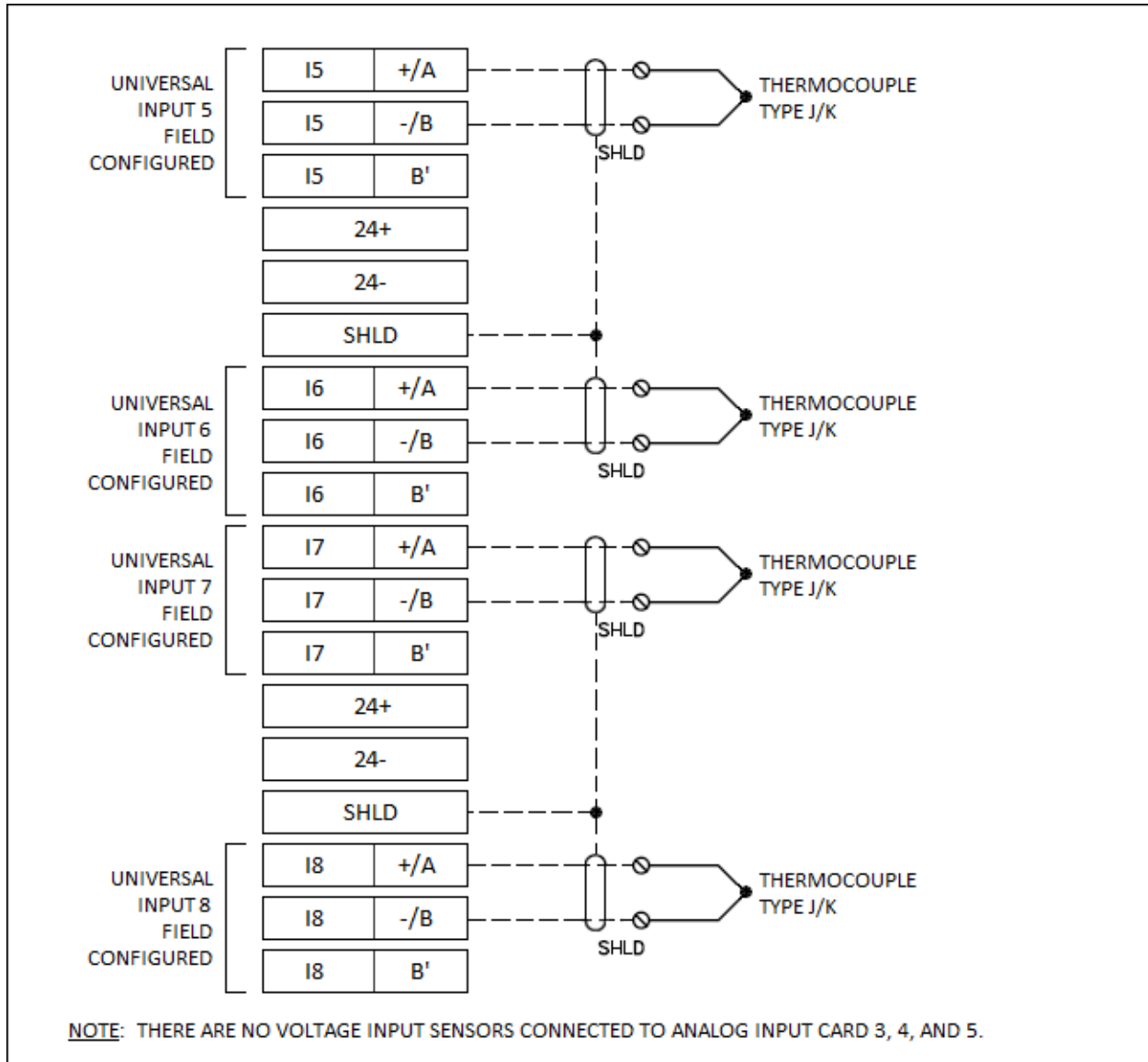

Connections (continued)

Universal input configured for 4-20mA

The second four universal input terminals with current transmitter example connections:

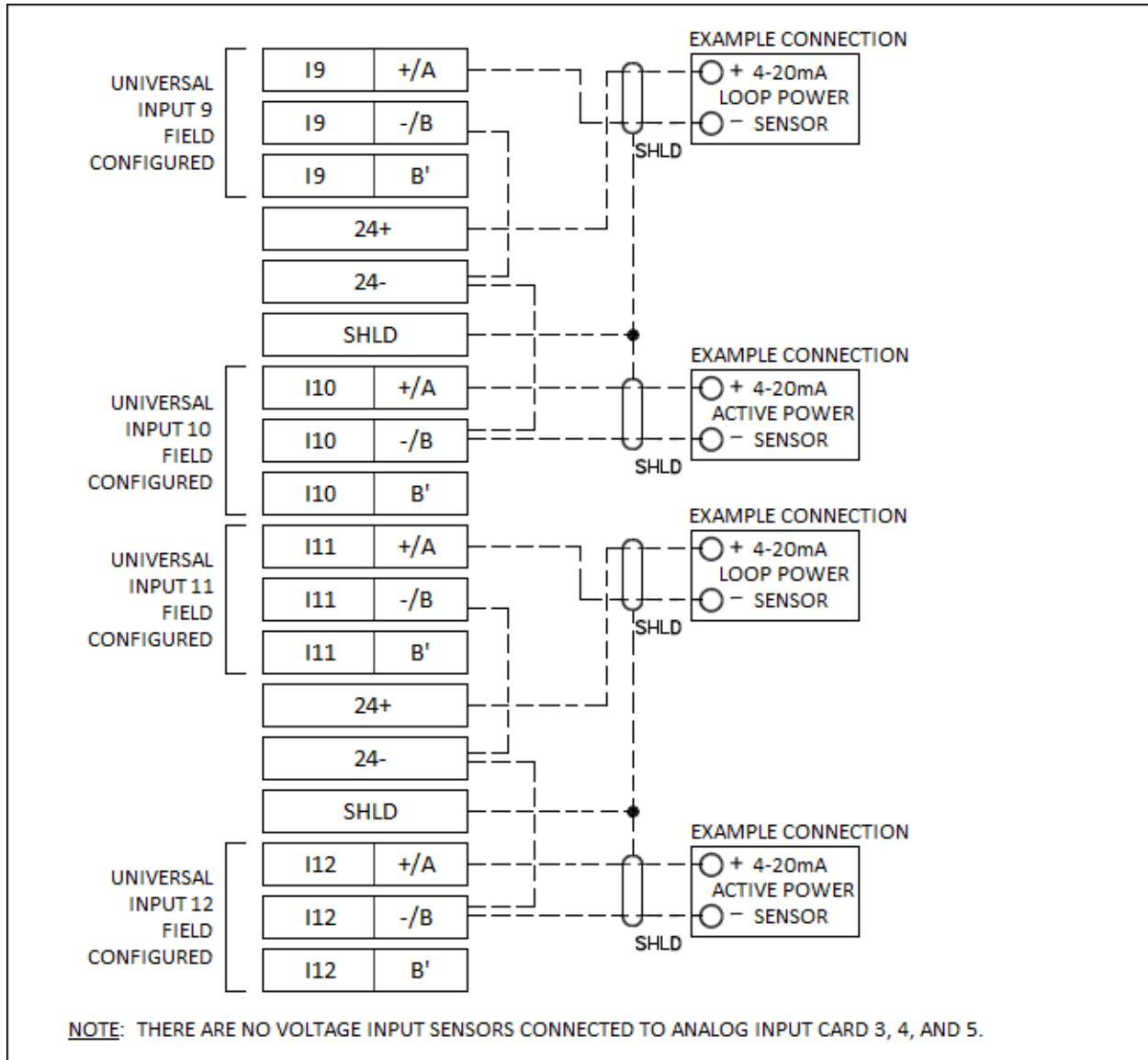

Connections (continued)

Universal input configured for 1000 Ohm RTD

The second four universal input terminals with RTD 1000 Ohm connections:

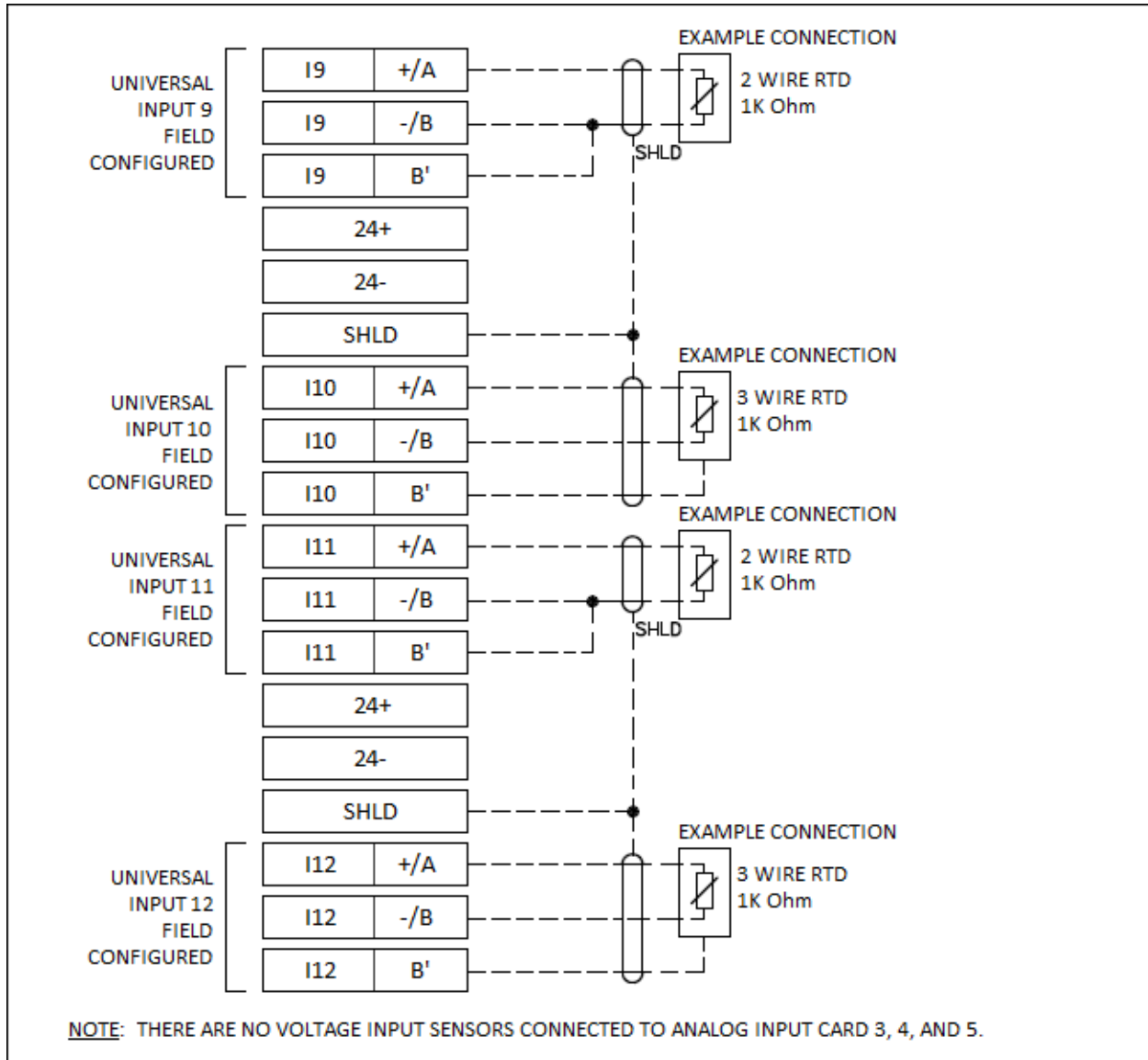

Connections (continued)

Universal input configured for 100 Ohm RTD

The second four universal input terminals with RTD 100 Ohm connections:

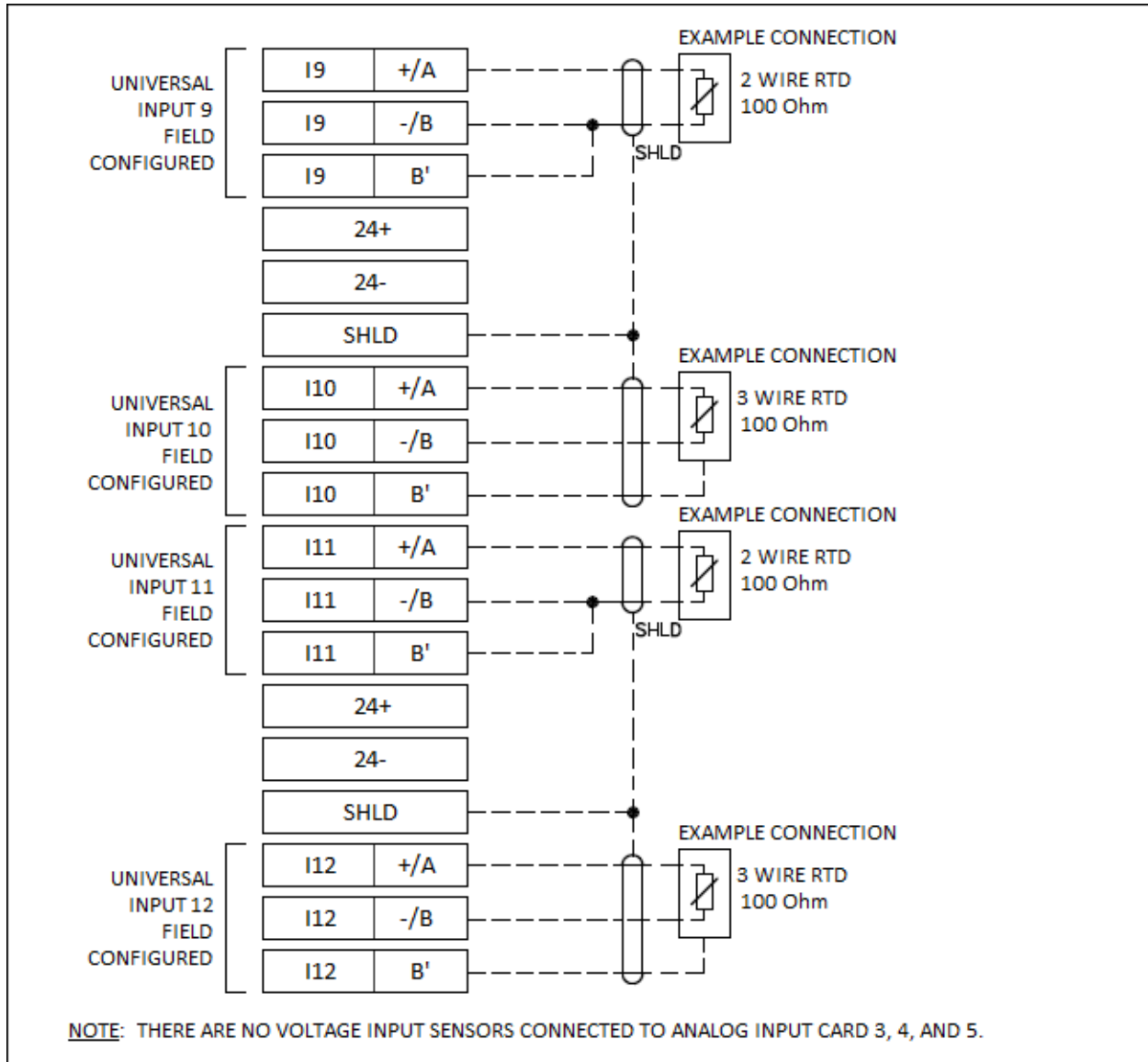

Connections (continued)

Universal input configured for Thermocouple either Type J, or K

The second four universal input terminals with thermocouple type J/K example connections:

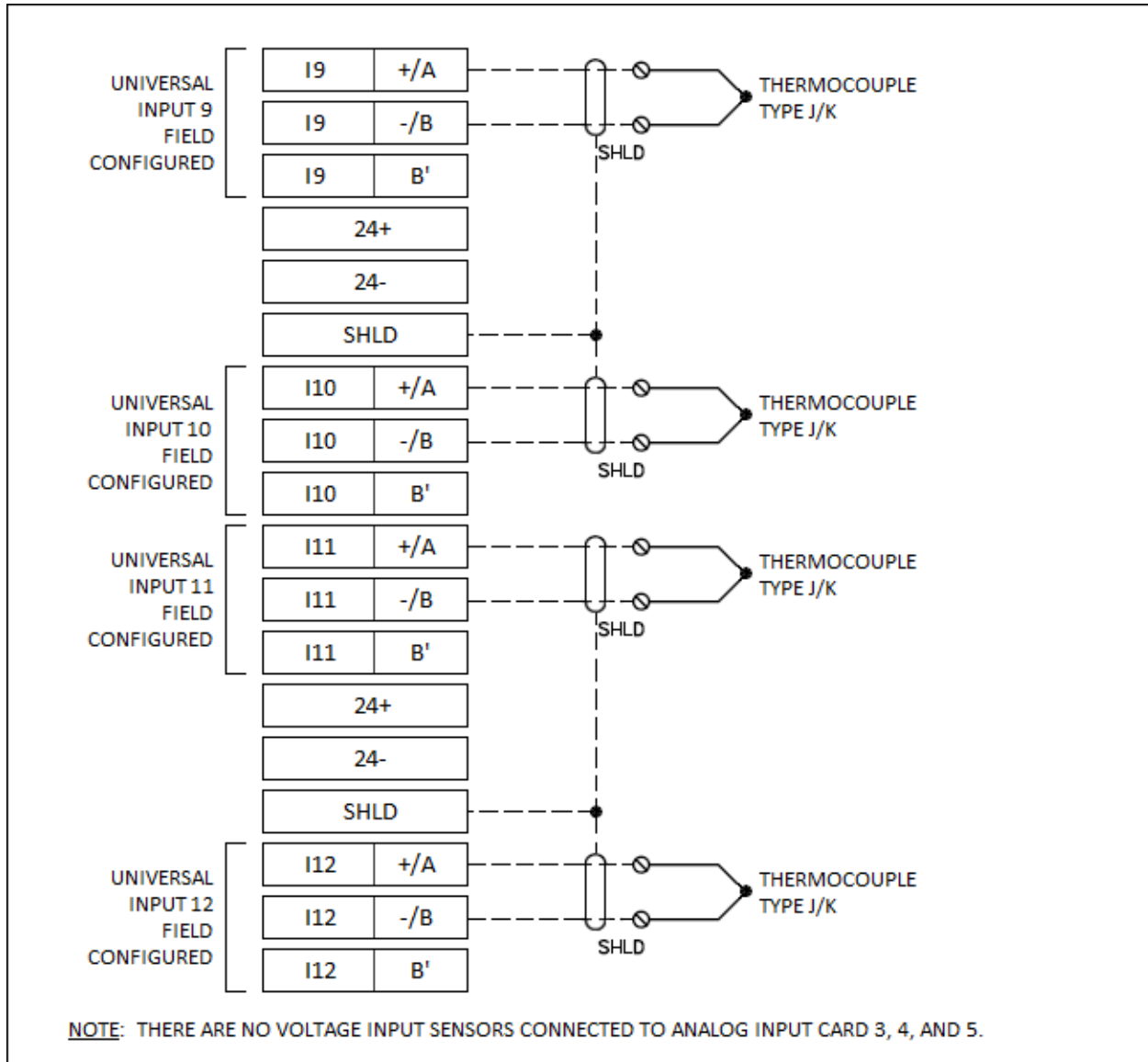

Connections (continued)

Universal input configured for 4-20mA

The third four universal input terminals with current transmitter connections:

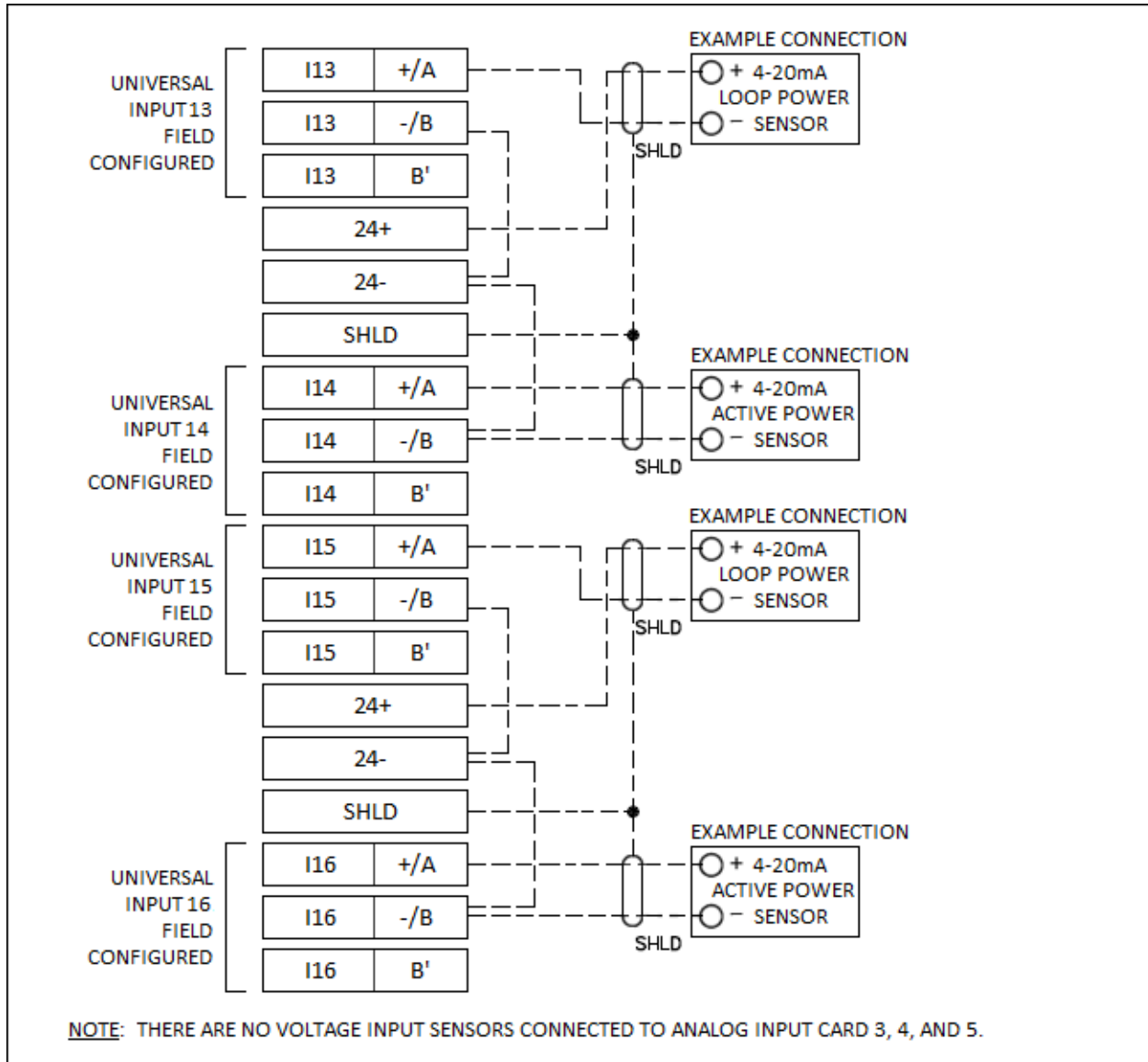

Connections (continued)

Universal input configured for 1000 Ohm RTD

The third four universal input terminals with RTD 1000 Ohm connections:

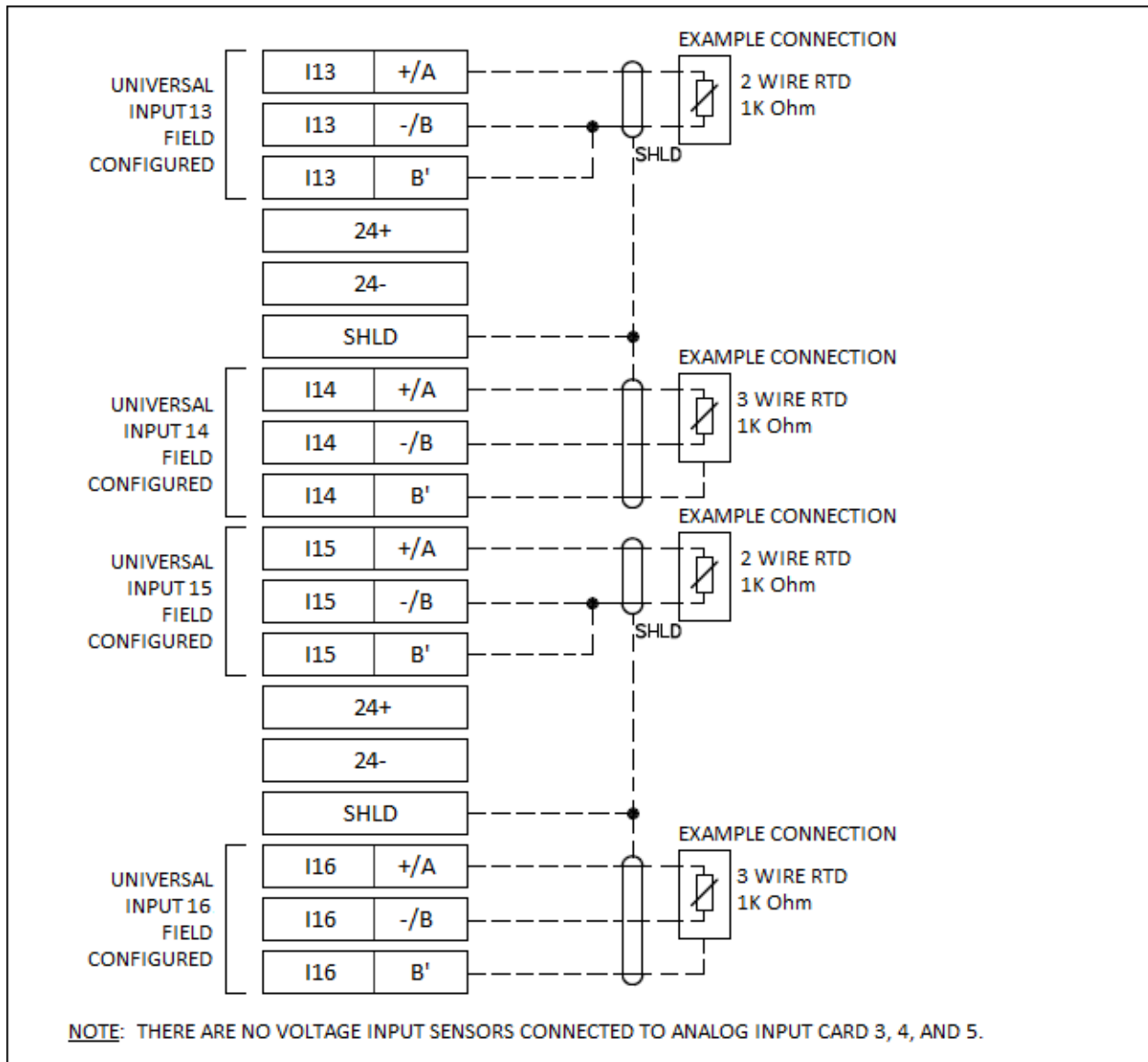

Connections (continued)

Universal input configured for 100 Ohm RTD

The third four universal input terminals with RTD 100 Ohm connections:

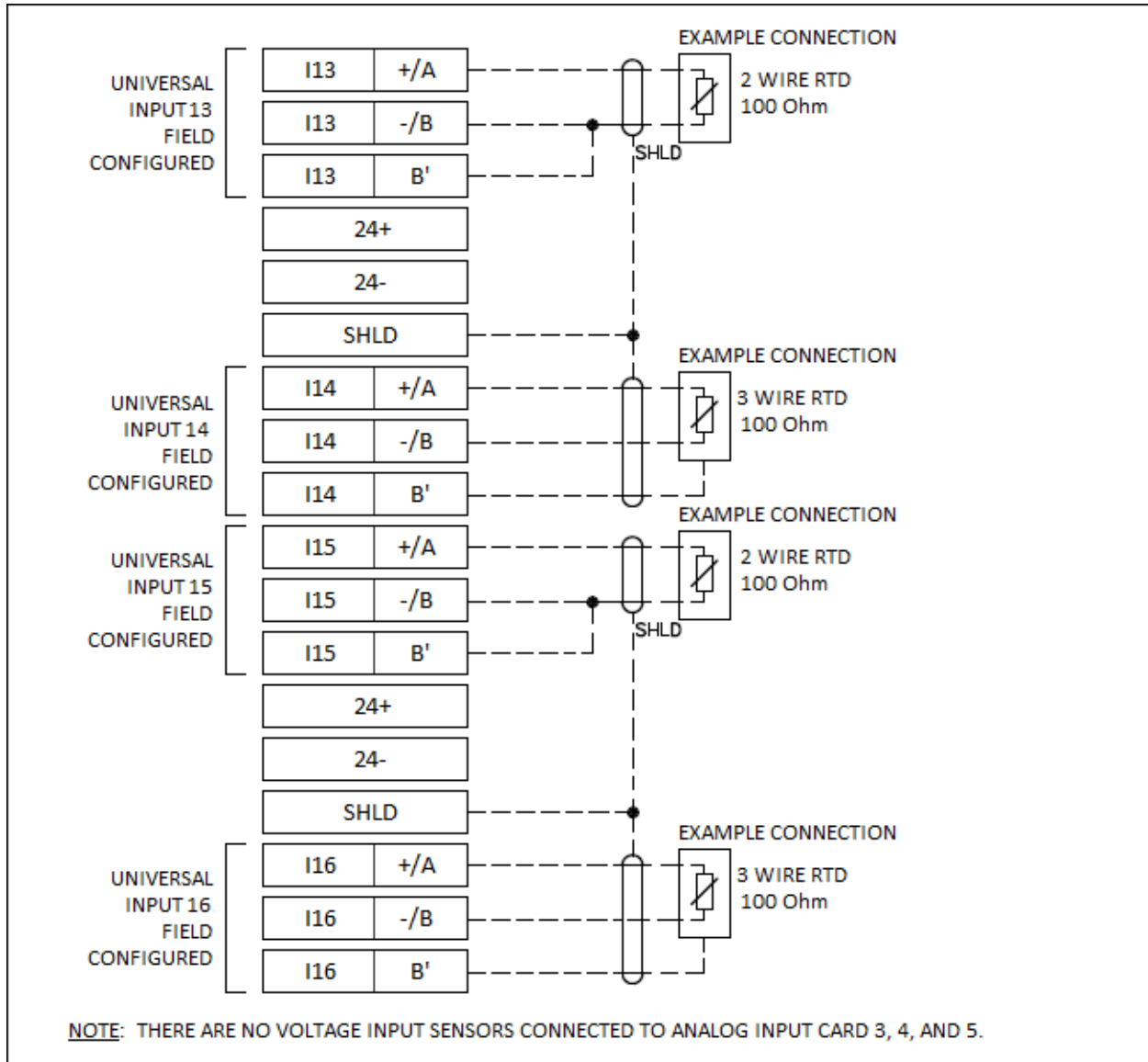

Connections (continued)

Universal input configured for Thermocouple either Type J, or K

The third four universal input terminals with thermocouple type J/K example connections:

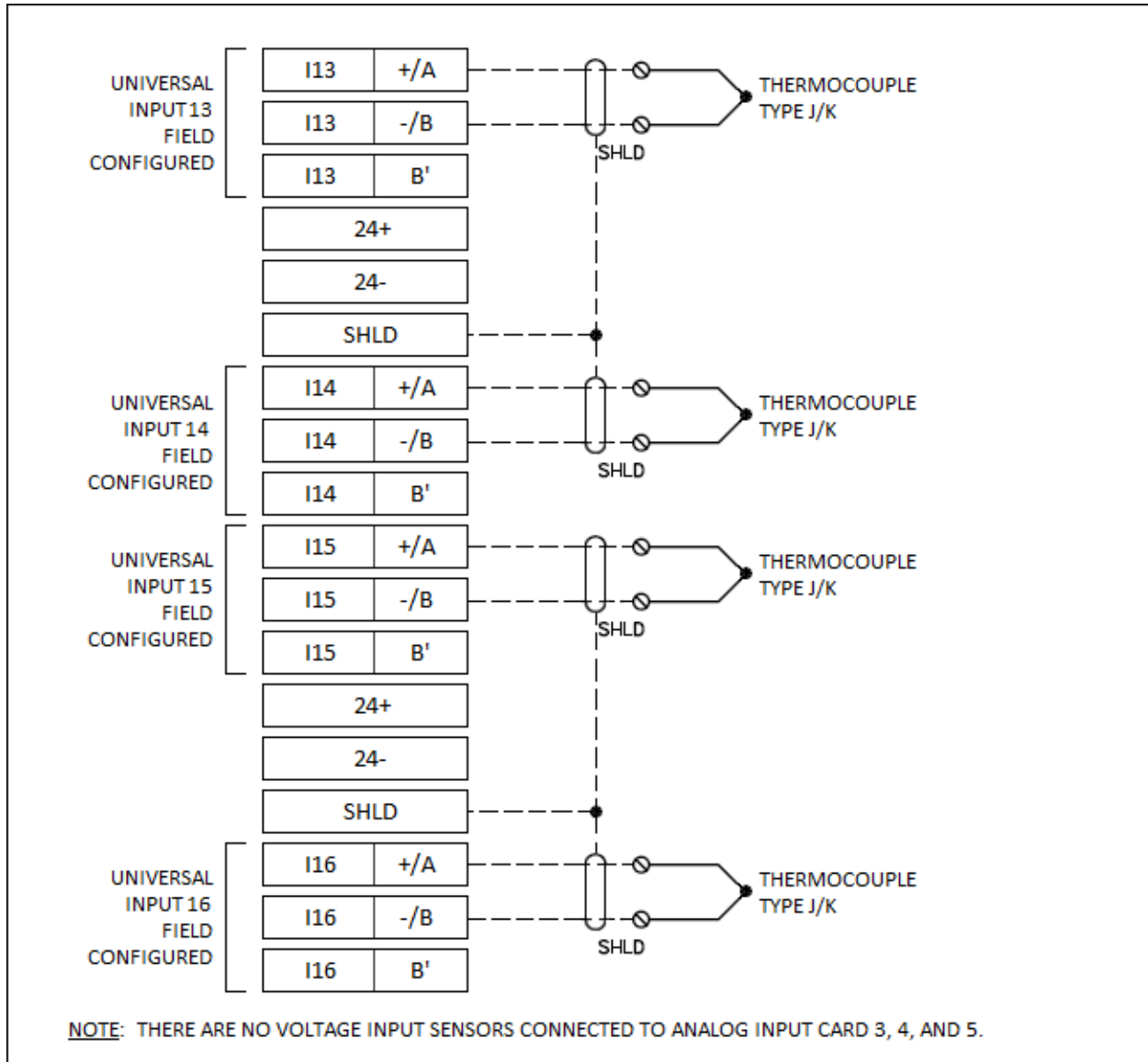

Connections (continued)

Draft Control:

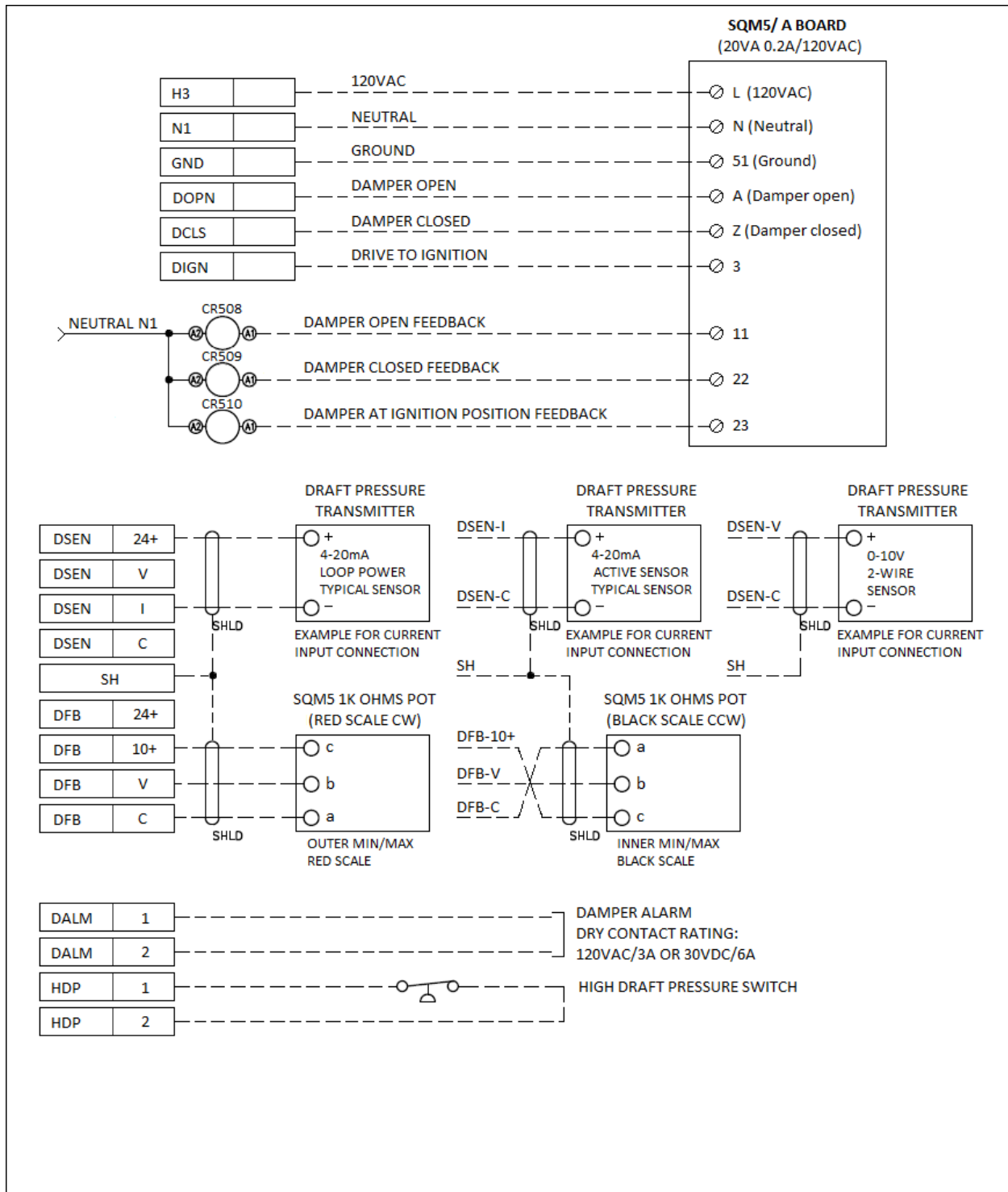

Connections (continued)

BMS Communication Connections

Standard Modbus TCP/IP with 6" touchscreen:

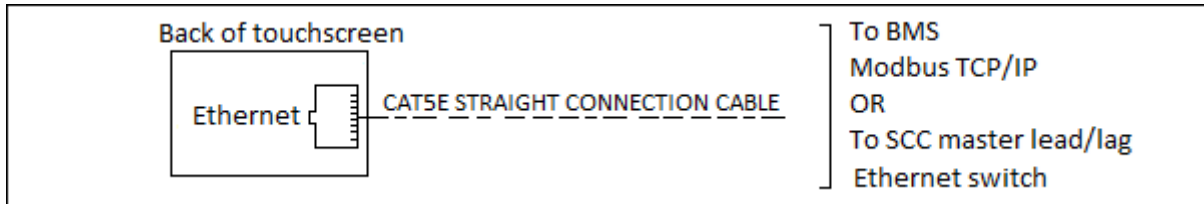

Standard Modbus TCP/IP with 7"/10"/12"/15" touchscreen:

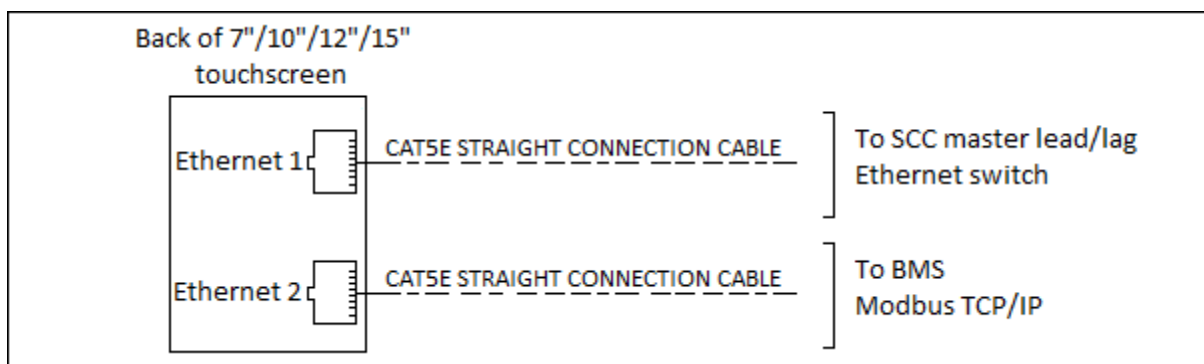

Standard Modbus TCP/IP with 6" touchscreen with PLC annunciation:

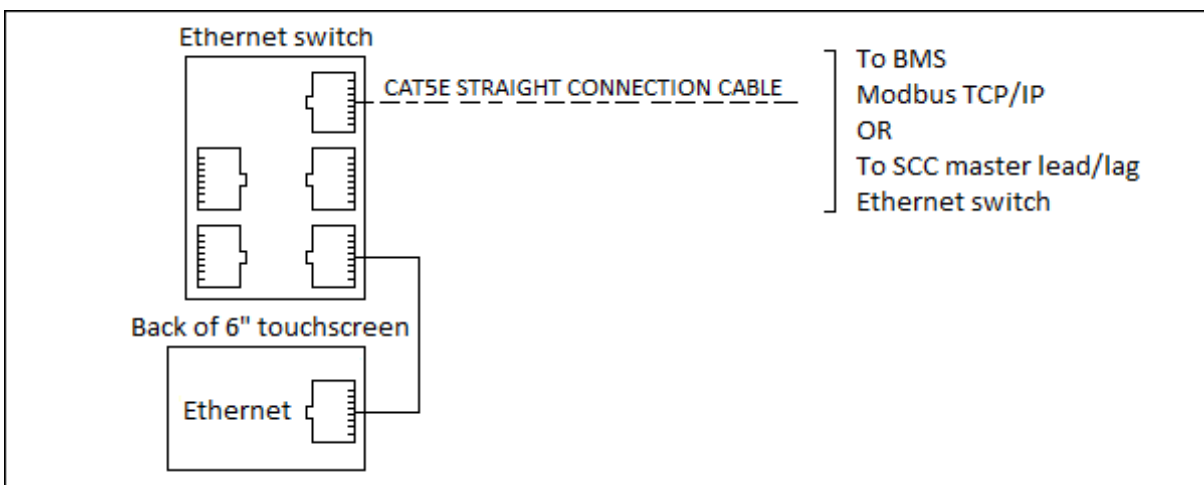

Connections (continued)

Standard Modbus TCP/IP with 7"/10"/12"/15" touchscreen with PLC annunciation:

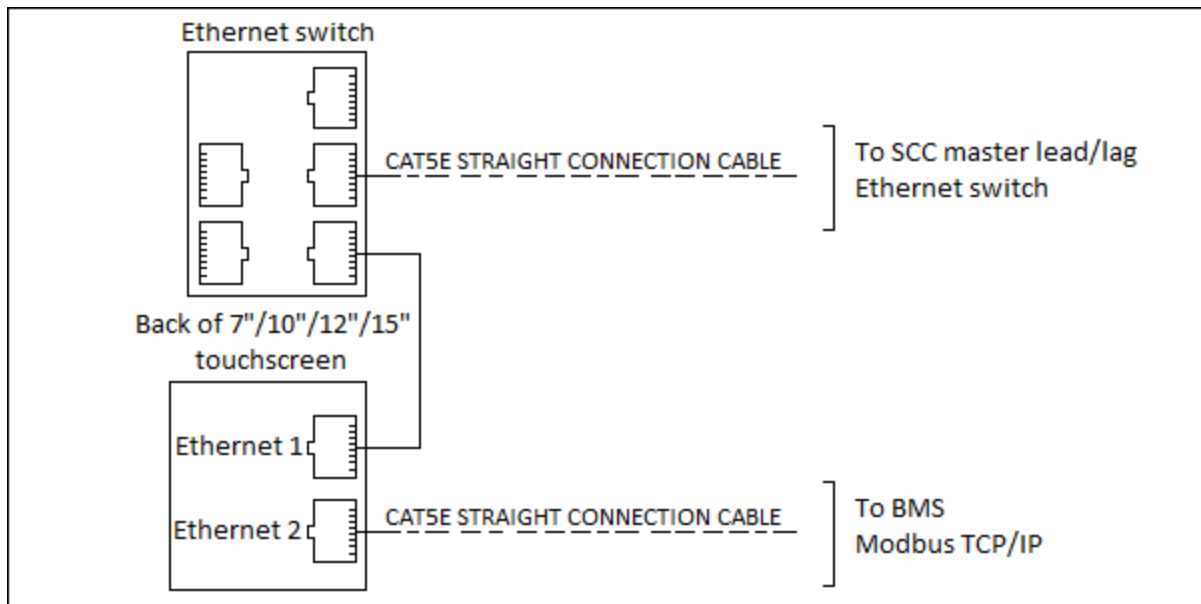

BACnet/IP, Ethernet/IP, or Modbus TCP/IP: Ethernet connection

BACnet MS/TP, N2 Johnson Metasys, or Modbus RTU: RS485 connection

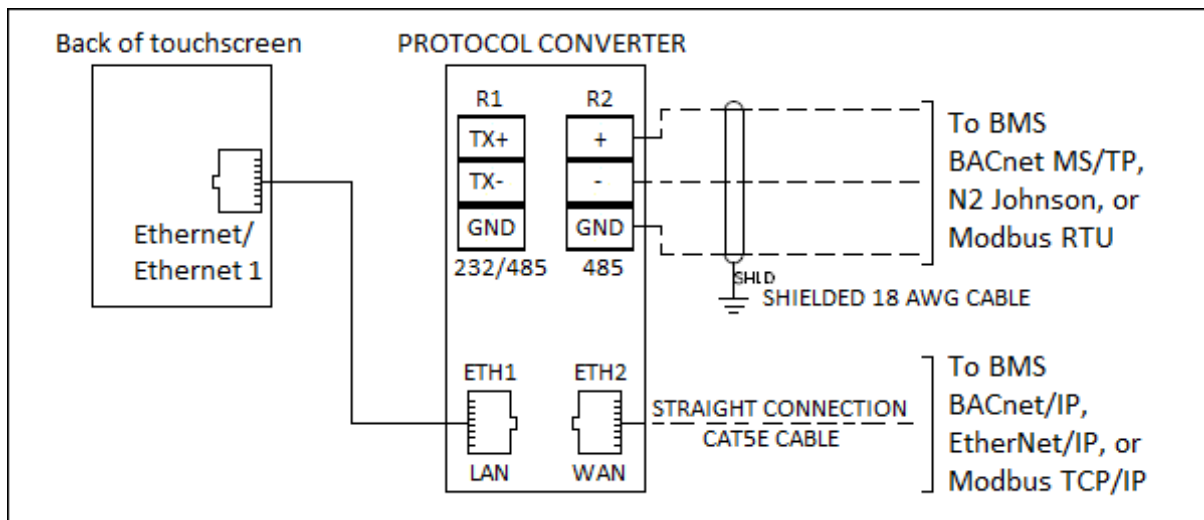

Connections (continued)

BACnet/IP, Ethernet/IP, or Modbus TCP/IP with PLC annunciation: Ethernet connection

BACnet MS/TP, N2 Johnson Metasys, or Modbus RTU with PLC annunciation: RS485 connection

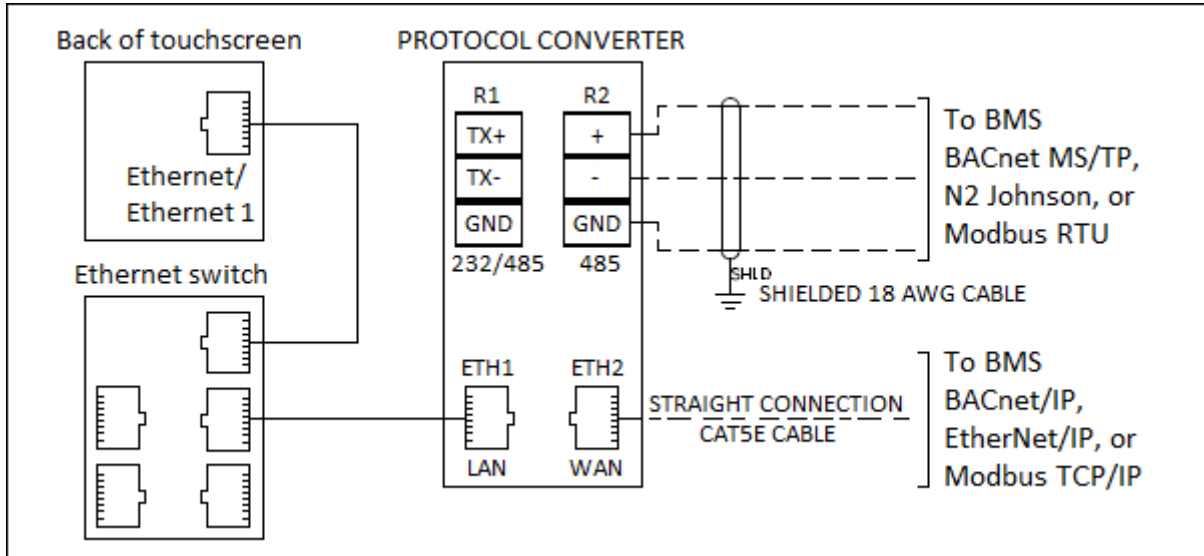

PROFINET:

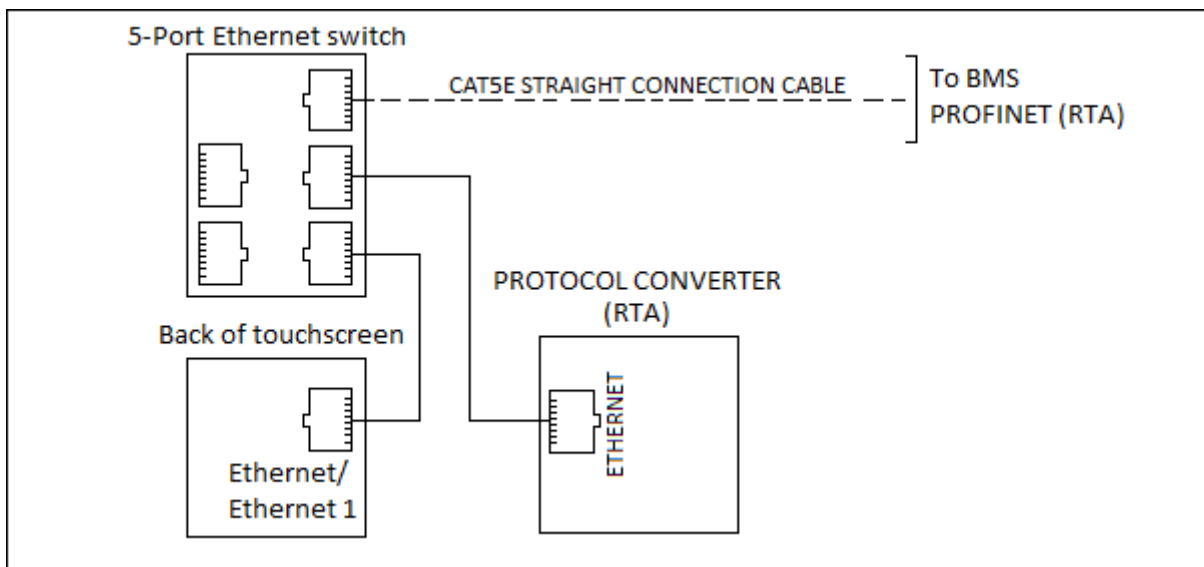

Connections (continued)

PROFIBUS:

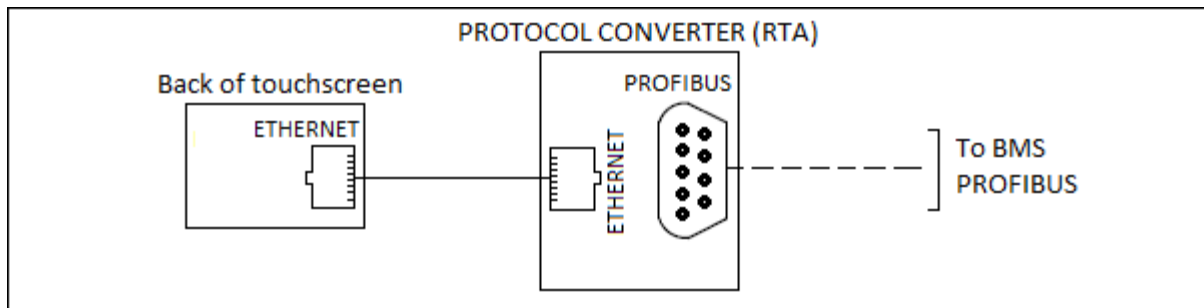

LonWorks:

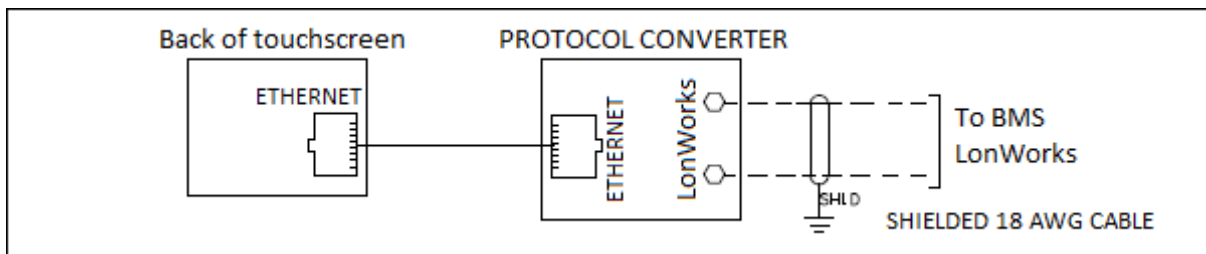

BMS serial connection RS232 without touchscreen:

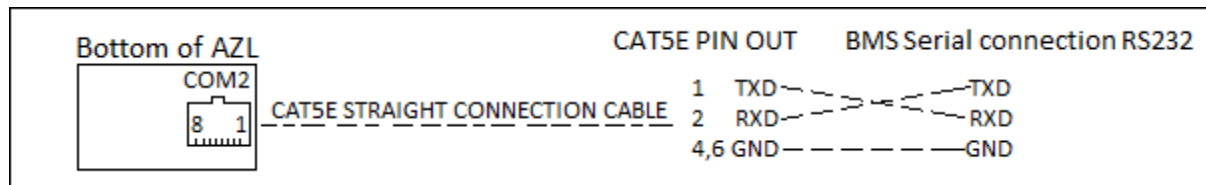

BMS serial connection RS485:

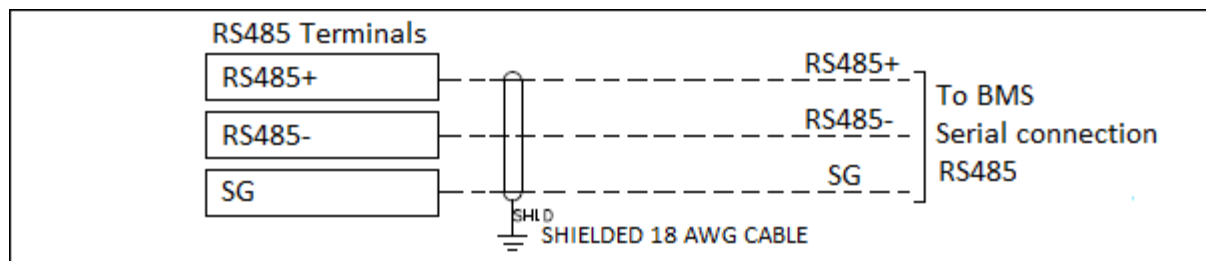

Parts Descriptions

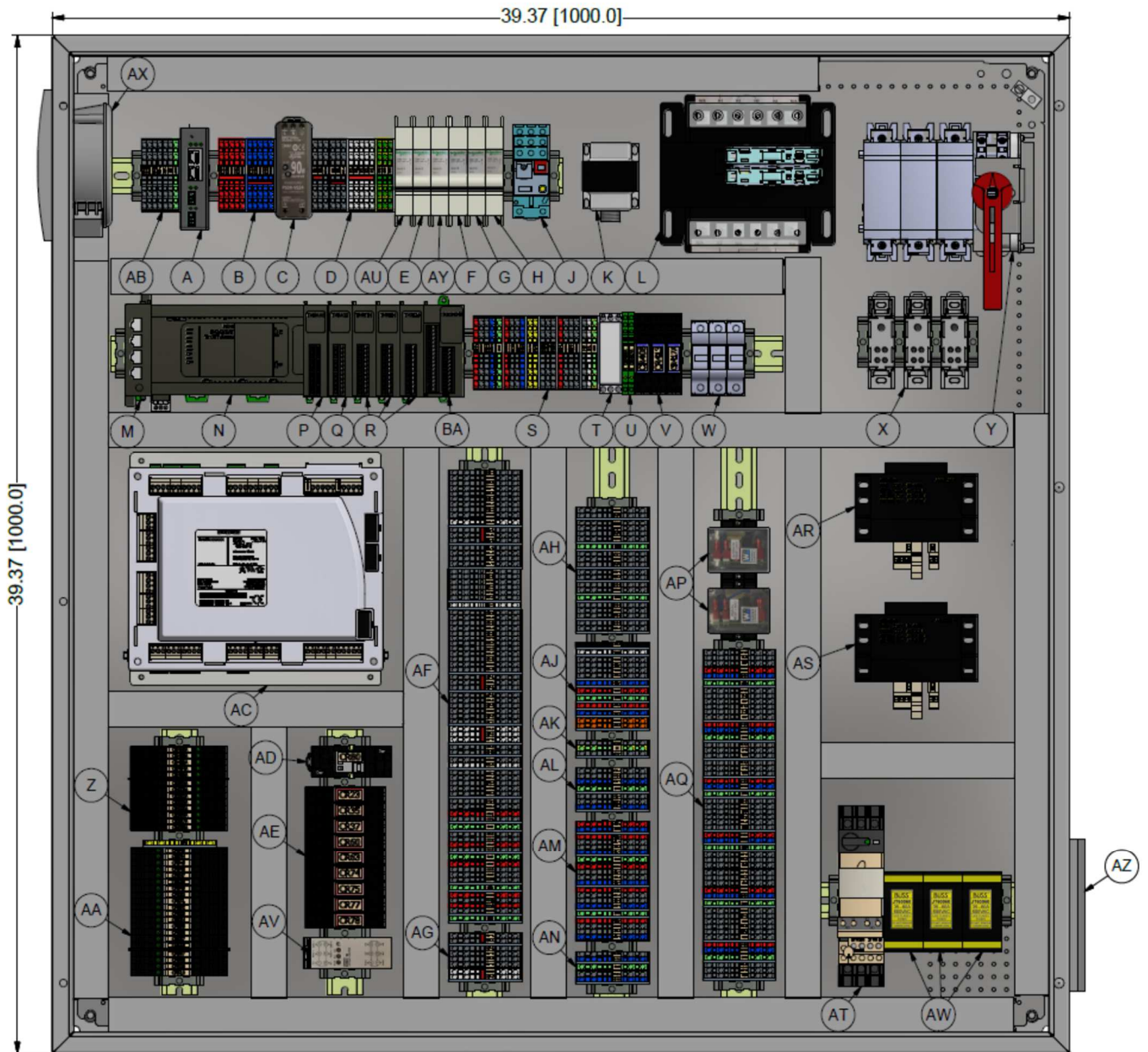

Parts Descriptions (continued)

A	Protocol Converter	BMS Communication Other than Modbus TCP/IP
B	24 VDC Terminals	Standard Component
C	24 VDC Power Supply	Standard Component
D	120 VAC and Ground Terminals	Standard Component
E	1 Amp Draft Control Circuit Breaker	Draft Control
F	3 Amp Load Control and Water Level Control Circuit Breaker	Load Control/Water Level Control
G	3 Amp 24 VDC Power Supply Circuit Breaker	Standard Component
H	10 Amp Main Circuit Breaker	Standard Component
J	Power Fail Relay	Standard Component
K	24 VAC SKB/C or D Transformer	Water Level Control
L	750/1000 VA Transformer	440 – 480 VAC
M	Ethernet Switch	Annunciation or BACnet/IP, or Ethernet/IP BMS Communication
N	Programmable Logic Controller (PLC)	Annunciation or Draft Control
P	Analog I/O Module	(4) Dedicated Analog Inputs and (2) Analog Outputs
Q	Analog Output Module	PLC Feedwater/Water Level or Circulating Pump VFD Control
R	Analog Input Module(s)	(4) Universal Inputs per Module
S	Draft Control Terminals	Draft Control
T	Off Delay Timer	Draft Control
U	24 VDC Solid State Relays	Draft Control
V	24 VDC DPDT Relays	Draft Control
W	4A Fuses	(2) AGG5.210 Transformers

X	Power Distribution Blocks	440 – 480 VAC
Y	Disconnect Switch	Standard Component Fused with 440 – 480 VAC Non-Fused with 110 – 120 VAC
Z	24 VDC SPDT Output Relays	Annunciation
AA	120 VAC SPDT Relays	Annunciation/Draft Control
AB	Modbus RS232 and RS485 Terminals	Standard Component
AC	LMV5	Standard Component
AD	DPDT LMV5 Lockout Relay	Standard Component
AE	DPDT LMV5 Output Relays	Standard Component
AF	LMV5 Terminals (Safety Limit, Running Interlocks, Recycle Limits, Auxiliary Devices, Pilot and Gas Train, Ignition Transformer, Flame Scanner, HVAC)	Standard Component
AG	Oil Train Terminals	Dual Fuel/Single Fuel, Oil
AH	Load Control Terminals	Load Control
AJ	Water Level Control Terminals	Water Level Control
AK	12 VAC Terminals	(2) AGG5.210 Transformers
AL	Analog Output Terminals	(4) Dedicated Analog Inputs and (2) Analog Outputs
AM	Dedicated Analog Input Terminals	(4) Dedicated Analog Inputs and (2) Analog Outputs
AN	PLC Feedwater/Water Level and Circulating Pump VFD Control Terminals	PLC Feedwater/Water Level and Circulating Pump VFD Control
AP	Automatic/Manual Reset Warrick Relay	Auto and Manual Reset Warrick Relay
AQ	Universal Input Terminals	(4), (8) or (12) Additional Universal Input Terminals
AR	AGG5.210 Transformer	Standard Component
AW	Fuse Holders/Fuses	VSD Control for Blower Motor

Parts Descriptions (continued)

AS	2 nd AGG5.210 Transformer	(2) AGG5.210 Transformers
AT	Motor Starters	Up to (3) Motor Starters for Blower, Oil Pump or Compressor
AU	1A RS232 to RS485 Converter Breaker	Modbus RTU RS485
AV	RS232 to RS485 Converter	Modbus RTU RS485

AX	Cooling Fan	Cooling Fan
AY	2A Cooling Fan Breaker	Cooling Fan
AZ	Air Intake Filter	Cooling Fan
BA	Digital Input/Output Module	(16) Additional Digital inputs and (8) Additional Digital Outputs

Combustion Enclosure Layouts General Note:

Reference pages 41-42 for item balloon descriptions

Lowercase "x" in part number denotes any selection

Dimensions in inches; millimeters in brackets

TS-CExxx-xxxX-xxxx-XXXX

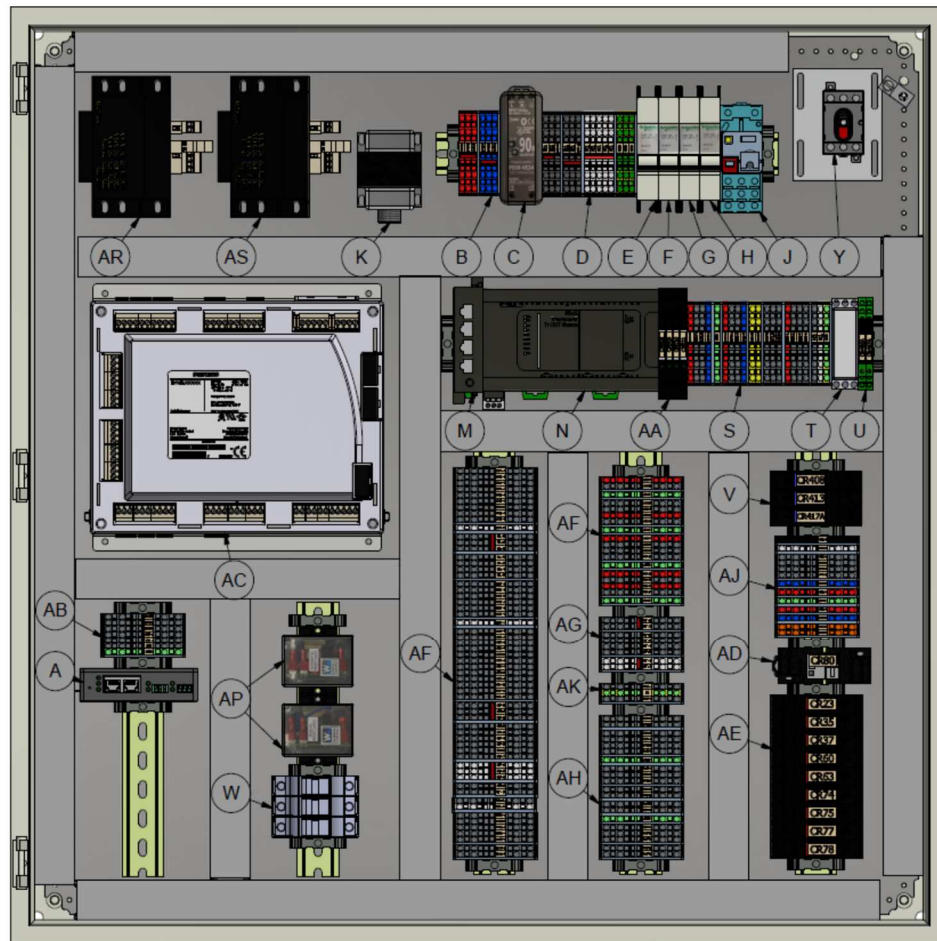

TS-CE226-xDXX-Bx32-XXXX

Options for Kit in Enclosure	(2) AGG5.210 Transformers Components (W, AK, AS)	Water Level Control Components (F, K, AJ)	Load Control Components (F, AH)	*Draft Control Components (E, N, S, T, U, V, AA)	Warrick Relays (AP)
TS-CE22x-xxXX-Bx2x-XXXX	X				
TS-CE2x3-xxXX-Bx2x-XXXX		X			
TS-CE2x4-xxXX-Bx2x-XXXX			X		
TS-CE2xx-xDXX-Bx2x-XXXX				X	
TS-CE2xx-xxXX-B32x-XXXX					X

Notes:

- 24"x24" Enclosure used with (0-1) options
- 32"x32" Enclosure used with (2) or more options
- * Option not available in 24"x24" enclosure

TS-CExxx-xxxX-xxxx-4xxx

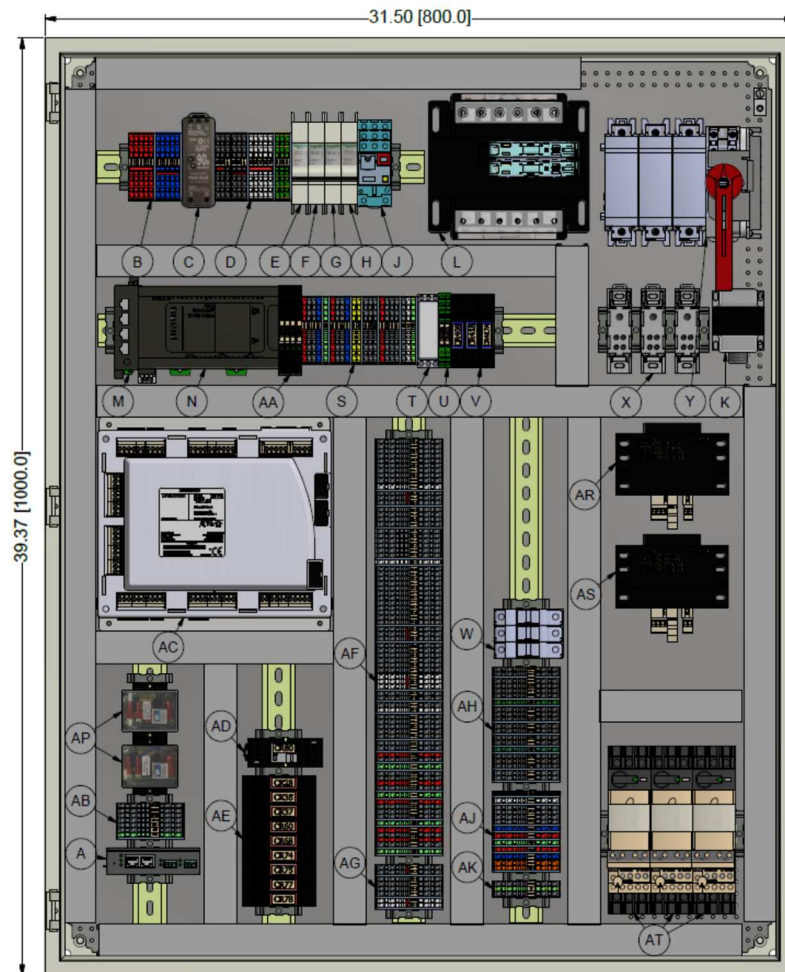

TS-CE226-xDXX-Bx32-4CAC

Options for Kit in Enclosure	(2) AGG5.210 Transformers Components (W, AK, AS)	Water Level Control Components (F, K, AJ)	Load Control Components (F, AH)	Draft Control Components (E, N, S, T, U, V, AA)	Warrick Relays (AP)	Motor Starters (AT)
TS-CE22x-xxXX-Bx2x-4xxx	X					
TS-CE2x3-xxXX-Bx2x-4xxx		X				
TS-CE2x4-xxXX-Bx2x-4xxx			X			
TS-CE2xx-xDXX-Bx2x-4xxx				X		
TS-CE2xx-xxXX-B32x-4xxx					X	
TS-CE2xx-xxXX-Bx2x-4CAC						X

32"x32" Enclosure used with (0-1) options
40"x32" Enclosure used with (2) or more options

TS-CExxx-xxxA-xxxx-XXXX

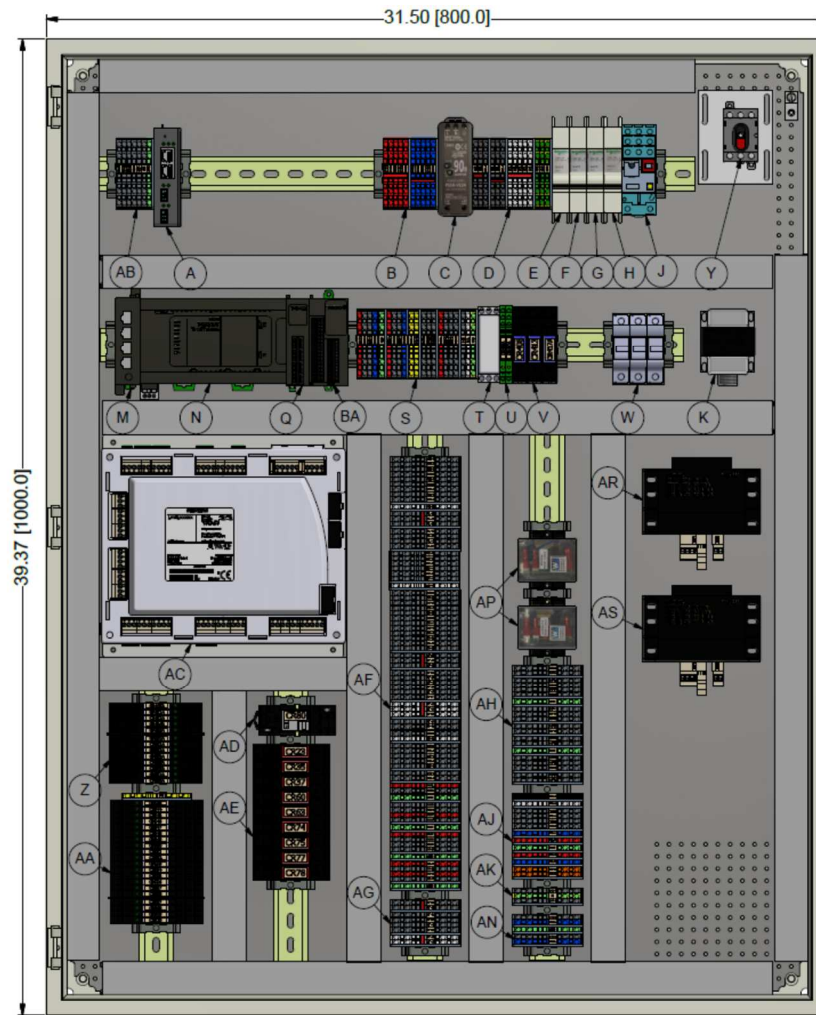

TS-CE226-xD6A-Bx32-XXXX

Options for Kit in Enclosure	(2) AGG5.210 Transformers Components (W, AK, AS)	Water Level Control Components (F, K, AJ)	Load Control Components (F, AH)	Draft Control Components (E, S, T, U, V)	PLC Output Components (Q, AN)	Additional Digital Inputs and Outputs (BA)	Warrick Relays (AP)
TS-CE22x-xxxA-Bx2x-XXXX	X						
TS-CE2x3-xxxA-Bx2x-XXXX		X					
TS-CE2x4-xxxA-Bx2x-XXXX			X				
TS-CE2x4-xDxA-Bx2x-XXXX				X			
TS-CE2x4-xx3A-Bx2x-XXXX					X		
TS-CE2x4-xx6A-Bx2x-XXXX						X	
TS-CE2x4-xxxA-B32x-XXXX							X

TS-CExxx-xxxA-xxxx-4xxx

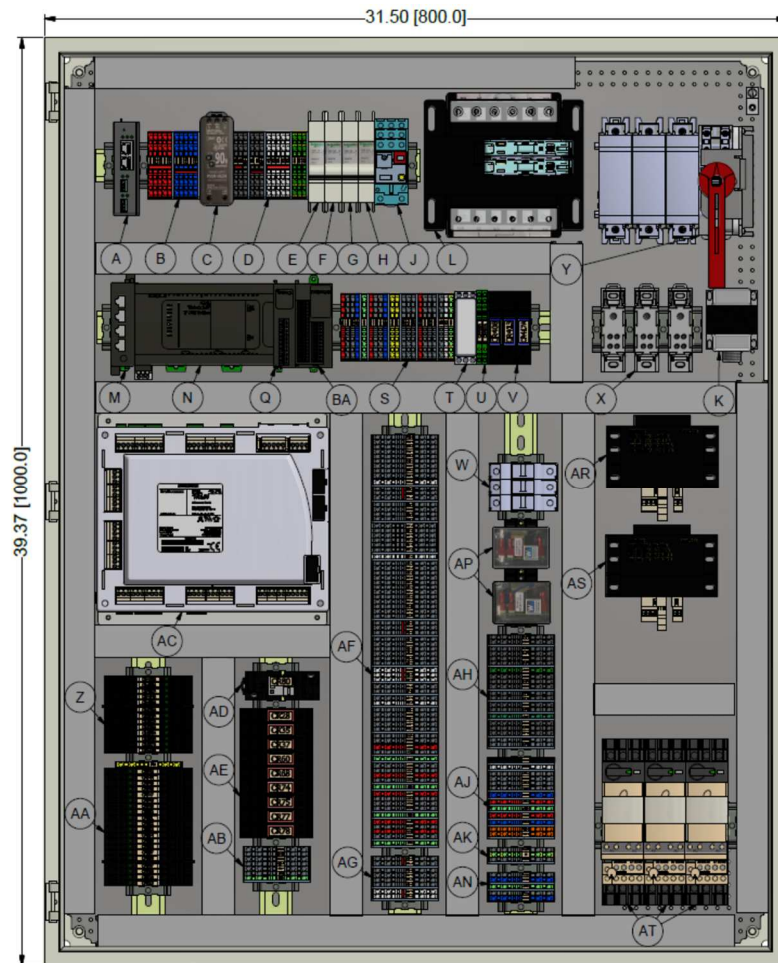

TS-CE226-xD6A-Bx32-4CAC

Options for Kit in Enclosure	(2) AGG5.210 Transformers Components (W, AK, AS)	Water Level Control Components (F, K, AJ)	Load Control Components (F, AH)	Draft Control Components (E, S, T, U, V)	PLC Output Components (Q, AN)	Additional Digital Inputs and Outputs (BA)	Warrick Relays (AP)	Motor Starters (AT)
TS-CE22x-xxxA-Bx2x-4xxx	X							
TS-CE2x3-xxxA-Bx2x-4xxx		X						
TS-CE2x4-xxxA-Bx2x-4xxx			X					
TS-CE2x4-xDxA-Bx2x-4xxx				X				
TS-CE2x4-xx3A-Bx2x-4xxx					X			
TS-CE2x4-xx6A-Bx2x-4xxx					X	X		
TS-CE2x4-xxxA-B32x-4xxx							X	
TS-CE2x4-xxxA-Bx2x-4CAC								X

TS-CExxx-xxxB-xxxx-XXXX

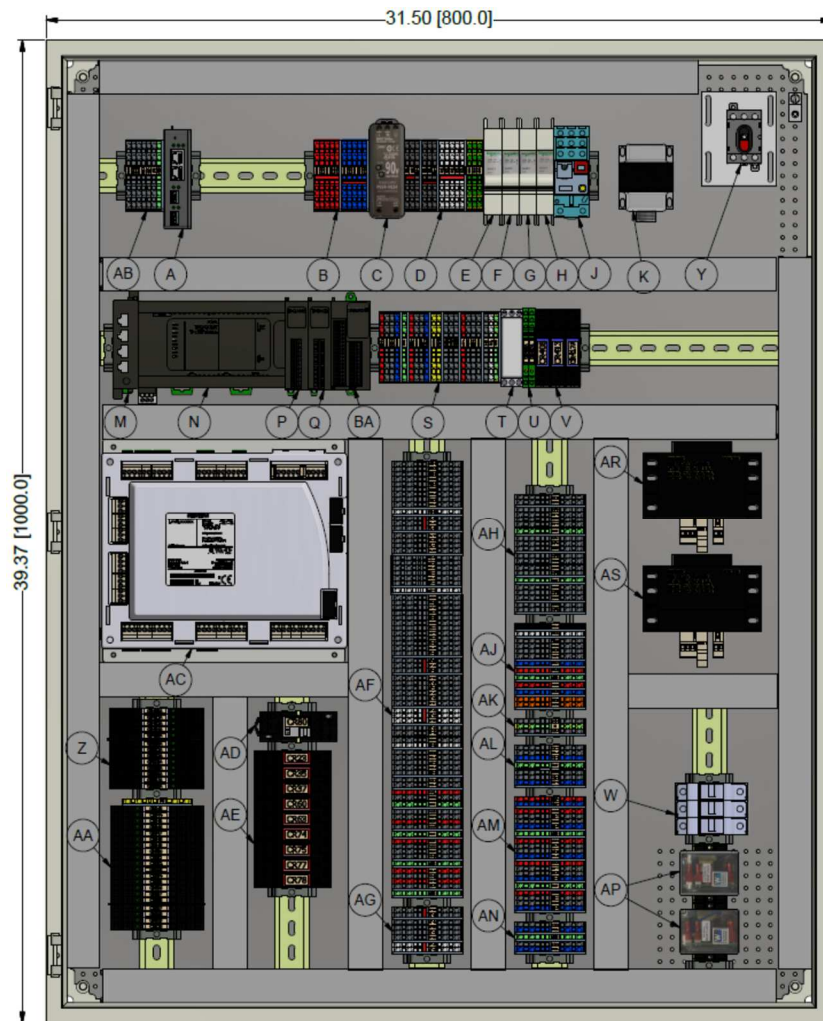

TS-CE226-xD6B-Bx32-XXXX

Options for Kit in Enclosure	(2) AGG5.210 Transformers Components (W, AK, AS)	Water Level Control Components (F, K, AJ)	Load Control Components (F, AH)	Draft Control Components (E, S, T, U, V)	PLC Output Components (Q, AN)	Additional Digital Inputs and Outputs (BA)	Warrick Relays (AP)
TS-CE22x-xxxB-Bx2x-XXXX	X						
TS-CE2x3-xxxB-Bx2x-XXXX		X					
TS-CE2x4-xxxB-Bx2x-XXXX			X				
TS-CE2x4-xDxB-Bx2x-XXXX				X			
TS-CE2x4-xx3B-Bx2x-XXXX					X		
TS-CE2x4-xx6B-Bx2x-XXXX					X	X	
TS-CE2x4-xxxB-B32x-XXXX							X

Notes:

- 32"x32" Enclosure used with (0-5) options
- 40"x32" Enclosure used with (6) or more options

TS-CExxx-xxxB-xxxx-4xxx

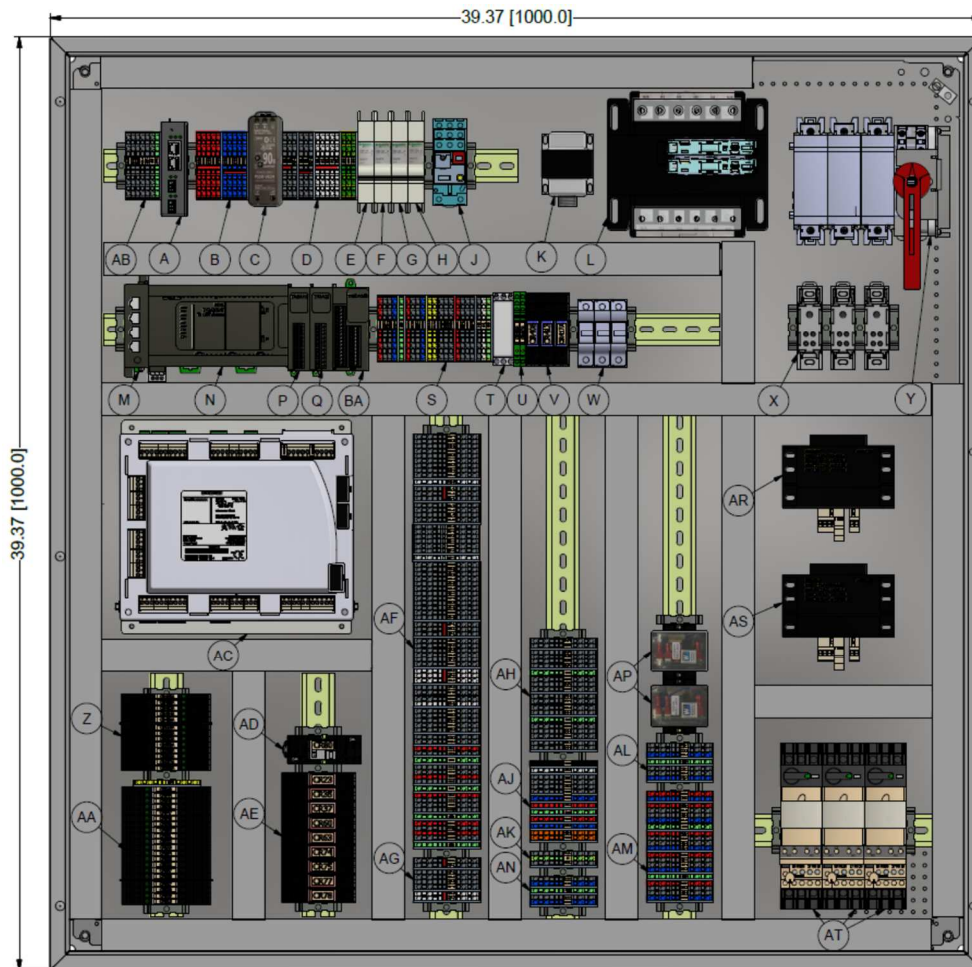

TS-CE226-xD6B-Bx32-4CAC

Options for Kit in Enclosure	(2) AGG5.210 Transformers Components (W, AK, AS)	Water Level Control Components (F, K, AJ)	Load Control Components (F, AH)	Draft Control Components (E, S, T, U, V)	PLC Output Components (Q, AN)	Additional Digital Inputs and Outputs (BA)	Warrick Relays (AP)	Motor Starters (AT)
TS-CE22x-xxxB-Bx2x-4xxx	X							
TS-CE2x3-xxxB-Bx2x-4xxx		X						
TS-CE2x4-xxxB-Bx2x-4xxx			X					
TS-CE2x4-xDxB-Bx2x-4xxx				X				
TS-CE2x4-xx3B-Bx2x-4xxx					X			
TS-CE2x4-xx6B-Bx2x-4xxx					X	X		
TS-CE2x4-xxxB-B32x-4xxx							X	
TS-CE2x4-xxxB-Bx2x-4CAC								X

TS-CE_{xxx-xxx}C-_{xxxx}-XXXX

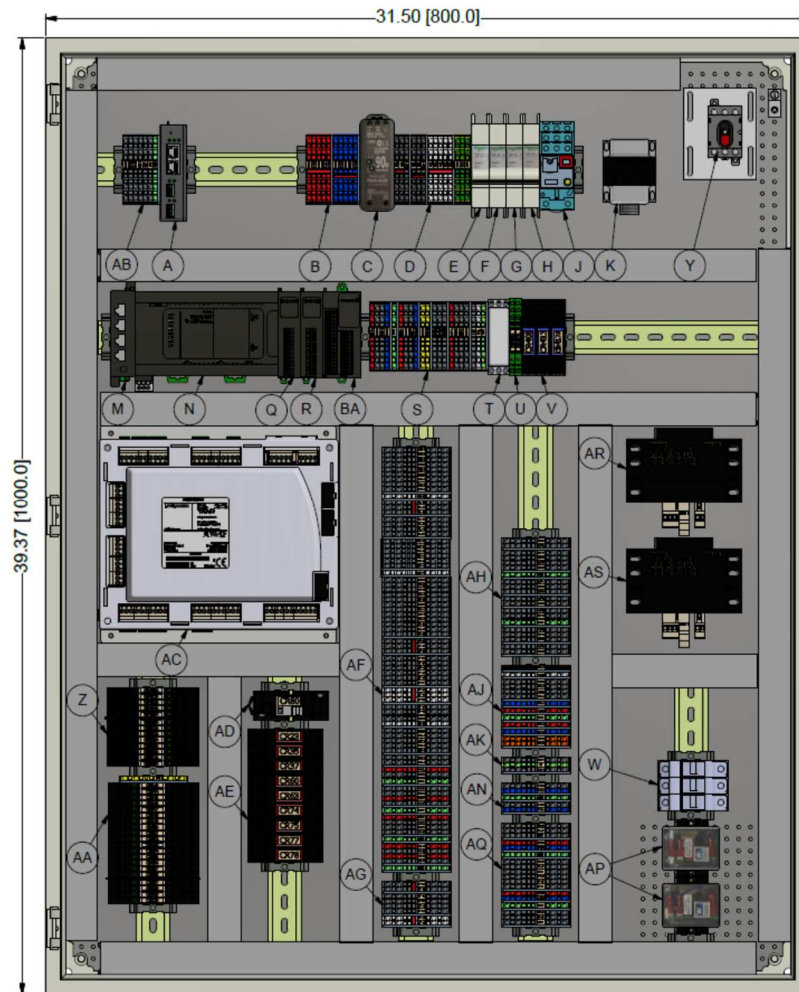

TS-CE226-xD6C-Bx32-XXXX

Options for Kit in Enclosure	(2) AGG5.210 Transformers Components (W, AK, AS)	Water Level Control Components (F, K, AJ)	Load Control Components (F, AH)	Draft Control Components (E, S, T, U, V)	PLC Output Components (Q, AN)	Additional Digital Inputs and Outputs (BA)	Warrick Relays (AP)
TS-CE22x- _{xxx} C-Bx2x-XXXX	X						
TS-CE2x3- _{xxx} C-Bx2x-XXXX		X					
TS-CE2x4- _{xxx} C-Bx2x-XXXX			X				
TS-CE2x4-xDx6C-Bx2x-XXXX				X			
TS-CE2x4-xx3C-Bx2x-XXXX					X		
TS-CE2x4-xx6C-Bx2x-XXXX					X	X	
TS-CE2x4- _{xxx} C-B32x-XXXX							X

Notes:
32"x32" Enclosure used with (0-5) options
40"x32" Enclosure used with (6) or more options

TS-CExxx-xxxC-xxxx-4xxx

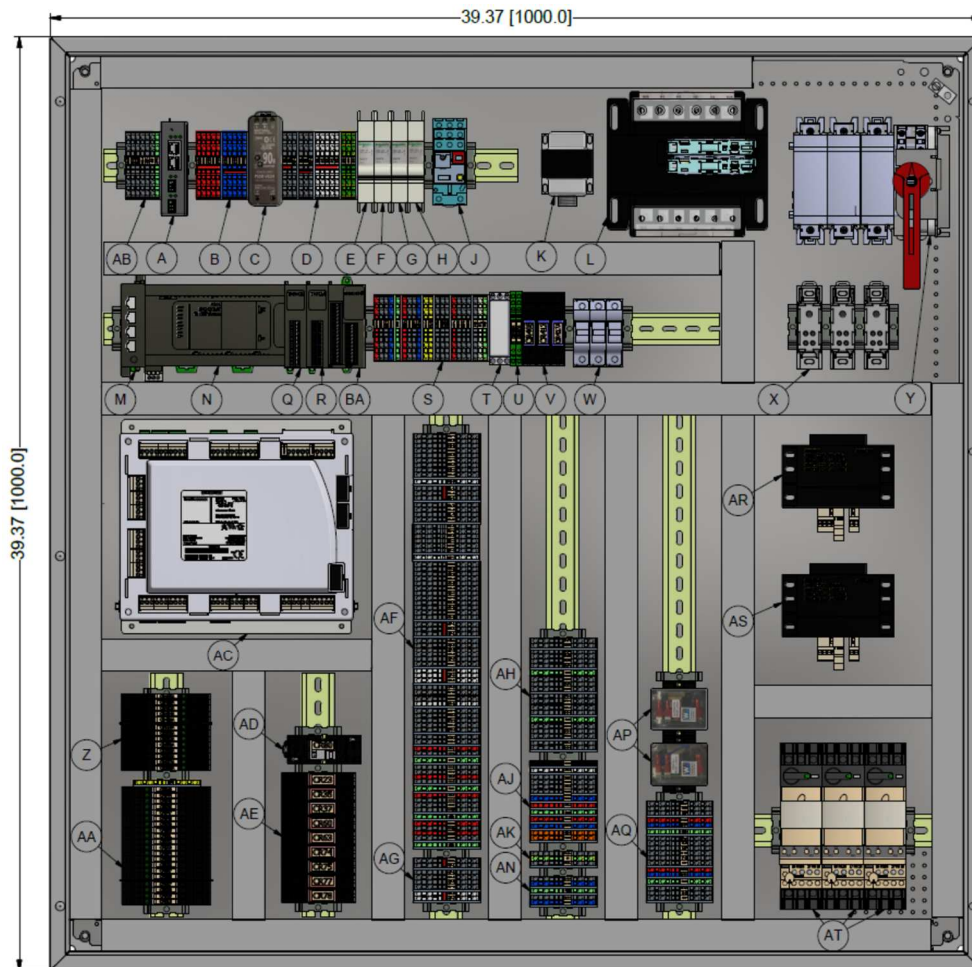

TS-CE226-xD6C-Bx32-4CAC

Options for Kit in Enclosure	(2) AGG5.210 Transformers Components (W, AK, AS)	Water Level Control Components (F, K, AJ)	Load Control Components (F, AH)	Draft Control Components (E, S, T, U, V)	PLC Output Components (Q, AN)	Additional Digital Inputs and Outputs (BA)	Warrick Relays (AP)	Motor Starters (AT)
TS-CE22x-xxxC-Bx2x-4xxx	X							
TS-CE2x3-xxxC-Bx2x-4xxx		X						
TS-CE2x4-xxxC-Bx2x-4xxx			X					
TS-CE2x4-xDxC-Bx2x-4xxx				X				
TS-CE2x4-xx3C-Bx2x-4xxx					X			
TS-CE2x4-xx6C-Bx2x-4xxx					X	X		
TS-CE2x4-xxxC-B32x-4xxx							X	
TS-CE2x4-xxxC-Bx2x-4CAC								X

TS-CExxx-xxxD-xxxx-XXXX

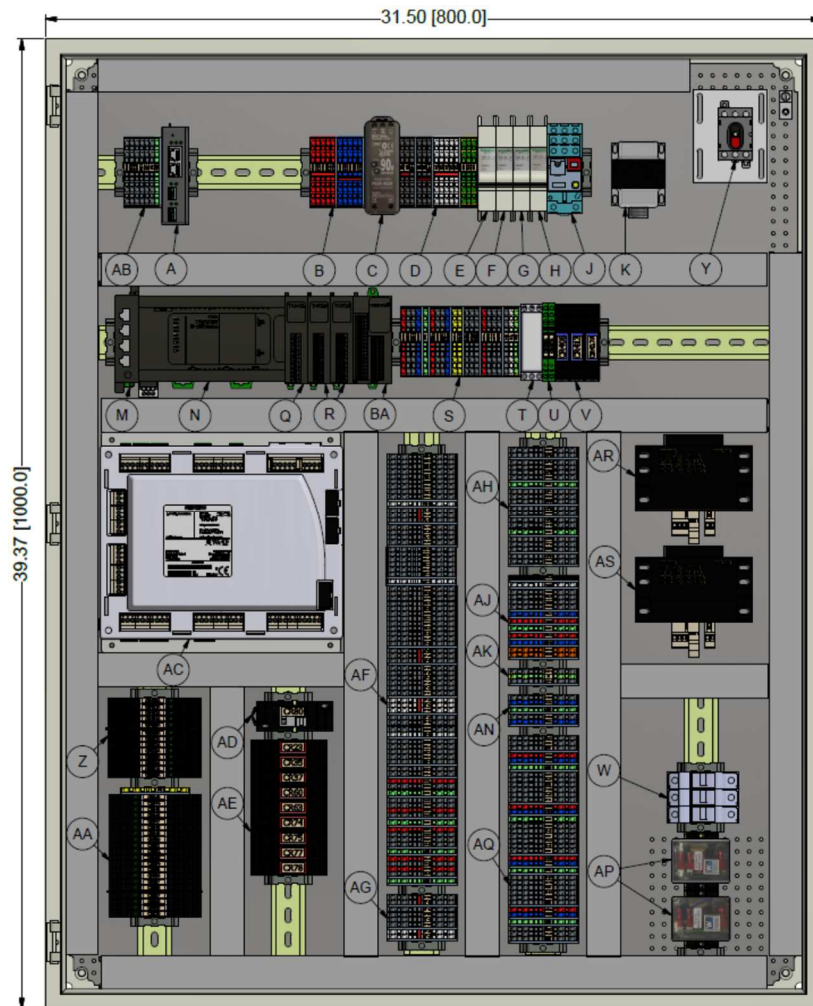

TS-CE226-xD6D-Bx32-XXXX

Options for Kit in Enclosure	(2) AGG5.210 Transformers Components (W, AK, AS)	Water Level Control Components (F, K, AJ)	Load Control Components (F, AH)	Draft Control Components (E, S, T, U, V)	PLC Output Components (Q, AN)	Additional Digital Inputs and Outputs (BA)	Warrick Relays (AP)
TS-CE22x-xxxD-Bx2x-XXXX	X						
TS-CE2x3-xxxD-Bx2x-XXXX		X					
TS-CE2x4-xxxD-Bx2x-XXXX			X				
TS-CE2x4-xDxD-Bx2x-XXXX				X			
TS-CE2x4-xx3D-Bx2x-XXXX					X		
TS-CE2x4-xx6D-Bx2x-XXXX					X	X	
TS-CE2x4-xxxD-B32x-XXXX							X

Notes:

- 32"x32" Enclosure used with (0-4) options
- 40"x32" Enclosure used with (5) or more options

TS-CExxx-xxxD-xxxx-4xxx

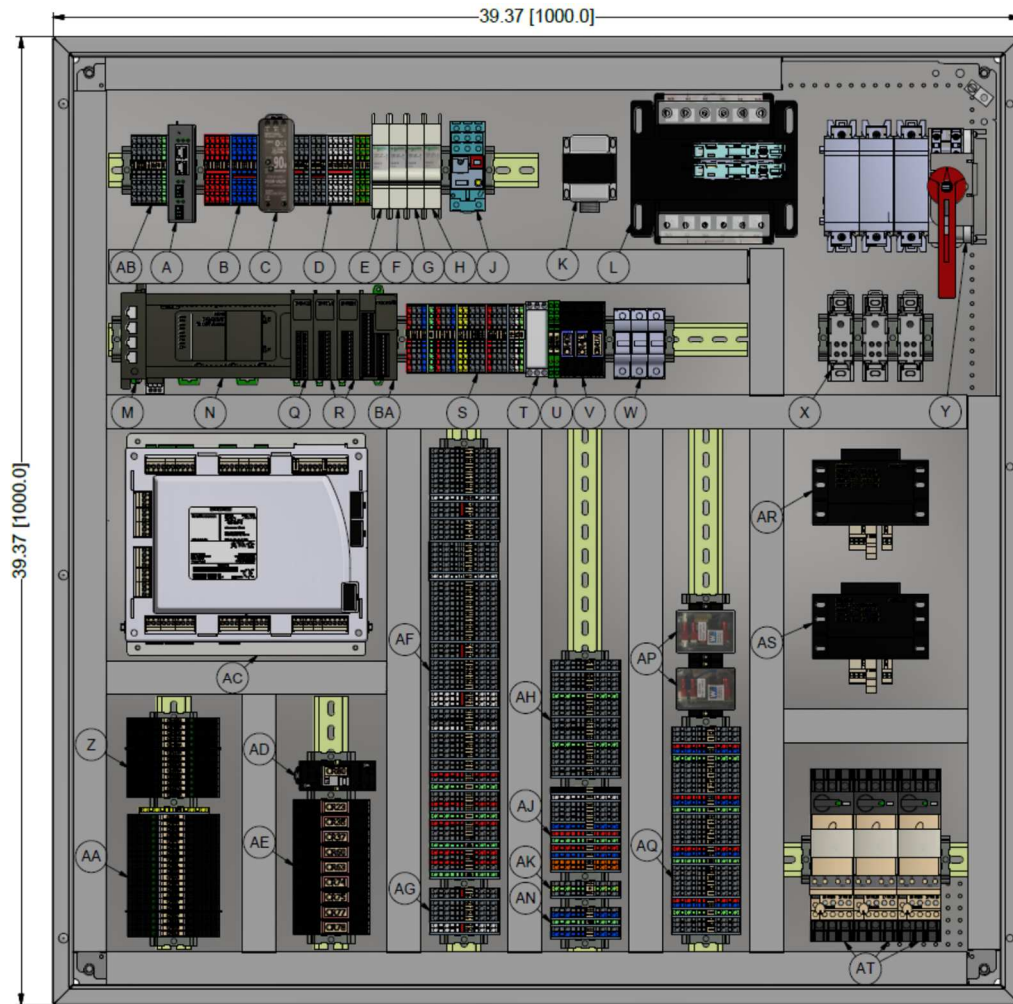

TS-CE226-xD6D-Bx32-4CAC

Options for Kit in Enclosure	(2) AGG5.210 Transformers Components (W, AK, AS)	Water Level Control Components (F, K, AJ)	Load Control Components (F, AH)	Draft Control Components (E, S, T, U, V)	PLC Output Components (Q, AN)	Additional Digital Inputs and Outputs (BA)	Warrick Relays (AP)	Motor Starters (AT)
TS-CE22x-xxxD-Bx2x-4xxx	X							
TS-CE2x3-xxxD-Bx2x-4xxx		X						
TS-CE2x4-xxxD-Bx2x-4xxx			X					
TS-CE2x4-xDxD-Bx2x-4xxx				X				
TS-CE2x4-xx3D-Bx2x-4xxx					X			
TS-CE2x4-xx6D-Bx2x-4xxx					X	X		
TS-CE2x4-xxxD-B32x-4xxx							X	
TS-CE2x4-xxxD-Bx2x-4CAC								X

Notes:

40"x32" Enclosure used with (0-6) options

40"x40" Enclosure used with (7) options

TS-CExxx-xxxE-xxxx-XXXX

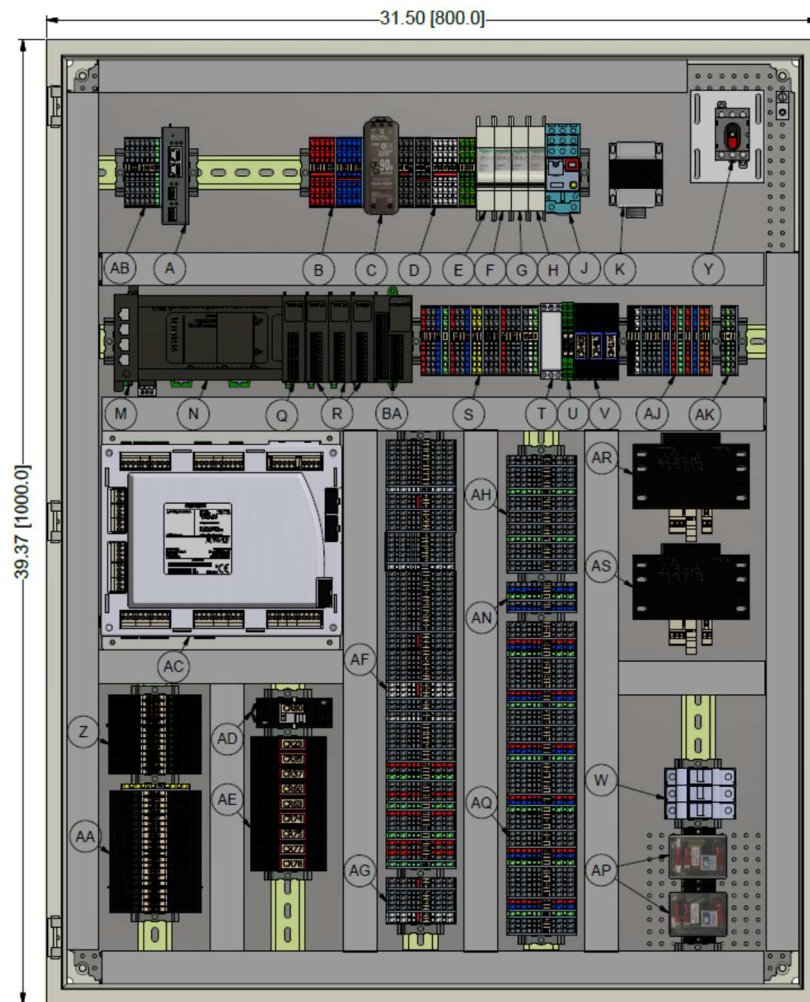

TS-CE226-xD6E-Bx32-XXXX

Options for Kit in Enclosure	(2) AGG5.210 Transformers Components (W, AK, AS)	Water Level Control Components (F, K, AJ)	Load Control Components (F, AH)	Draft Control Components (E, S, T, U, V)	PLC Output Components (Q, AN)	Additional Digital Inputs and Outputs (BA)	Warrick Relays (AP)
TS-CE22x-xxxE-Bx2x-XXXX	X						
TS-CE2x3-xxxE-Bx2x-XXXX		X					
TS-CE2x4-xxxE-Bx2x-XXXX			X				
TS-CE2x4-xDxE-Bx2x-XXXX				X			
TS-CE2x4-xx3E-Bx2x-XXXX					X		
TS-CE2x4-xx6E-Bx2x-XXXX					X	X	
TS-CE2x4-xxxE-B32x-XXXX							X

Notes:

32"x32" Enclosure used with (0-3) options

40"x32" Enclosure used with (4) or more options

TS-CExxx-xxxE-xxxx-4xxx

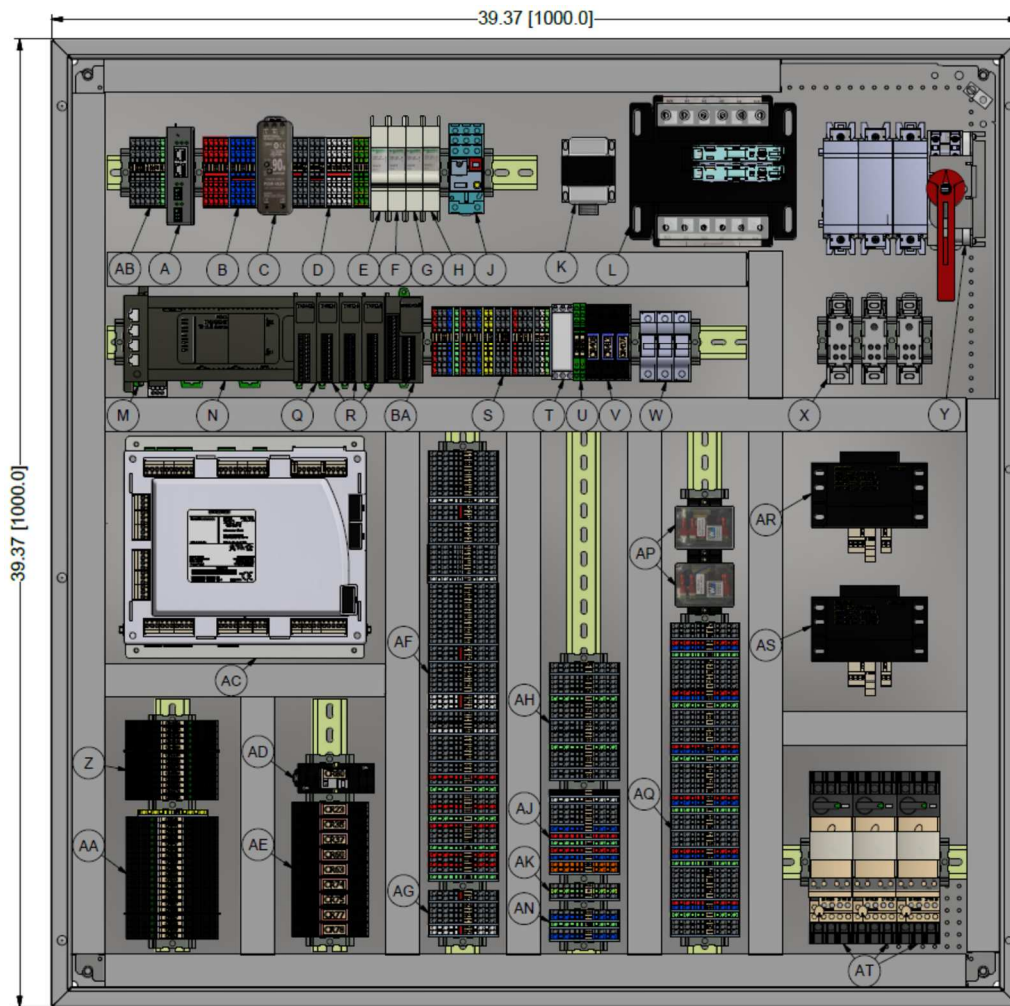

TS-CE226-xD6E-Bx32-4CAC

Options for Kit in Enclosure	(2) AGG5.210 Transformers Components (W, AK, AS)	Water Level Control Components (F, K, AJ)	Load Control Components (F, AH)	Draft Control Components (E, S, T, U, V)	PLC Output Components (Q, AN)	Additional Digital Inputs and Outputs (BA)	Warrick Relays (AP)	Motor Starters (AT)
TS-CE22x-xxxE-Bx2x-4xxx	X							
TS-CE2x3-xxxE-Bx2x-4xxx		X						
TS-CE2x4-xxxE-Bx2x-4xxx			X					
TS-CE2x4-xDxE-Bx2x-4xxx				X				
TS-CE2x4-xx3E-Bx2x-4xxx					X			
TS-CE2x4-xx6E-Bx2x-4xxx					X	X		
TS-CE2x4-xxxE-B32x-4xxx							X	
TS-CE2x4-xxxE-Bx2x-4CAC								X

Notes:

- 40"x32" Enclosure used with (0-5) options
- 40"x40" Enclosure used with (6) or more options

TS-CE_{xxx}-_{xxx}F-_{xxxx}-XXXX

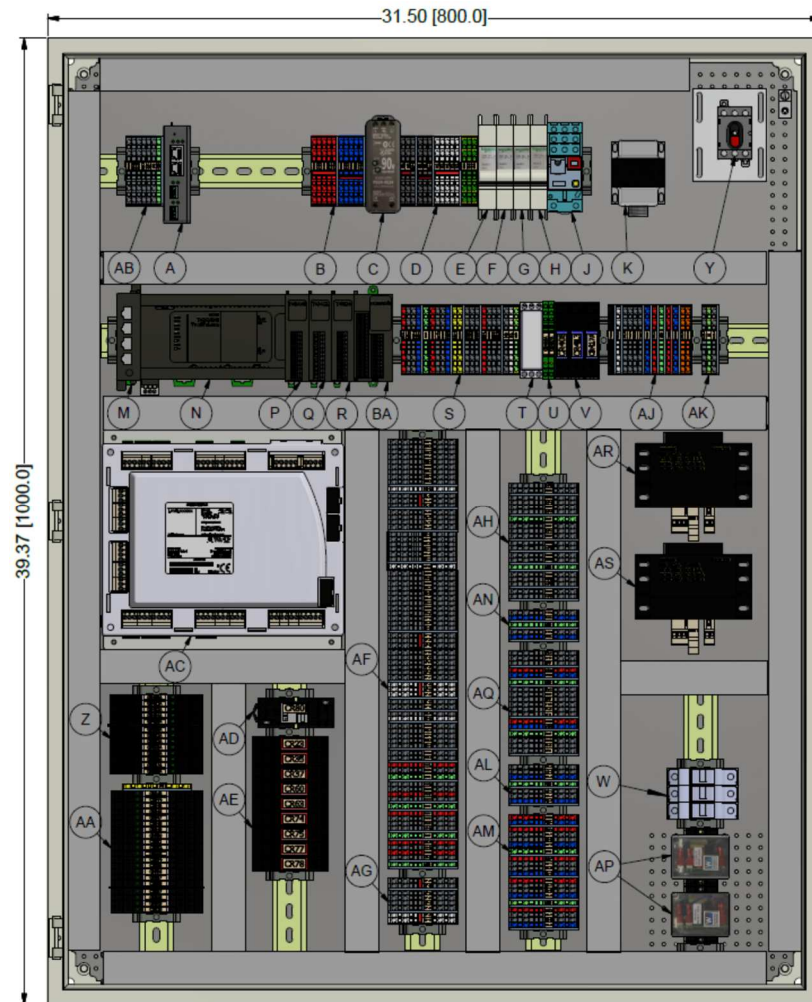

TS-CE226-xD6F-Bx32-XXXX

Options for Kit in Enclosure	(2) AGG5.210 Transformers Components (W, AK, AS)	Water Level Control Components (F, K, AJ)	Load Control Components (F, AH)	Draft Control Components (E, S, T, U, V)	PLC Output Components (Q, AN)	Additional Digital Inputs and Outputs (BA)	Warrick Relays (AP)
TS-CE22x- _{xxx} F-Bx2x-XXXX	X						
TS-CE2x3- _{xxx} F-Bx2x-XXXX		X					
TS-CE2x4- _{xxx} F-Bx2x-XXXX			X				
TS-CE2x4-xD _x F-Bx2x-XXXX				X			
TS-CE2x4-xx3F-Bx2x-XXXX					X		
TS-CE2x4-xx6F-Bx2x-XXXX						X	
TS-CE2x4- _{xxx} F-B32x-XXXX							X

Notes:

32"x32" Enclosure used with (0-3) options

40"x32" Enclosure used with (4) or more options

TS-CExxx-xxxF-xxxx-4xxx

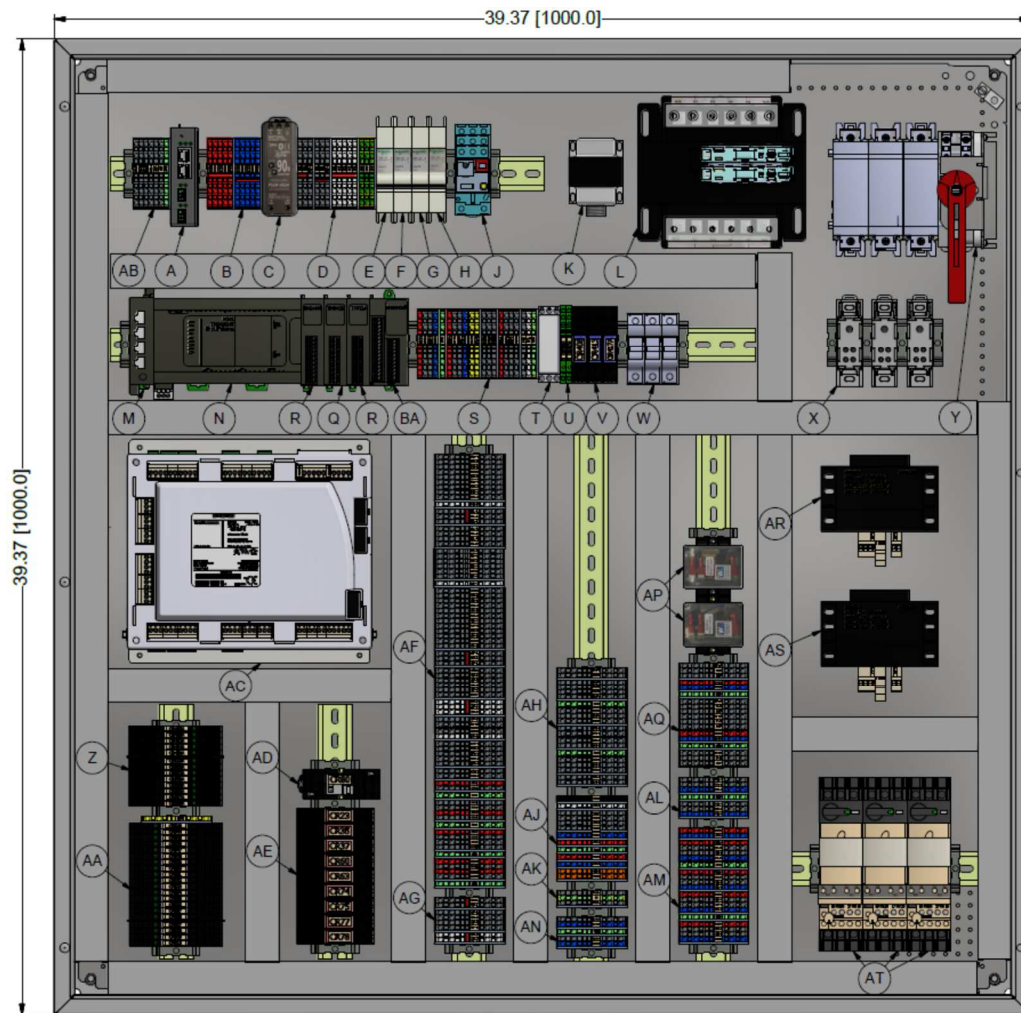

TS-CE226-xD6F-Bx32-4CAC

Options for Kit in Enclosure	(2) AGG5.210 Transformers Components (W, AK, AS)	Water Level Control Components (F, K, AJ)	Load Control Components (F, AH)	Draft Control Components (E, S, T, U, V)	PLC Output Components (Q, AN)	Additional Digital Inputs and Outputs (BA)	Warrick Relays (AP)	Motor Starters (AT)
TS-CE22x-xxxF-Bx2x-4xxx	X							
TS-CE2x3-xxxF-Bx2x-4xxx		X						
TS-CE2x4-xxxF-Bx2x-4xxx			X					
TS-CE2x4-xDx6F-Bx2x-4xxx				X				
TS-CE2x4-xx3F-Bx2x-4xxx					X			
TS-CE2x4-xx6F-Bx2x-4xxx					X	X		
TS-CE2x4-xxxF-B32x-4xxx							X	
TS-CE2x4-xxxF-Bx2x-4CAC								X

Notes:

40"x32" Enclosure used with (0-5) options

40"x40" Enclosure used with (6) or more options

TS-CExxx-xxxG-xxxx-XXXX

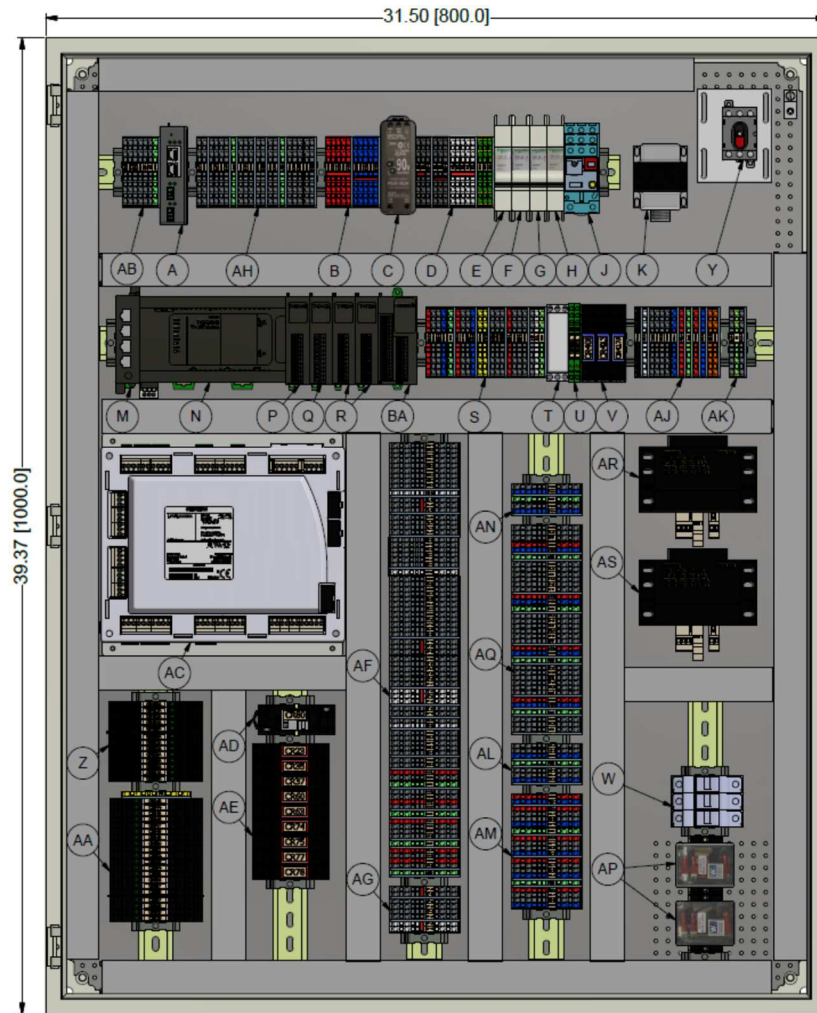

TS-CE226-xD6G-Bx32-XXXX

Options for Kit in Enclosure	(2) AGG5.210 Transformers Components (W, AK, AS)	Water Level Control Components (F, K, AJ)	Load Control Components (F, AH)	Draft Control Components (E, S, T, U, V)	PLC Output Components (Q, AN)	Additional Digital Inputs and Outputs (BA)	Warrick Relays (AP)
TS-CE22x-xxxG-Bx2x-XXXX	X						
TS-CE2x3-xxxG-Bx2x-XXXX		X					
TS-CE2x4-xxxG-Bx2x-XXXX			X				
TS-CE2x4-xDxG-Bx2x-XXXX				X			
TS-CE2x4-xx3G-Bx2x-XXXX					X		
TS-CE2x4-xx6G-Bx2x-XXXX					X	X	
TS-CE2x4-xxxG-B32x-XXXX							X

Notes:

- 32"x32" Enclosure used with (0-2) options
- 40"x32" Enclosure used with (3) or more options

TS-CExxx-xxxG-xxxx-4xxx

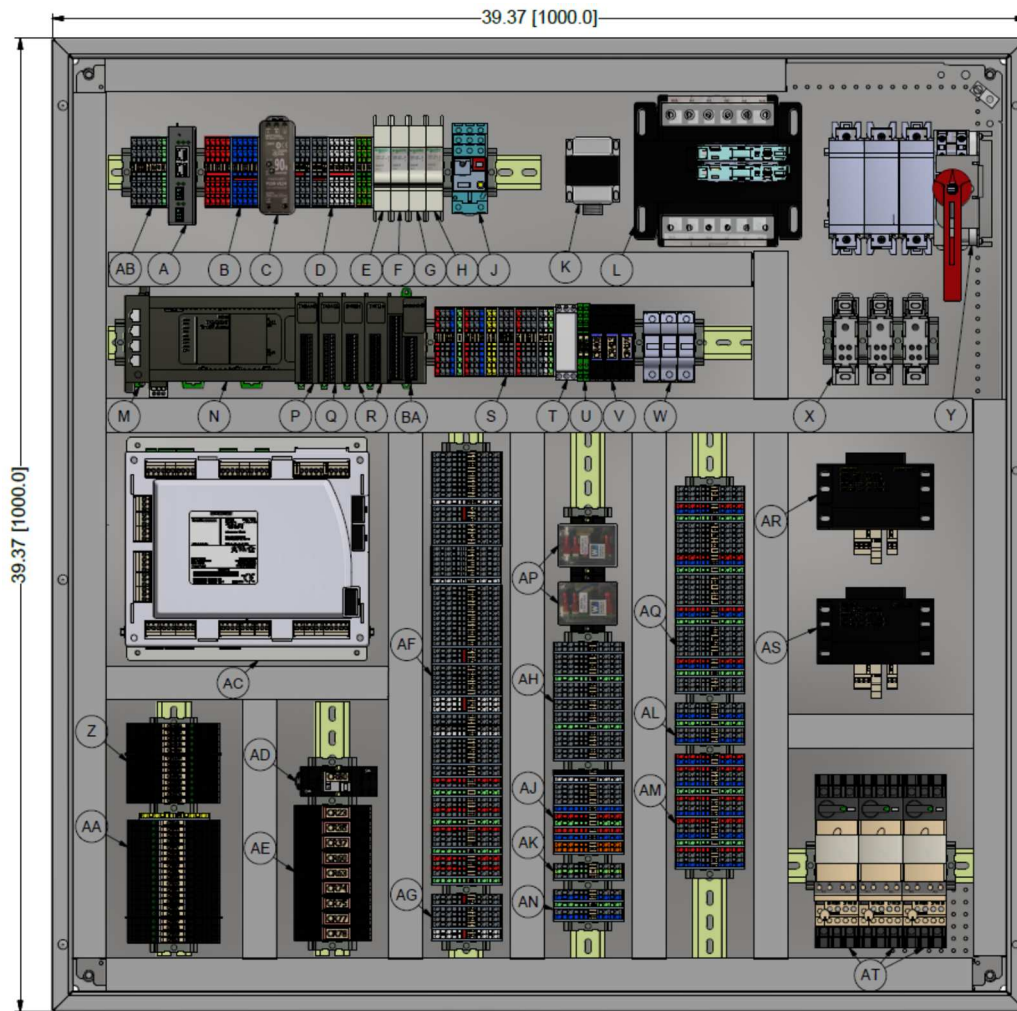

TS-CE226-xD6G-Bx32-4CAC

Options for Kit in Enclosure	(2) AGG5.210 Transformers Components (W, AK, AS)	Water Level Control Components (F, K, AJ)	Load Control Components (F, AH)	Draft Control Components (E, S, T, U, V)	PLC Output Components (Q, AN)	Additional Digital Inputs and Outputs (BA)	Warrick Relays (AP)	Motor Starters (AT)
TS-CE22x-xxxG-Bx2x-4xxx	X							
TS-CE2x3-xxxG-Bx2x-4xxx		X						
TS-CE2x4-xxxG-Bx2x-4xxx			X					
TS-CE2x4-xDxG-Bx2x-4xxx				X				
TS-CE2x4-xx3G-Bx2x-4xxx					X			
TS-CE2x4-xx6G-Bx2x-4xxx					X	X		
TS-CE2x4-xxxG-B32x-4xxx							X	
TS-CE2x4-xxxG-Bx2x-4CAC								X

Notes:

- 40"x32" Enclosure used with (0-4) options
- 40"x40" Enclosure used with (5) or more options

TS-CExxx-xxxH-xxxx-XXXX

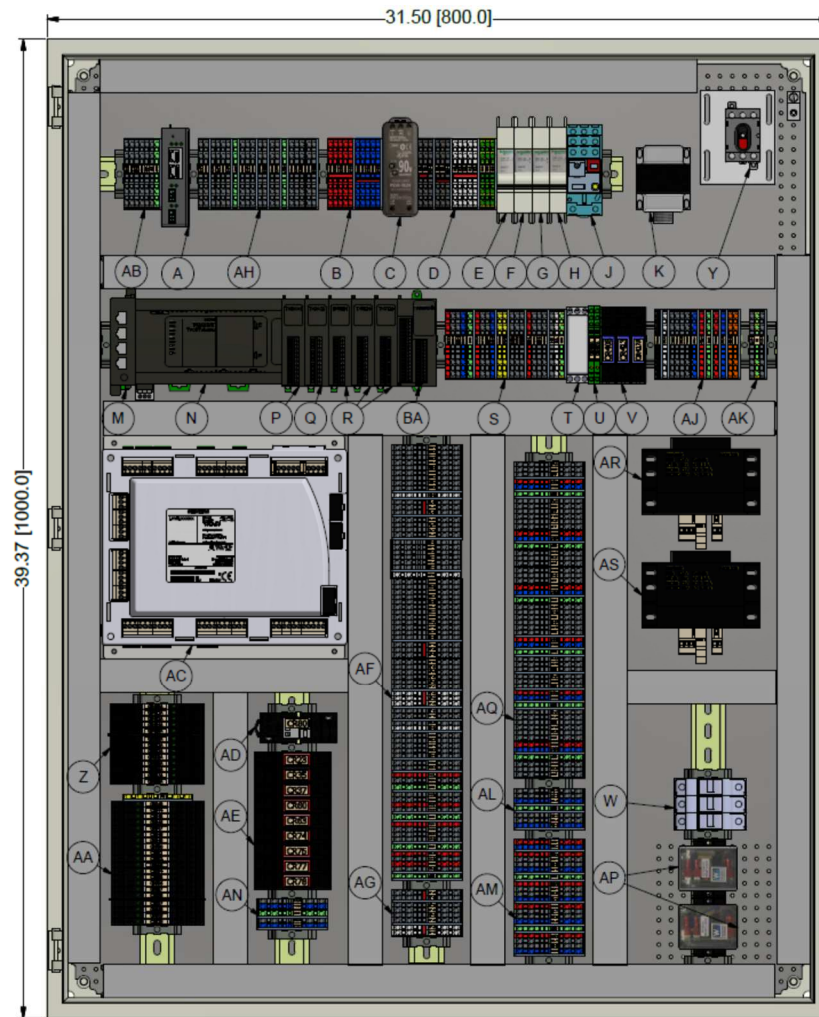

TS-CE226-xD6H-Bx32-XXXX

Options for Kit in Enclosure	(2) AGG5.210 Transformers Components (W, AK, AS)	Water Level Control Components (F, K, AJ)	Load Control Components (F, AH)	Draft Control Components (E, S, T, U, V)	PLC Output Components (Q, AN)	Additional Digital Inputs and Outputs (BA)	Warrick Relays (AP)
TS-CE22x-xxxH-Bx2x-XXXX	X						
TS-CE2x3-xxxH-Bx2x-XXXX		X					
TS-CE2x4-xxxH-Bx2x-XXXX			X				
TS-CE2x4-xDxH-Bx2x-XXXX				X			
TS-CE2x4-xx3H-Bx2x-XXXX					X		
TS-CE2x4-xx6H-Bx2x-XXXX					X	X	
TS-CE2x4-xxxH-B32x-XXXX							X

Notes:

- 32"x32" Enclosure used with (0-1) options
- 40"x32" Enclosure used with (2) or more options

TS-CExxx-xxxH-xxxx-4xxx

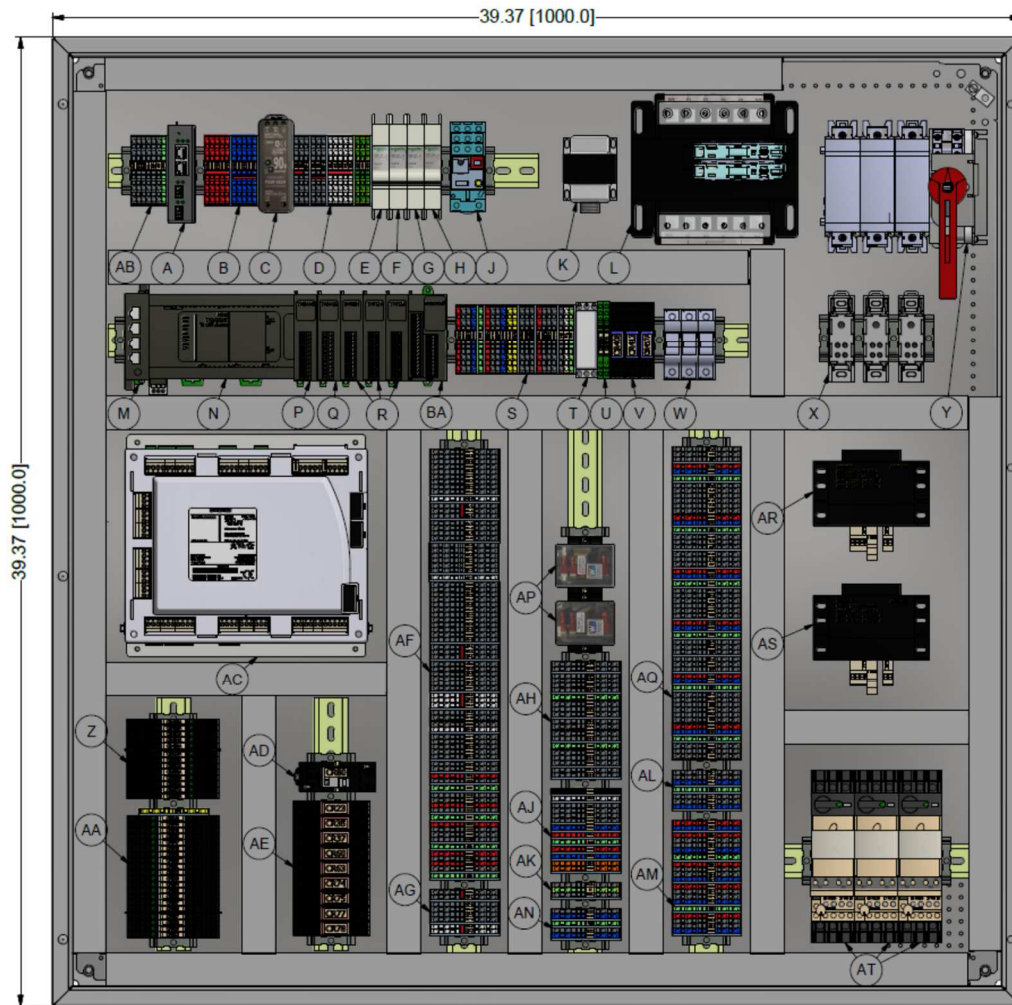

TS-CE226-xD3H-Bx32-4CAC

Options for Kit in Enclosure	(2) AGG5.210 Transformers Components (W, AK, AS)	Water Level Control Components (F, K, AJ)	Load Control Components (F, AH)	Draft Control Components (E, S, T, U, V)	PLC Output Components (Q, AN)	Additional Digital Inputs and Outputs (BA)	Warrick Relays (AP)	Motor Starters (AT)
TS-CE22x-xxxH-Bx2x-4xxx	X							
TS-CE2x3-xxxH-Bx2x-4xxx		X						
TS-CE2x4-xxxH-Bx2x-4xxx			X					
TS-CE2x4-xDxH-Bx2x-4xxx				X				
TS-CE2x4-xx3H-Bx2x-4xxx					X			
TS-CE2x4-xx6H-Bx2x-4xxx					X	X		
TS-CE2x4-xxxH-B32x-4xxx							X	
TS-CE2x4-xxxH-Bx2x-4CAC								X

Notes:

40"x32" Enclosure used with (0-3) options

40"x40" Enclosure used with (4) or more options

24" X 24" X 10" Enclosure Dimensions

TS-CExx(3/4)-2xxx-x1x2-xxxx

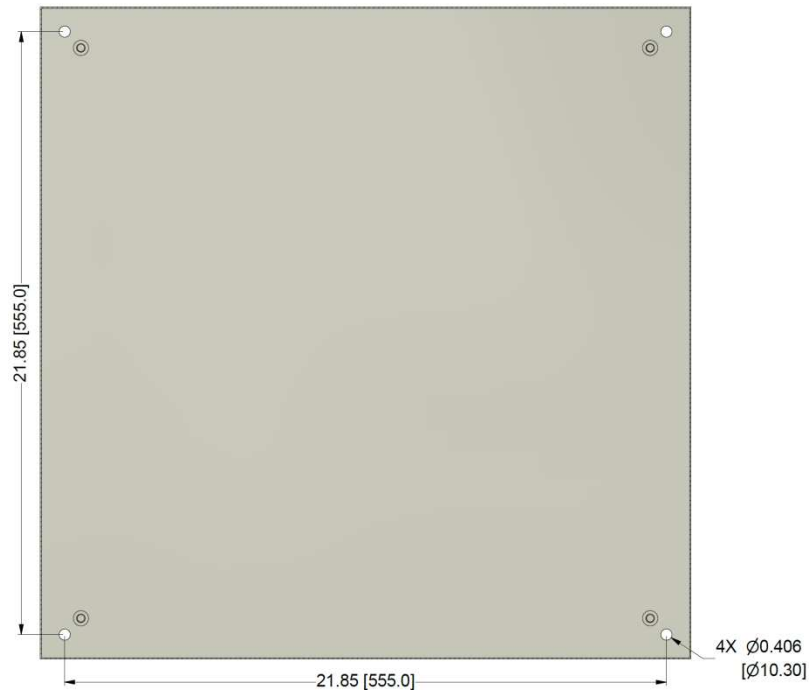
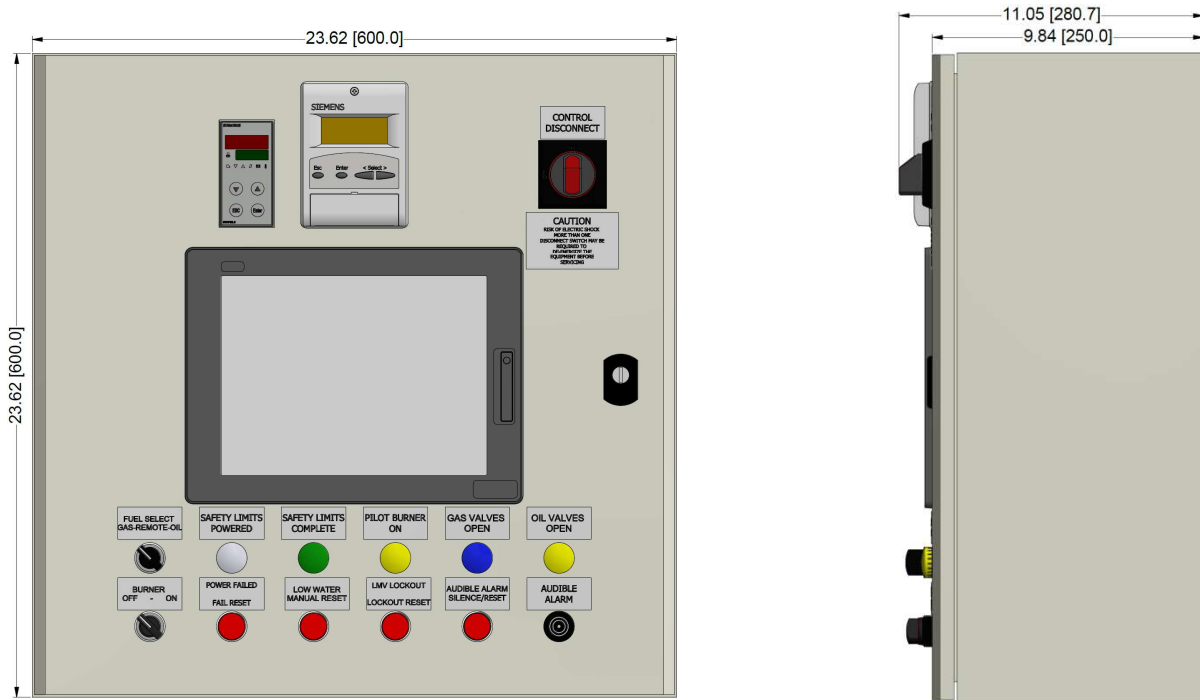

TS-CExx(3/4)-6xxx-x2x2-xxxx

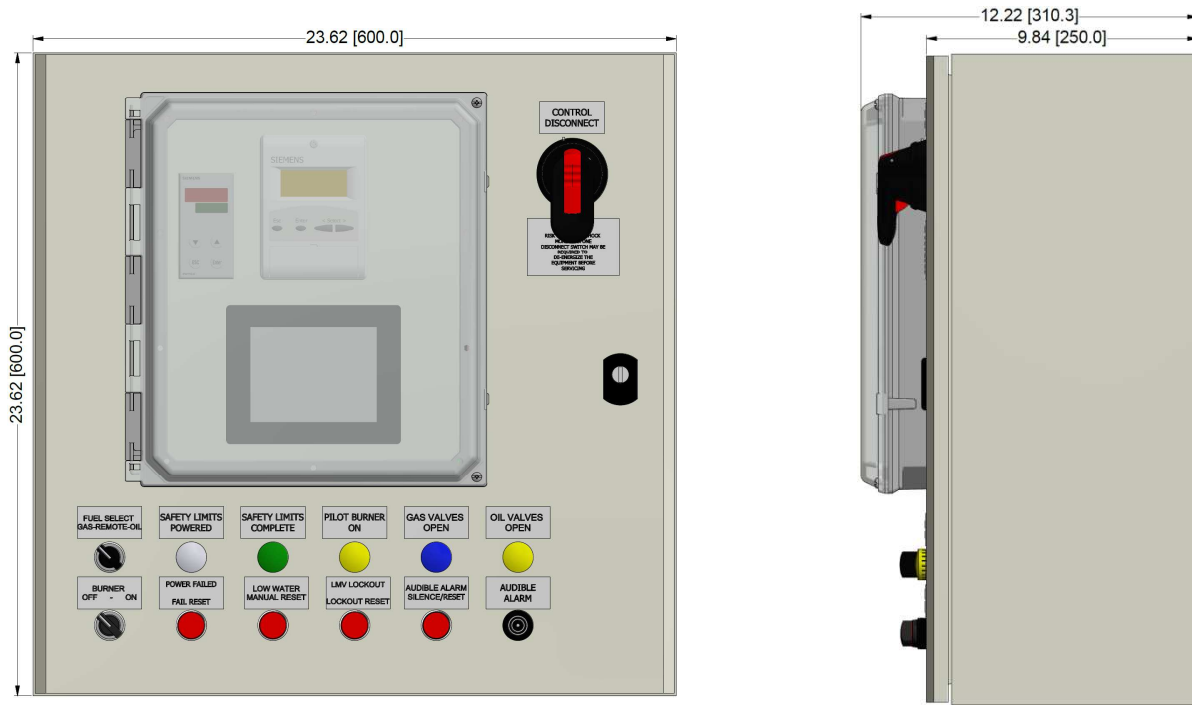

32" X 32" X 10" Enclosure Dimensions

TS-CExx(3/4)-5xxx-x1x2-xxxx

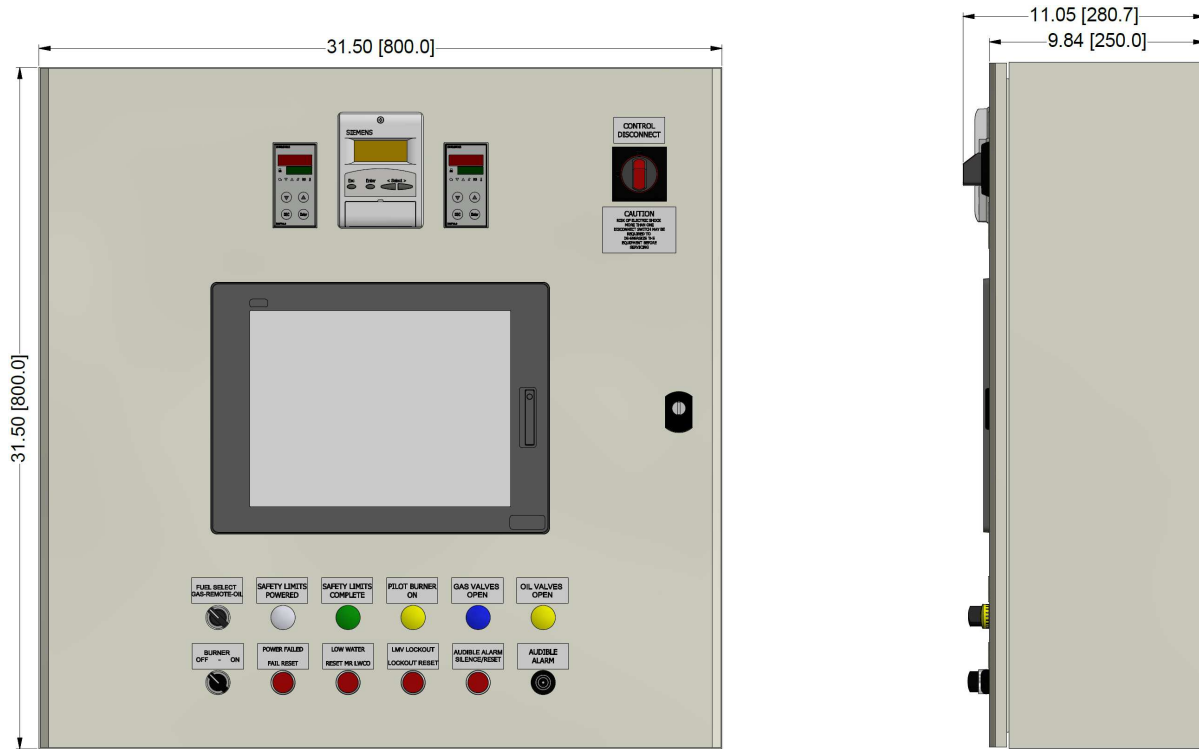

TS-CExx(3/4)-2xxx-x2x2-xxxx

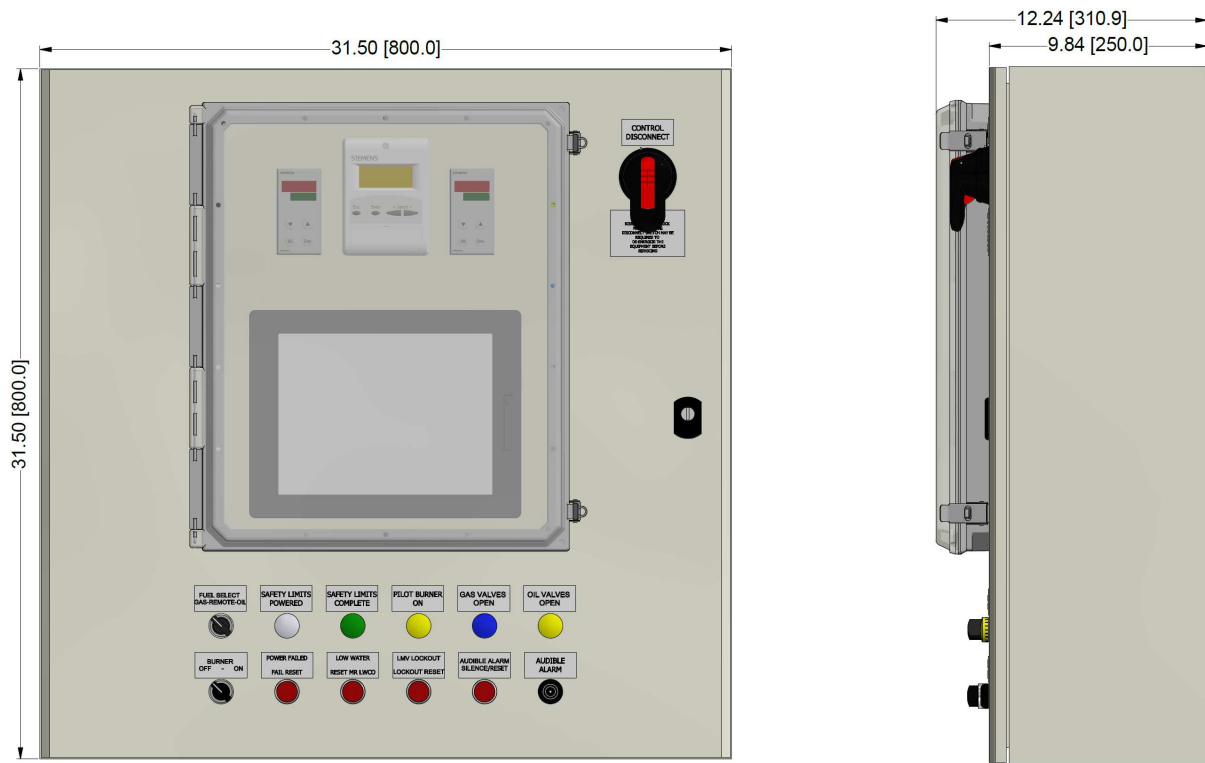

40" X 32" X 10" Enclosure Dimensions

TS-CExx(3/4)-5xxx-x1x2-xxxx

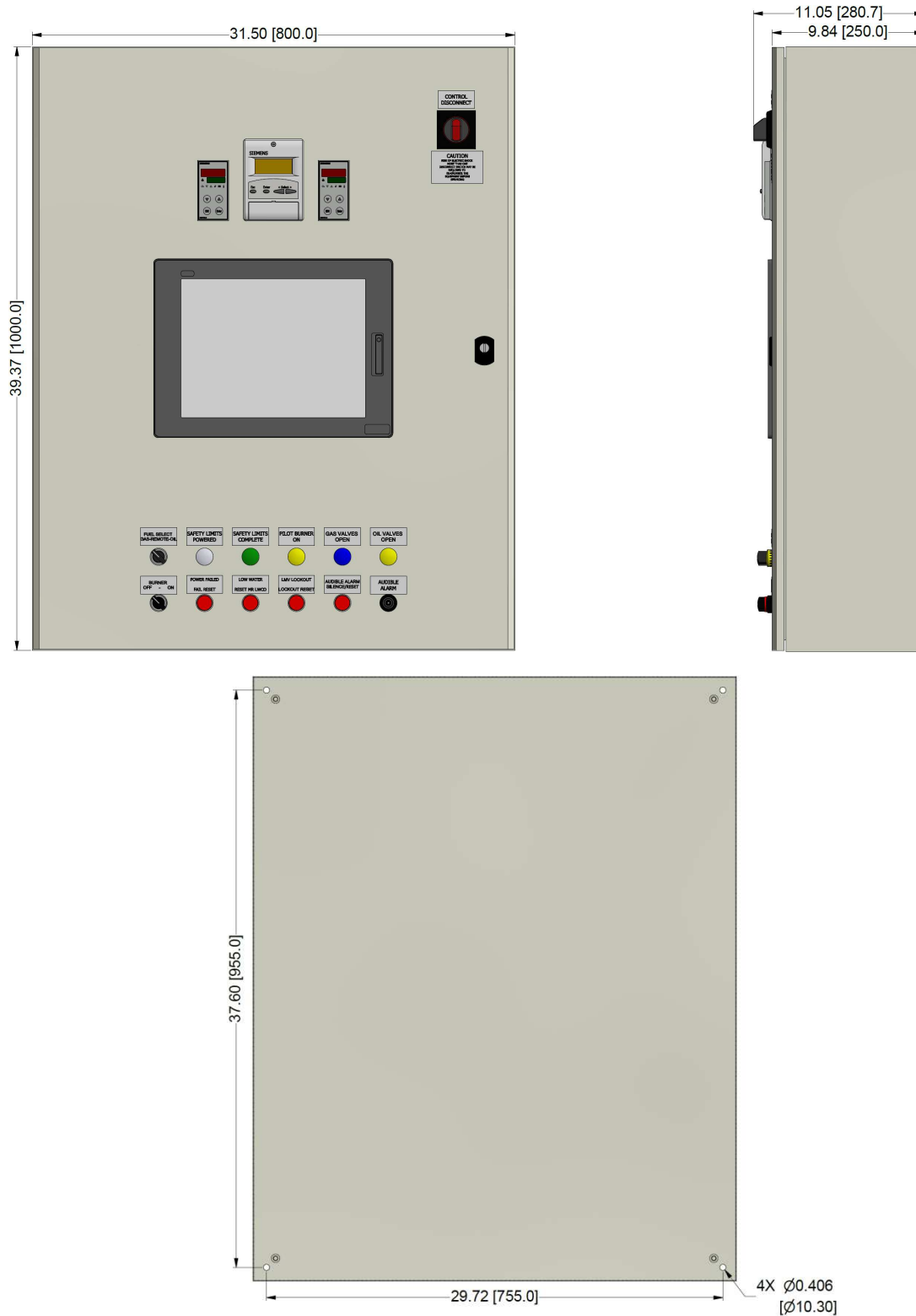

TS-CExx(3/4)-2xxx-x2x2-xxxx

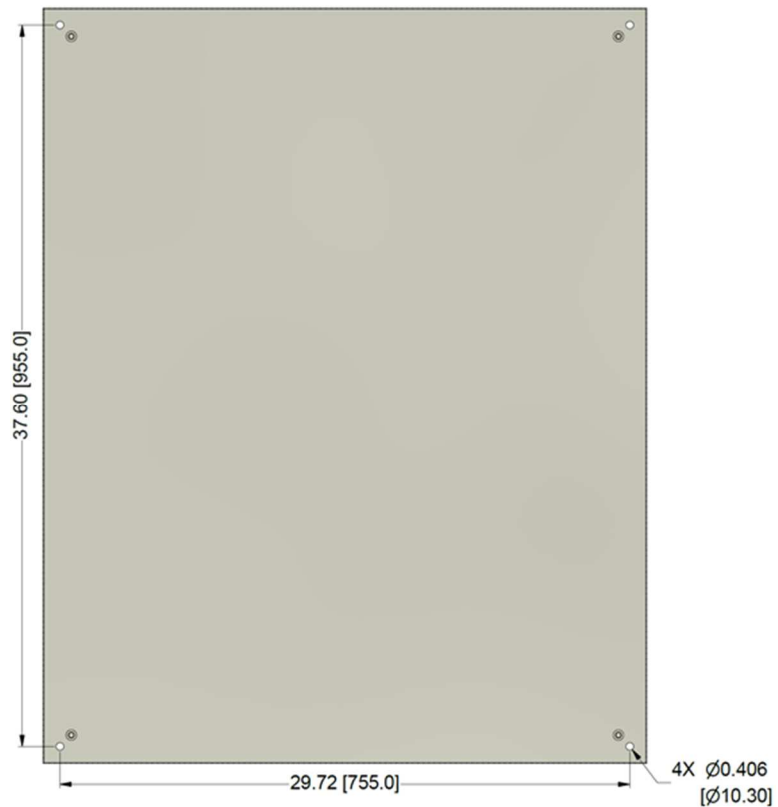
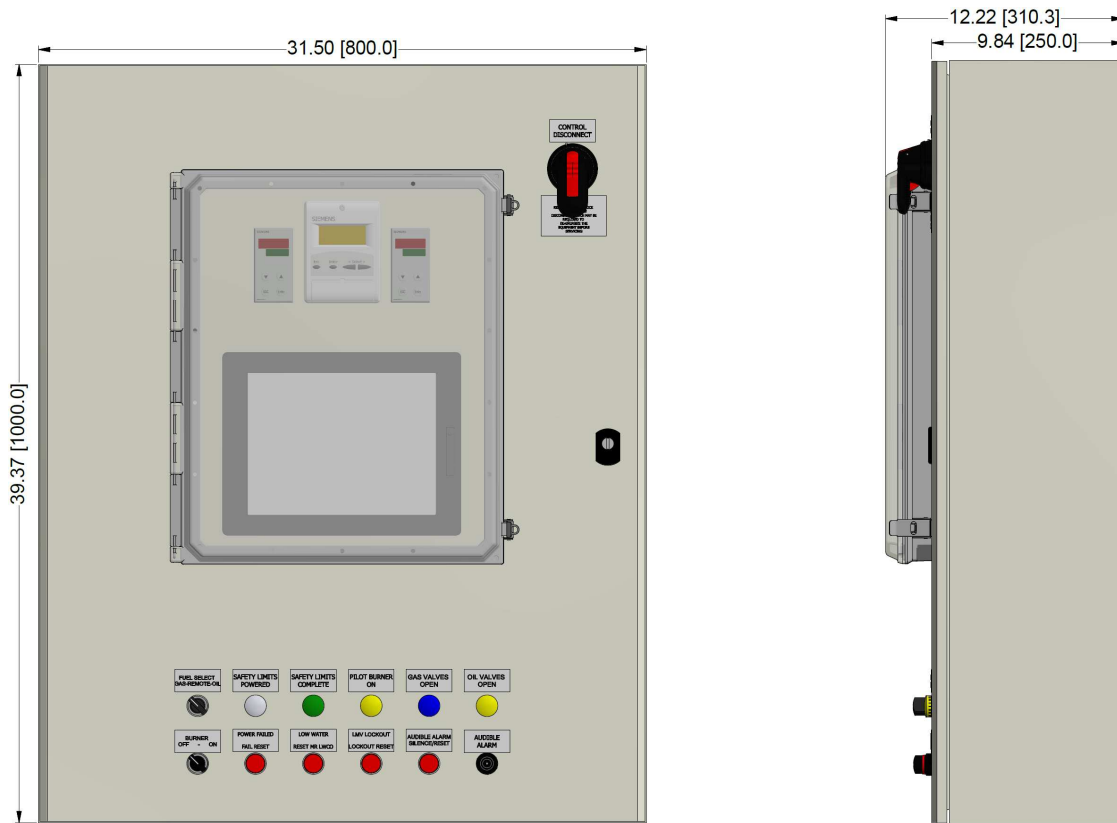

40" X 40" X 12" Enclosure Dimensions

TS-CExx(3/4)-5xxx-x1x2-xxxx

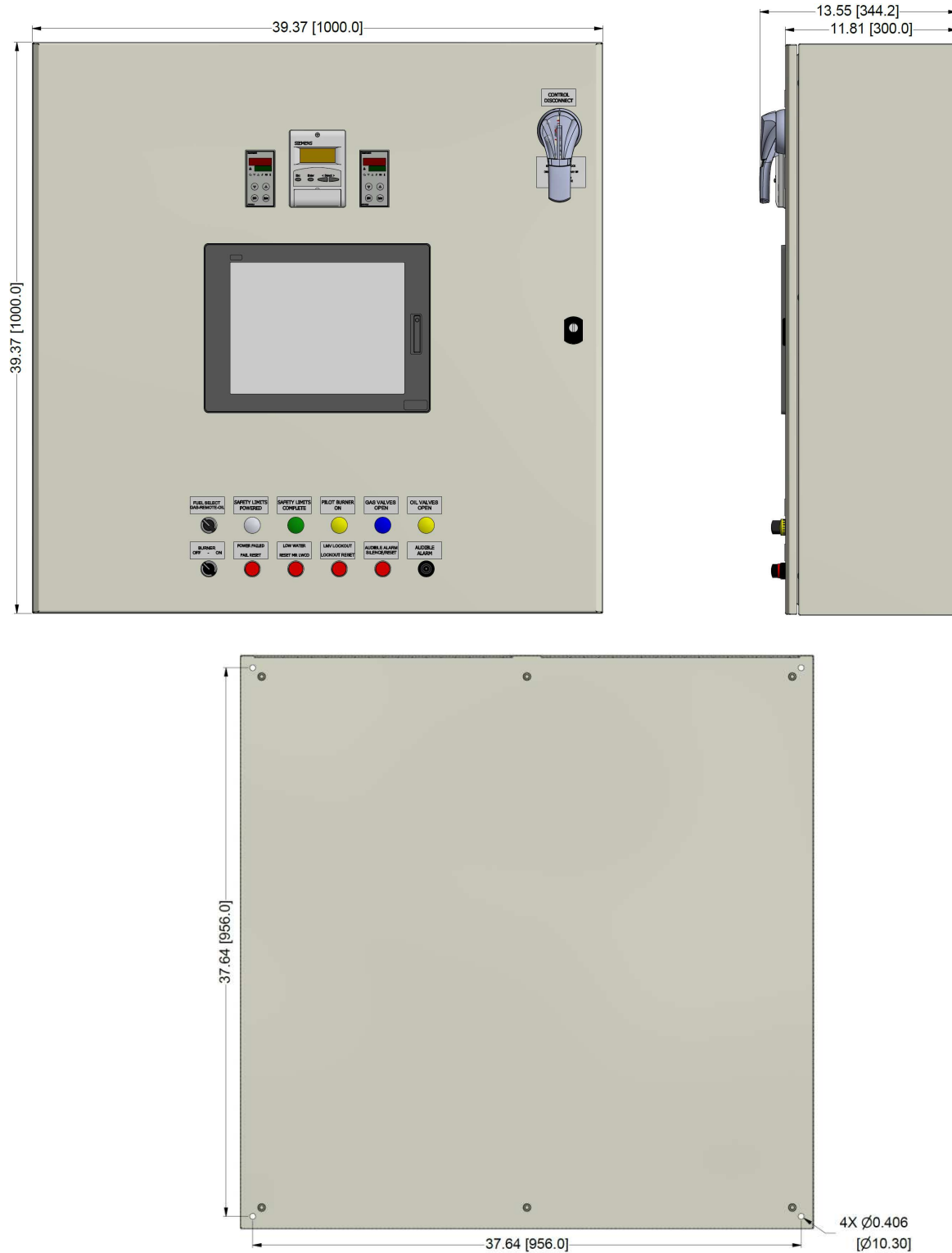

TS-CExx(3/4)-2xxx-x2x2-xxxx

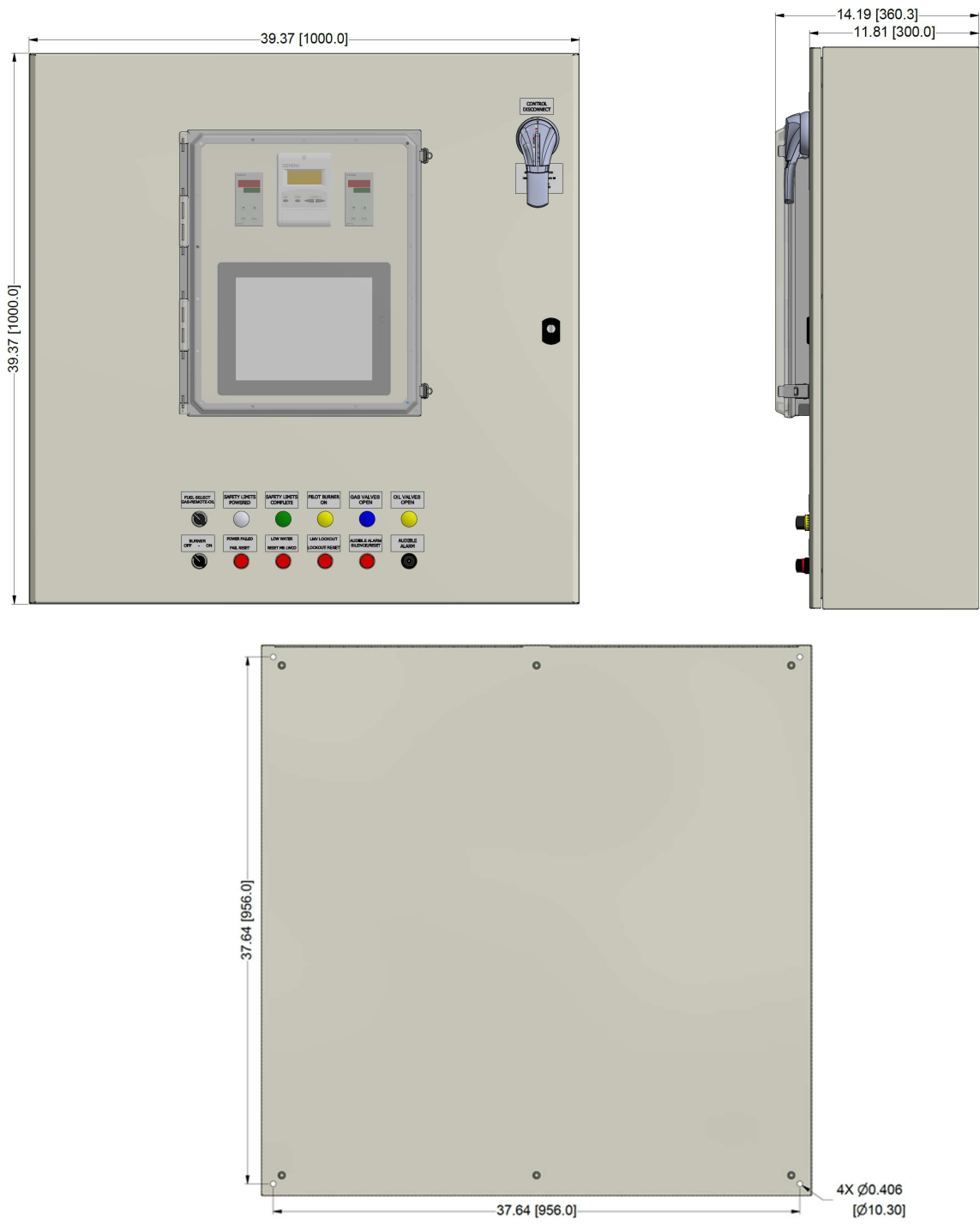

Information in this publication is based on current specifications. The company reserves the right to make changes in specifications and models as design improvements are introduced. Product or company names mentioned herein may be the trademarks of their respective owners. © 2009 SCC Inc.