

VKO Series

VKO... Modulating Oil Valves

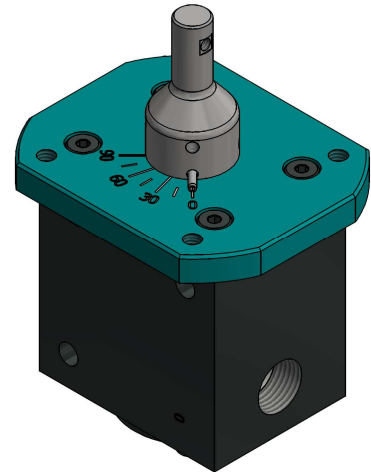

Description

VKO... series modulating oil valves control the flow of #2 oil, #4 oil, #6 oil, liquid propane, or B20 biodiesel.

Features

- UL listed for use with #2 oil and B20 biodiesel
- Up to 500 psi static pressure
- Up to 500 psi differential pressure
- Low leakage rate at full closed position
- Corrosion-resistant for outdoor applications
- Clear position indication on a laser-etched, anodized dial
- Crank arm kits available for linkage applications
- Valve actuator assemblies available (Document No. VA-6000)

Application

VKO... series modulating oil valves control the flow of #2 oil, #4 oil, #6 oil, liquid propane, or B20 biodiesel. Valves are positioned using either a crank arm kit or rotary actuator. VKO... series oil valves are not intended for use as shutoff valves. The valve body contains (2) identical female pipe threads for an oil tight seal with NPT piping.

Product Part Numbers

The part number structure for VKO... series modulating oil valves is shown below. Not all possible part number combinations are available.

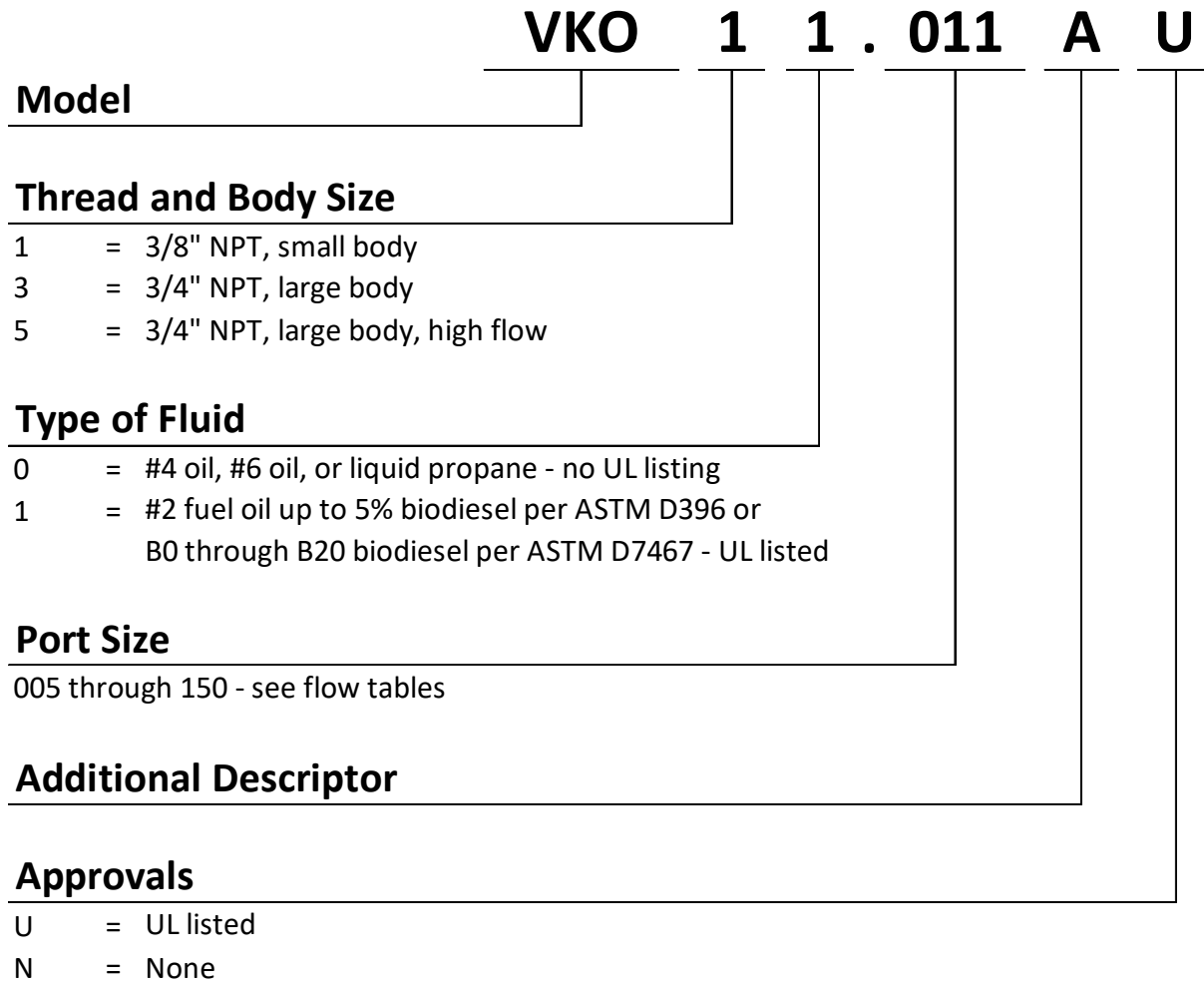

Accessories

VA... Valve Actuator Assemblies

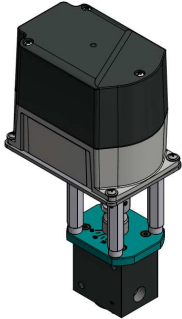

Valve actuator assemblies ensure proper shaft alignment and engagement. A VKO... valve, SQM... actuator, coupling, and bracket are built, tested, and shipped as a VA... assembly. Valve actuator assemblies are available with the following Siemens actuators:

- SQM45...
- SQM48...
- SQM33...
- SQM40...
- SQM5...

For additional information see Document No. VA-6000.

CA-VKO-x

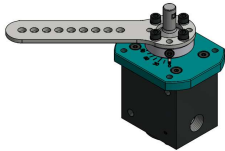

A crank arm kit can be added to any VKO... series oil valve for use with a linkage system. Three crank arm kits are available. For more information, see Document No. CPBK-8000.

CA-VKO-1 – Thick crank arm kit with holes

CA-VKO-2 – Standard crank arm kit with holes

CA-VKO-3 – Standard crank arm kit with slot

Materials

Below is a valve cross-section that identifies the materials used in VKO... valves. All fasteners (not shown) are alloy steel.

Table 1: VKO... Valve Materials

Item	Description	Material
1	Valve Body	Painted Steel
2	Shaft	Tool Steel
3	Bonnet (x2)	Painted Brass
4	Shaft Seal (x2)	Viton
5	Bonnet Seal (x2)	Viton
6	Sleeve	Bronze
7	Shaft Adapter	303 Stainless Steel
8	Dial	Aluminum 6061-T6

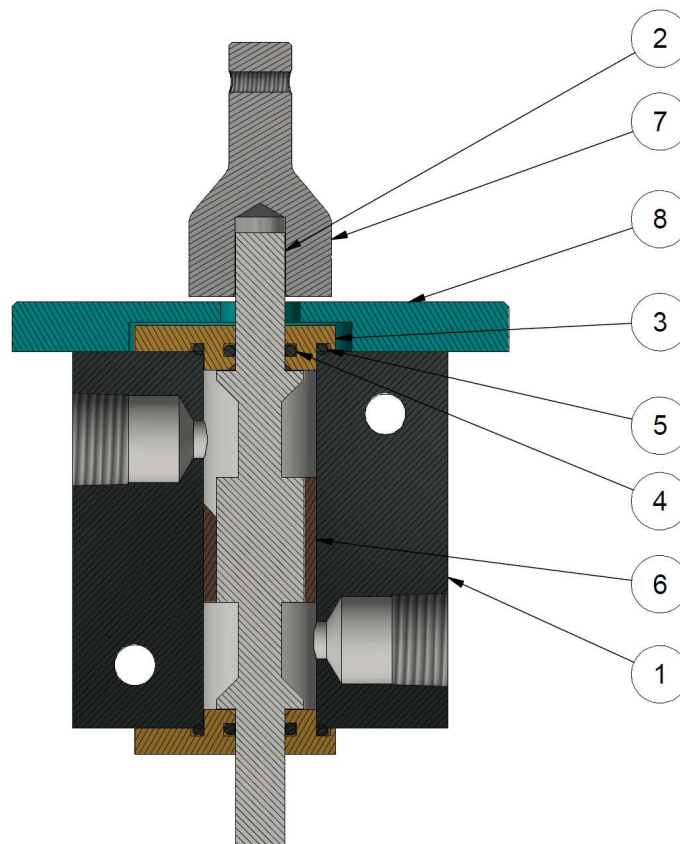

Figure 1: VKO... Valve Cross-Section View

Installation

- The VKO... valve can be mounted in any position.
- The inlet connection is labeled “I” and the outlet connection is labeled “O”.
- A 50 micron (270 mesh) or finer filter is required upstream of the VKO... valve to avoid scale and other particulates from entering the valve. Any pipe between the filter and the valve must be clean.
- Appropriate thread sealant should be applied to all NPT threaded pipe connections. Do not use more than necessary. Excess sealant could become lodged inside the valve body.
- Two unthreaded mounting holes through the valve body are provided in each VKO... valve for securing the valve to a rigid mounting surface. This is especially recommended when a rotary actuator is being mounted on top of the VKO... valve.
- VKO... valves do not require any maintenance.
- From the 0° fully closed position, the valve shaft must be rotated clockwise to increase flow.

Flow Data

Full open flow of #2 oil or B20 biodiesel through the UL listed VKO...U valves is shown in Table 2 at common differential pressures. The table was made assuming an oil temperature of 60°F and a specific gravity of 0.849. For other oil temperatures or specific gravities, the oil flow equation on page 8 can be used to determine the proper valve size.

Table 2: UL Listed VKO...U #2 Oil or B20 Flow Rates (gph) at Full Open Position

Part Number	Cv	Differential Pressure (psi)										
		10	20	30	40	50	75	100	150	200	250	300
VKO11.005AU	0.023	4.7	6.7	8.2	9.5	11	13	15	18	21	24	26
VKO11.011AU	0.064	13	19	23	26	29	36	42	51	59	66	72
VKO11.019AU	0.136	28	40	49	56	63	77	89	108	125	140	153
VKO11.029AU	0.232	48	68	83	96	107	131	151	185	214	239	262
VKO11.036AU	0.304	63	89	108	125	140	171	198	242	280	313	343
VKO11.046AU	0.400	82	116	143	165	184	226	260	319	368	412	451
VKO11.056AU	0.504	104	147	180	208	232	284	328	402	464	519	568
VKO11.070AU	0.616	127	179	220	254	284	347	401	491	567	634	695
VKO31.060CU	0.78	161	227	278	321	359	440	508	622	718	803	880
VKO31.074CU	1.06	218	309	378	437	488	598	690	845	976	1091	1196
VKO31.084CU	1.31	270	381	467	540	603	739	853	1045	1206	1349	1478
VKO31.096CU	1.65	340	481	588	680	760	930	1074	1316	1519	1699	1861
VKO51.100DU	1.95	402	568	695	803	898	1100	1270	1555	1796	2008	2199
VKO51.120DU	2.38	490	693	849	980	1096	1342	1550	1898	2192	2450	2684
VKO51.145DU	2.82	581	821	1006	1161	1298	1590	1836	2249	2597	2903	3181
VKO51.150CU	3.78	778	1101	1348	1557	1741	2132	2461	3015	3481	3892	4263

Full open flow of #6 oil through the VKO...N valves is shown in Table 3 at common differential pressures. The table was made assuming an oil temperature of 240°F and a specific gravity of 0.900. For other oil temperatures or specific gravities, the oil flow equation on page 8 can be used to determine the proper valve size.

Table 3: VKO...N #6 Oil Flow Rates (gph) at Full Open Position

Part Number	Cv	Differential Pressure (psi)										
		10	20	30	40	50	75	100	150	200	250	300
VKO10.005AN	0.023	4.6	6.5	8.0	9.2	10	13	15	18	21	23	25
VKO10.011AN	0.064	13	18	22	26	29	35	40	50	57	64	70
VKO10.019AN	0.136	27	38	47	54	61	74	86	105	122	136	149
VKO10.029AN	0.232	46	66	80	93	104	127	147	180	208	232	254
VKO10.036AN	0.304	61	86	105	122	136	167	192	235	272	304	333
VKO10.046AN	0.400	80	113	139	160	179	219	253	310	358	400	438
VKO10.056AN	0.504	101	143	175	202	225	276	319	390	451	504	552
VKO10.070AN	0.616	123	174	213	246	275	337	390	477	551	616	675
VKO30.060CN	0.78	156	221	270	312	349	427	493	604	698	780	854
VKO30.074CN	1.06	212	300	367	424	474	581	670	821	948	1060	1161
VKO30.084CN	1.31	262	371	454	524	586	718	829	1015	1172	1310	1435
VKO30.096CN	1.65	330	467	572	660	738	904	1044	1278	1476	1650	1807
VKO50.100DN	1.95	390	552	675	780	872	1068	1233	1510	1744	1950	2136
VKO50.120DN	2.38	476	673	824	952	1064	1304	1505	1844	2129	2380	2607
VKO50.145DN	2.82	564	798	977	1128	1261	1545	1784	2184	2522	2820	3089
VKO50.150CN	3.78	756	1069	1309	1512	1690	2070	2391	2928	3381	3780	4141

Flow Data (continued)

Full open flow of liquid propane through the VKO...N valves is shown in Table 4 at common differential pressures. The table was made assuming a fluid temperature of 60°F and a specific gravity of 0.507. For other fluid temperatures or specific gravities, the flow equation on page 8 can be used to determine the proper valve size.

Table 4: VKO...N Liquid Propane Flow Rates (gph) at Full Open Position

Part Number	Cv	Differential Pressure (psi)										
		10	20	30	40	50	75	100	150	200	250	300
VKO10.005AN	0.023	6.1	8.7	11	12	14	17	19	24	27	31	34
VKO10.011AN	0.064	17	24	30	34	38	47	54	66	76	85	93
VKO10.019AN	0.136	36	51	63	72	81	99	115	140	162	181	198
VKO10.029AN	0.232	62	87	107	124	138	169	195	239	276	309	339
VKO10.036AN	0.304	81	115	140	162	181	222	256	314	362	405	444
VKO10.046AN	0.400	107	151	185	213	238	292	337	413	477	533	584
VKO10.056AN	0.504	134	190	233	269	300	368	425	520	601	672	736
VKO10.070AN	0.616	164	232	284	328	367	450	519	636	734	821	899
VKO30.060CN	0.78	208	294	360	416	465	569	657	805	930	1039	1138
VKO30.074CN	1.06	282	399	489	565	632	774	893	1094	1263	1412	1547
VKO30.084CN	1.31	349	494	605	698	781	956	1104	1352	1561	1745	1912
VKO30.096CN	1.65	440	622	762	879	983	1204	1390	1703	1966	2198	2408
VKO50.100DN	1.95	520	735	900	1039	1162	1423	1643	2012	2324	2598	2846
VKO50.120DN	2.38	634	897	1098	1268	1418	1737	2006	2456	2836	3171	3474
VKO50.145DN	2.82	751	1063	1302	1503	1680	2058	2376	2910	3361	3757	4116
VKO50.150CN	3.78	1007	1424	1745	2015	2252	2758	3185	3901	4505	5036	5517

Flow Data (continued)

Flow through the valve body can be calculated using the equation below and the C_v values from Tables 2-4.

$$(Eq. 1) \quad Q = 60 \times C_v \times \sqrt{\frac{\Delta P}{G}}$$

C_v = Flow coefficient (see Tables 2-4)

G = Specific gravity of oil or liquid propane (see Table 5 or 6)

ΔP = Differential pressure across valve in psi

Q = Oil or liquid propane flow in gph

Boiler horsepower is calculated using Equation 2 below.

$$(Eq. 2) \quad \text{Boiler hp} = Q \times (HHV) \times \eta \times \frac{1 \text{ Boiler hp}}{33,475 \text{ BTU/hr}}$$

Q = Oil or liquid propane flow in gph

HHV = Higher heating value in BTU/gal (see Table 7)

η = Boiler efficiency (example: 80% = 0.80)

Table 5: Specific Gravity and Viscosity of #2 Fuel Oil and B20 at Common Temperatures

Temperature of Oil (°F)	Specific Gravity	Viscosity (SSU)
20	0.87	57
40	0.86	47
60	0.86	40
80	0.85	38
100	0.84	34
120	0.83	33

Table 6: Specific Gravity and Viscosity of #6 Fuel Oil at Common Temperatures

Temperature of Oil (°F)	Specific Gravity	Viscosity (SSU)
200	0.92	125
220	0.91	90
240	0.90	79
260	0.89	60
280	0.89	56
300	0.88	46

Table 7: Typical Higher Heating Values (HHV)

Type of Fuel	HHV (BTU/gal)
#2 fuel oil / B20	141,000
#6 fuel oil	151,000
LPG	95,000

Specifications

Physical characteristics	Connection	3/8" NPT or 3/4" NPT
	Approvals	
	- VKO...U	UL 842, UL 842B
	- VKO...N	None
	Operating stroke	90°
	Minimum service life	500,000 cycles at 300 psid
	Weight	
- VKO1...	3.0 lb [1.4 kg]	
- VKO3..., VKO5...	7.7 lb [3.5 kg]	

Operating environment	Controlled media	
	- VKO...U	#2 fuel oil up to 5% biodiesel per ASTM D396 or B0 through B20 biodiesel per ASTM D7467
	- VKO...N	#4 fuel oil, #6 fuel oil, or liquid propane
	Media temperature	
	- VKO...U	10 to 160°F [-12 to 71°C]
	- VKO...N	10 to 300°F [-12 to 149°C]
	Ambient temperature	10 to 160°F [-12 to 71°C]
	Maximum static pressure	500 psig [34.5 bar]
	Maximum differential pressure	500 psid [34.5 bar]
	Maximum actuator stall torque ¹	
	- VKO1...	100 in-lb
	- VKO3..., VKO5...	500 in-lb
	Environment	Indoor or outdoor service
Upstream oil filtration	50 micron (270 mesh) or finer	

¹ Actuator stall torques are typically 2-3 times greater than the rated actuator torque.

Actuator Torque

Table 8: Torque Required to Operate VKO... Valves at Various Differential Pressures (in-lb)

Valve Model	Pressure Drop Across Valve (psi)						
	0	50	100	200	300	400	500
VKO1...	4	7	9	11	14	16	18
VKO3..., VKO5...	7	16	24	40	44	66	79

Dimensions

Dimensions in inches [mm]

VK01... Valve Dimensions

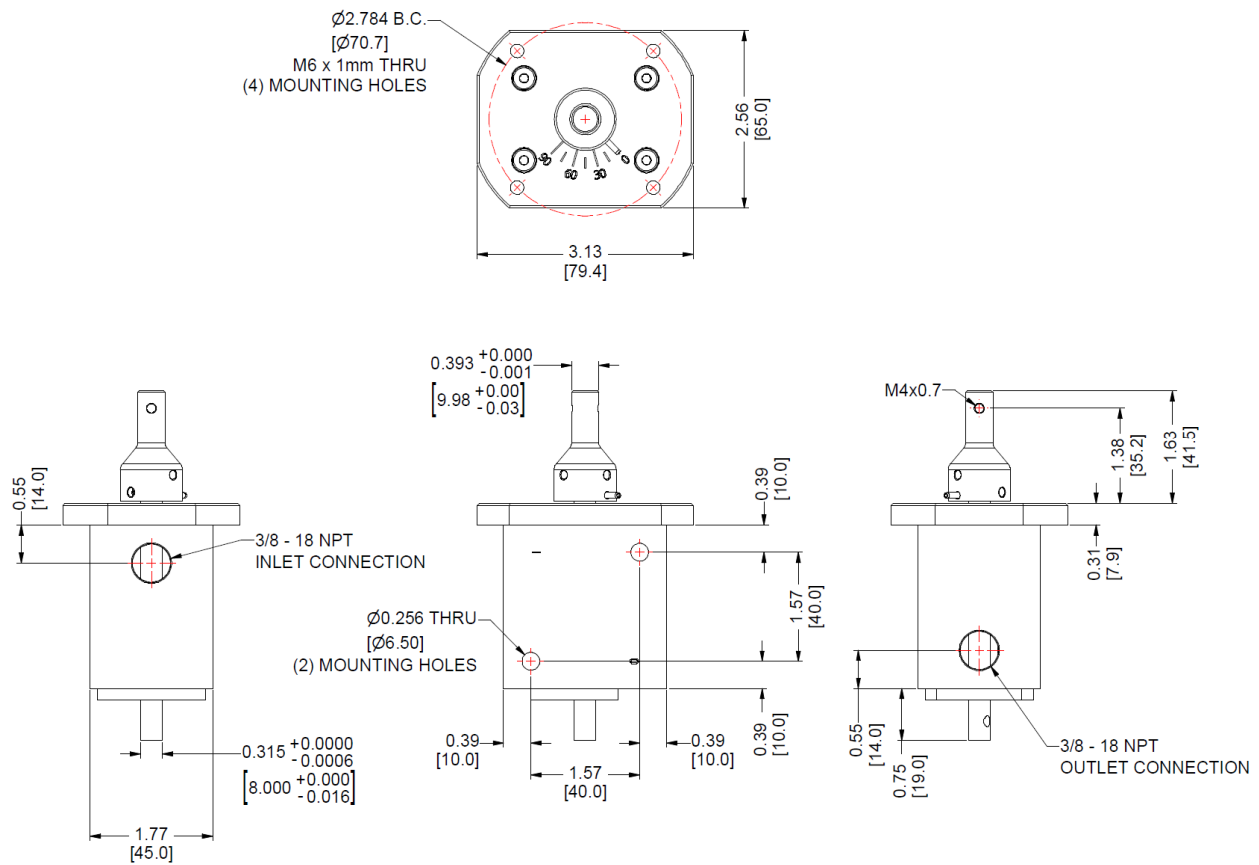

Dimensions (continued)

Dimensions in inches [mm]

VK03... and VK05... Valve Dimensions

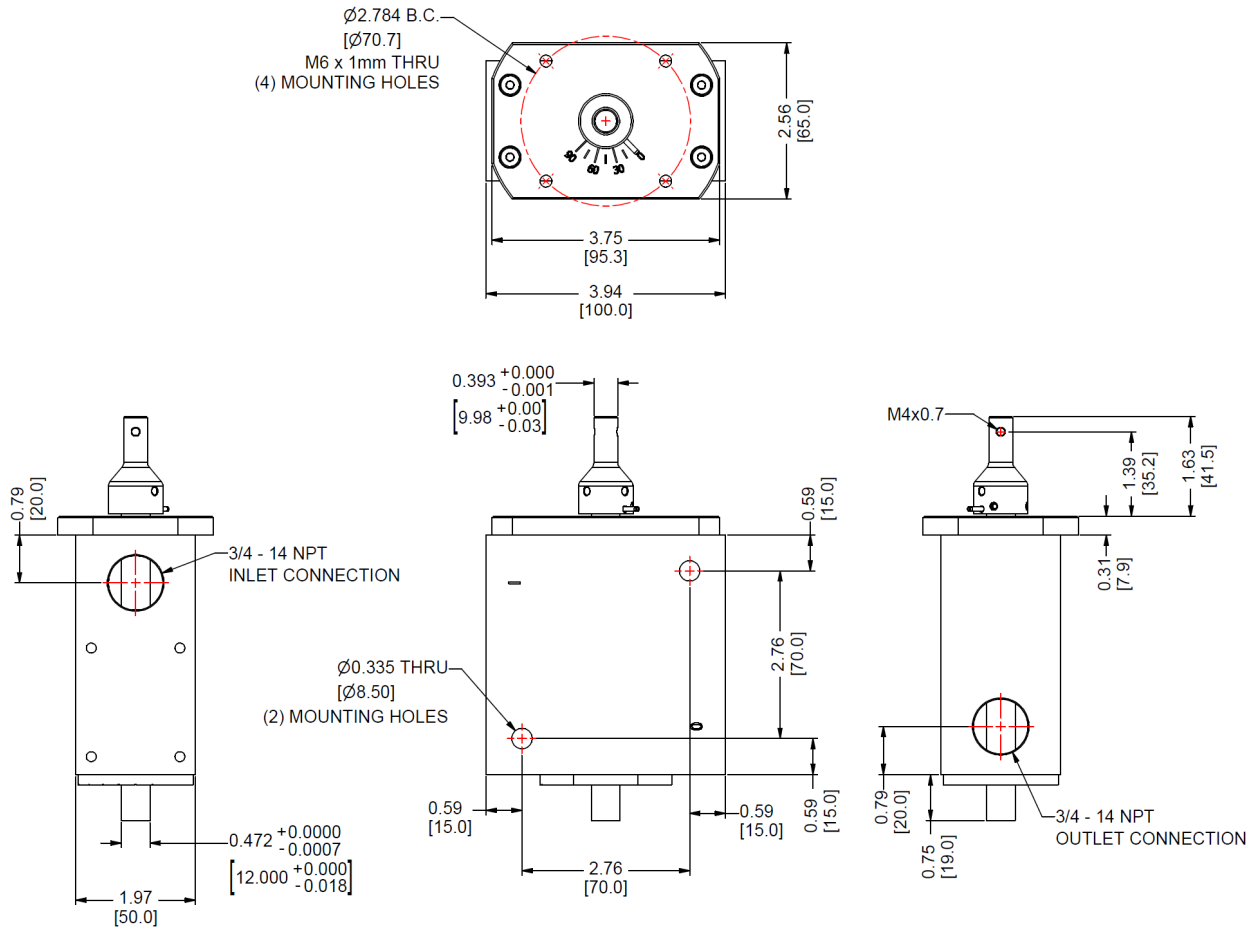

Dimensions (continued)

Dimensions in inches [mm]

VKO... Valve with CA-VKO-x Crank Arm Kit

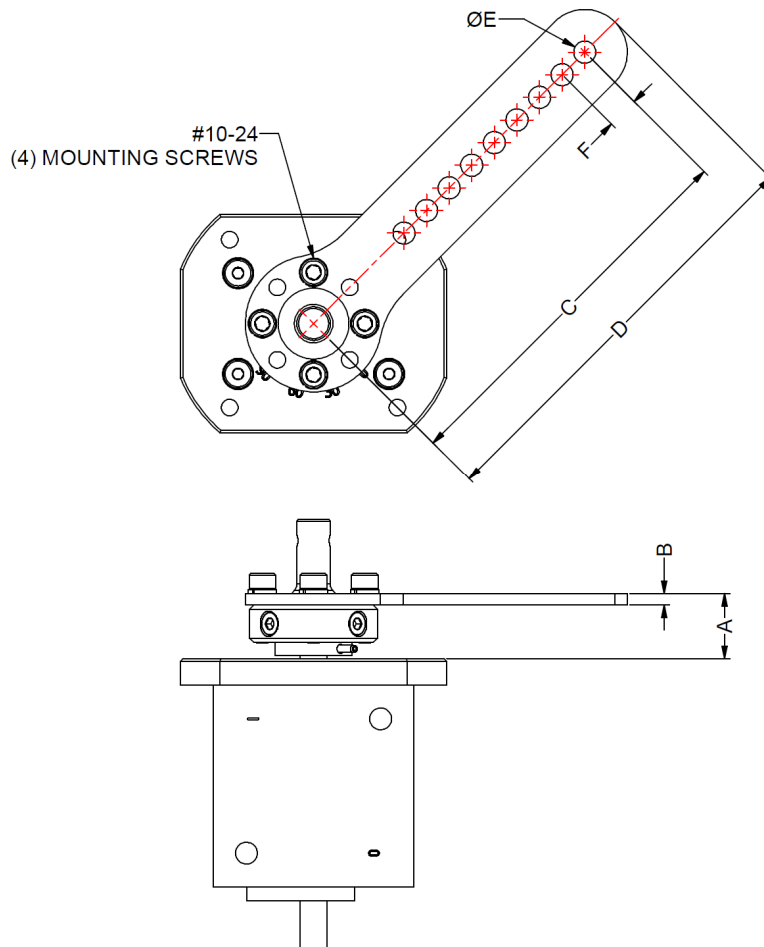

Table 9: CA-VKO-x Crank Arm Kit Dimensions

Part Number	A	B	C	D	E	F
CA-VKO-1	1.00 [25]	0.38 [10]	4.80 [122]	5.25 [133]	0.39 [10] x6	0.58 [15]
CA-VKO-2	0.76 [19]	0.14 [3]	4.50 [114]	5.00 [127]	0.26 [7] x9	0.38 [10]
CA-VKO-3	0.76 [19]	0.14 [3]	4.50 [114]	5.00 [127]	0.26 [7] slot	3.00 [76] slot

Information in this publication is based on current specifications. The company reserves the right to make changes in specifications and models as design improvements are introduced. Product or company names mentioned herein may be the trademarks of their respective owners. © 2022 SCC Inc.