

TS Series

TS... Touchscreen Kits

for use with LMV3, LMV5 and RWF... Controls



Touchscreen

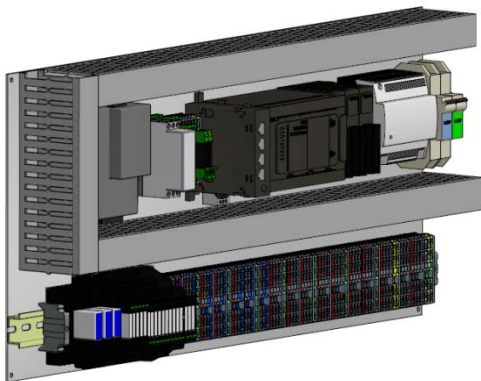
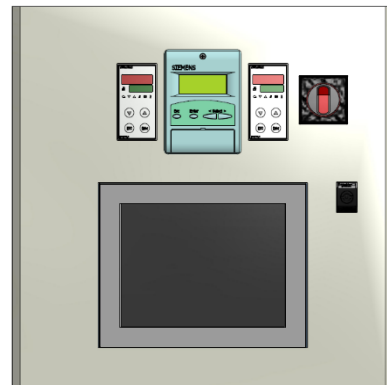

Plate Kit



Enclosure

Description

TS... series touchscreen kits provide a human machine interface (HMI) with a Siemens LMV3 or LMV5 linkageless control. Each kit provides data collection and trending for a hot water or steam boiler. An optional RWF55 control for load or water level modulation easily interfaces with TS... series touchscreen kit.

Each TS... touchscreen kit includes a 6" or 10" touchscreen along with a plate kit. The touchscreen and plate kit can be pre-mounted in an enclosure, or mounted by others in a control panel.

A PLC first-out annunciator provides additional analog, digital, temperature, and/or draft controls inputs and outputs.

Flexible communication interface options to the building management system (BMS) provide streamlined data collection, monitoring and control.

Features

- Local touchscreen interface with Siemens LMV/RWF controllers
- Schneider touchscreens available in 6" or 10"
- Boiler graphics and field tag information are field-configured
- LMV... static, fuel and internal lockout and error history displayed
- Fuel-air ratio control curve displayed
- Alarm history stored for most recent 250 faults/alarms
- Detailed annunciation of LMV... digital inputs and outputs
- Remote setpoint, firing rate and/or enable of the LMV... or RWF... via BMS
- Water level control option and status via RWF55
- Metric or Standard units displayed
- English or Spanish languages
- Clear English or Spanish text for alarms
- Circulating pump/isolation valve control outputs for hydronic boilers (option with expanded annunciator)
- Expanded annunciator options include:
 - Four (4) analog inputs with field configurable label, span and type (0-10V, 2-10V, 0-20mA or 4-20mA), low and high alarm setpoints, with auto or manual reset. Totalization available per minute or per hour.
 - Four (4) 1000 RTD temperature inputs with field configurable label, low and high alarm setpoints, with auto or manual reset.
 - Two (2) analog outputs with field configurable span and type (0-10V, 2-10V, 0-20mA or 4-20mA); low and high alarm setpoints, with auto or manual reset. Totalization available per minute or per hour.
 - Two (2) digital outputs with field configurable logic, including on and off delays. Manual or automatic reset.
 - First-out annunciation option, including thirteen (13) 120 VAC inputs with field labeling capability
 - Eight (8) selectable data logging variables stored in CSV format on USB drive
 - Four (4) selectable variables for trending up to 7 days
 - Economizer temperature monitoring, (additional RTD card with four (4) inputs)
 - Draft control using SCC Inc. SQM5... actuator
 - Connection of two additional RWF55 controllers
 - Variable Speed Drive information and setup when preprogrammed VFD (Yaskawa) provided by SCC Inc.

- Variable speed Drive information and setup when preprogrammed VFD (ABB, AB Power Flex, or Danfoss, when provided by others).
- Screen saver with PV, setpoint, demand and status
- Standard Modbus TCP/IP to BMS communications
 - Additional BMS communication options available
- Email communications and text messaging for up to six (6) recipients including alarms, faults and screen shots (screen shot viewer via USB)
- Remote monitoring via Smart Phone or tablet
- Compatible with SCC Master Panel Lead Lag system

Application

TS... touchscreen kits are suited for hydronic boiler, steam boiler, and other applications utilizing an LMV3 or LMV5 linkageless control system.

Components

All TS... touchscreen kits include the following components:

- 6" or 10" touchscreen
- Plate kit including power supply and branch circuit protection
- Cables for quick connections between the plate kit, touchscreen, and LMV... system
- Interconnect terminals for field wiring

The following optional features are available:

- Draft Control
- Annunciation Options Including:
 - 13 digital 120 VAC alarm annunciation inputs.
 - 4 analog inputs (0-20mA - 4-20ma - 0-10V - or 2-10V)
 - 2 analog outputs (0-20mA - 4-20ma - 0-10V - or 2-10V)
 - 4 1000 RTD inputs for general purpose
 - 4 1000 RTD inputs for monitoring economizer temperatures
 - 5 output Relays for:
 - Starting circulating pump on Hot water boilers
 - Monitoring a digital value (2 outputs)
 - Annunciation alarms
 - PLC normal operation indication
- BMS communication other than standard Modbus
- Open plate kit, or in enclosure

Product Part Numbers

	TS	-	0	D	8	B	-	2	5	W
Touchscreen										
Touchscreen Size										
3 = 3" touchscreen										
6 = 6" touchscreen										
0 = 10" touchscreen										
C = 3" touchscreen mounted > 15 ft. away from AZL (LMV5 only)										
F = 6" touchscreen mounted > 15 ft. away from AZL (LMV5 only)										
J = 10" touchscreen mounted > 15 ft. away from AZL (LMV5 only)										
Draft Control										
X = No draft control included										
D = Draft control										
Annunciation and Monitoring Options										
X = No annunciation inputs										
1 = Standard annunciation, 13 120VAC inputs										
2 = 13 120VAC annunciation inputs, and 4 analog inputs										
3 = 13 120 VAC annunciation inputs, and 4 RTD 1000 Ohm inputs										
4 = 13 120 VAC annunciation inputs, and 4 RTD 1000 Ohm inputs dedicated for Economizer										
5 = 13 120 VAC annunciation inputs, 4 analog inputs, and 4 RTD 1000 Ohm inputs										
6 = 13 120 VAC annunciation inputs, 4 analog inputs, and 4 RTD 1000 Ohm inputs dedicated for economizer										
7 = 13 120 VAC annunciation inputs, 4 RTD 1000 Ohm inputs, and 4 RTD 1000 Ohm inputs dedicated for economizer										
8 = 13 120 VAC annunciation inputs, 4 analog inputs, and 4 RTD 1000 Ohm inputs, and 4 RTD 1000 Ohm inputs dedicated for economizer										
Building Management Interface (BMS)										
S = Standard, Modbus TCP/IP										
B = BACnet / IP, or Ethernet / IP										
M = BACnet MS/TP, Modbus RTU, or Metasys N2										
L = LonWorks										
N = Profinet										
P = Profibus										
Enclosure Option										
X = No - din rail kit on plate to be mounted into enclosure (Mounted by others)										
1 = NEMA 1										
2 = NEMA 12, includes cover over touchscreen and AZL/RWF (if applicable)										
4 = NEMA 4X (indoor), includes cover over AZL/RWF (if applicable)										
A = NEMA 1 with cooling fan										
B = NEMA 12 with cooling fan, includes cover over touchscreen and AZL/RWF and fan (if applicable)										
C = NEMA 4X with cooling fan, includes cover over touchscreen and AZL/RWF and fan (if applicable)										
6 = NEMA 1, with manual reset Warrick relay										
7 = NEMA 12, includes cover over touchscreen and AZL/RWF (if applicable), with manual reset Warrick relay										
9 = NEMA 4X (indoor), includes cover over AZL/RWF (if applicable), with manual reset Warrick relay										
F = NEMA 1 with cooling fan, with manual reset Warrick relay										
G = NEMA 12 with cooling fan, includes cover over touchscreen, AZL/RWF, and fan (if applicable), with manual reset Warrick relay										
K = NEMA 4X with cooling fan, includes cover over touchscreen, AZL/RWF, and fan (if applicable), with manual reset Warrick relay										
AZL (Option only with enclosure)										
X = No AZL included (Must be selected with din rail kit on plate)										
3 = AZL23.00A9 mounted to front of enclosure										
5 = AZL52.40B1 mounted to front of enclosure										
RWF (Option only with enclosure)										
X = No RWF included										
L = RWF55.50A9 for external load control										
W = RWF55.50A9 for water level control with transformer										
2 = (2) RWF55.50A9 for external load control and water level control - includes 1 transformer										

Specifications

		3"/6" TS kit	10" TS kit
Physical characteristics	Main power	110-240 VAC	110-240 VAC
	Frequency	60-50 Hz	60-50 Hz
	Touchscreen power	24 VDC	24 VDC
	Power consumption	≤ 205 W	≤ 205 W
	Power consumption with PLC annunciation	≤ 460 W	≤ 460 W
	Dry contacts	2 Amps	2 Amps
Operating environment	Operating temperature	32 to 122 °F [0 to 50 °C]	32 to 131 °F [0 to 55 °C]
	Humidity	Max. 80% with no condensation	Max. 85% with no condensation
	NEMA rating	4X (indoor use)	4X (indoor use)
	Enclosure option	NEMA 1 NEMA 12 (Optional) NEMA 4X (Optional)	NEMA 1 NEMA 12 (Optional) NEMA 4X (Optional)

Connections

3" and 6" Touchscreen kit with LMV5 and optional RWF55 for water level control:

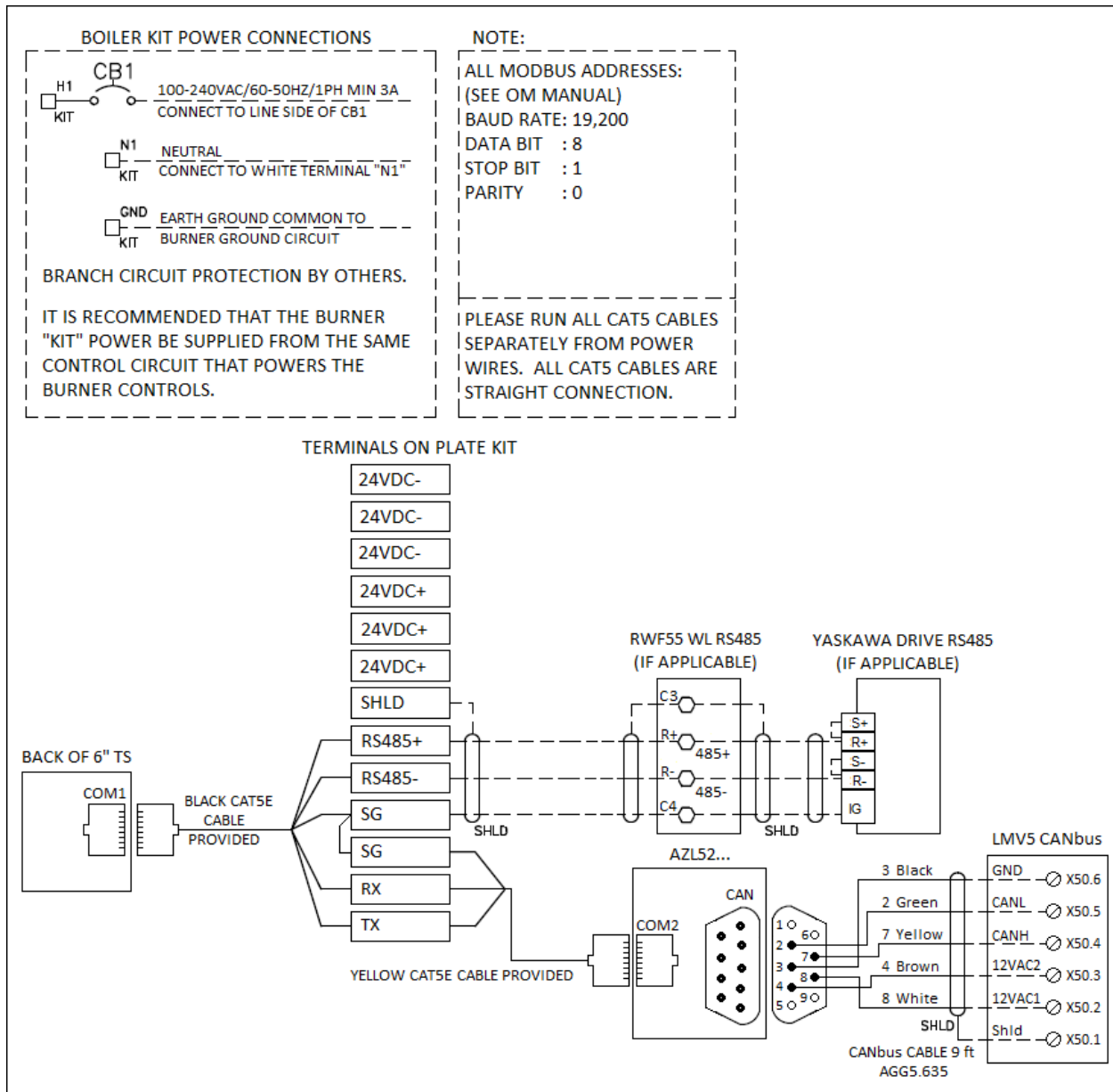

Connections (continued)

3" and 6" Touchscreen kit with LMV5 and optional RWF55 water level control: This diagram is to be used when the touchscreen is mounted more than 15ft away from the AZL

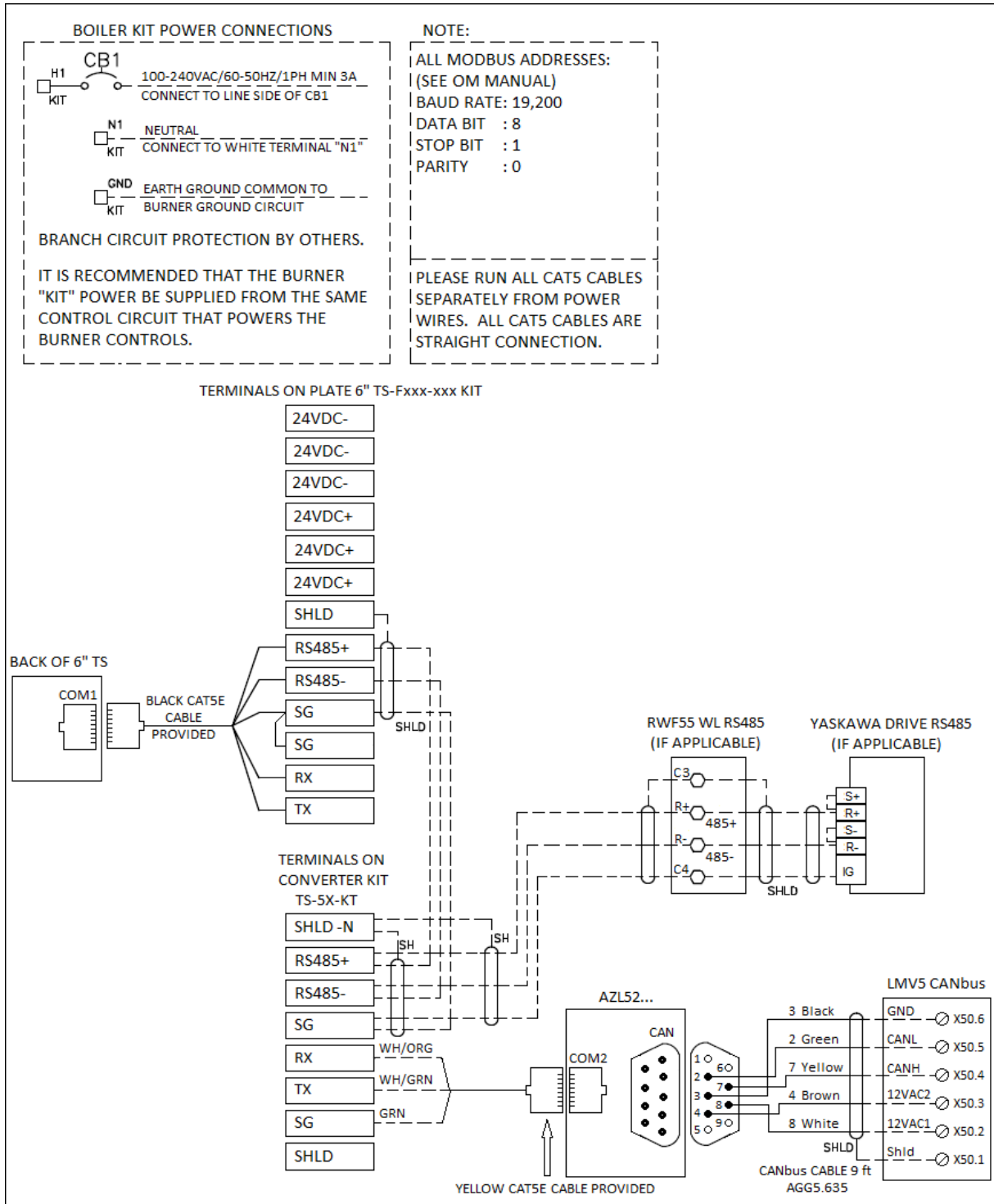

Connections (continued)

3" and 6" Touchscreen kit with LMV3, RWF55 for load control, and optional RWF55 for water level control:

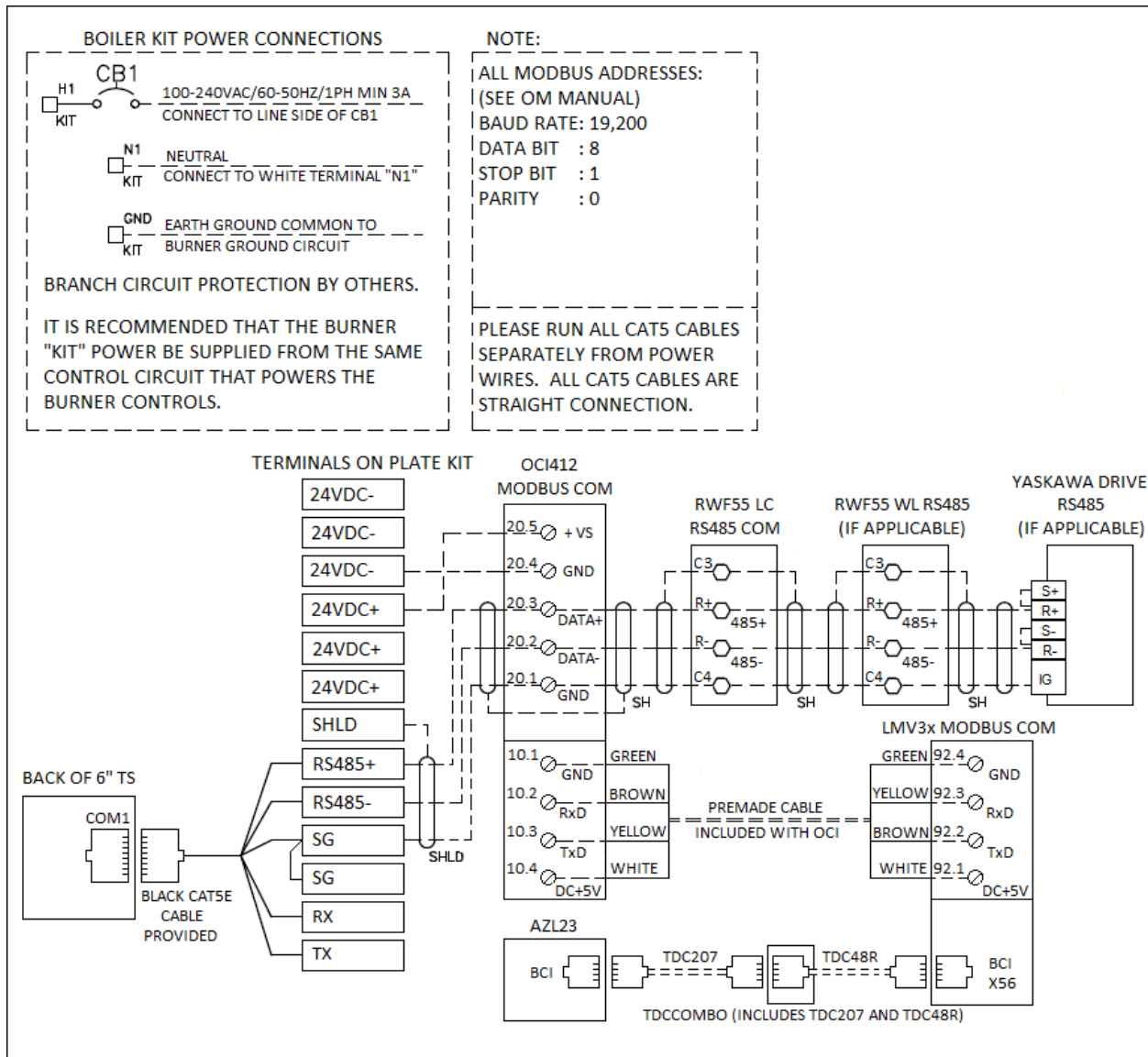

Connections (continued)

3" and 6" Touchscreen kit with LMV3, RWF10 for load control, and optional RWF55 for water level control:

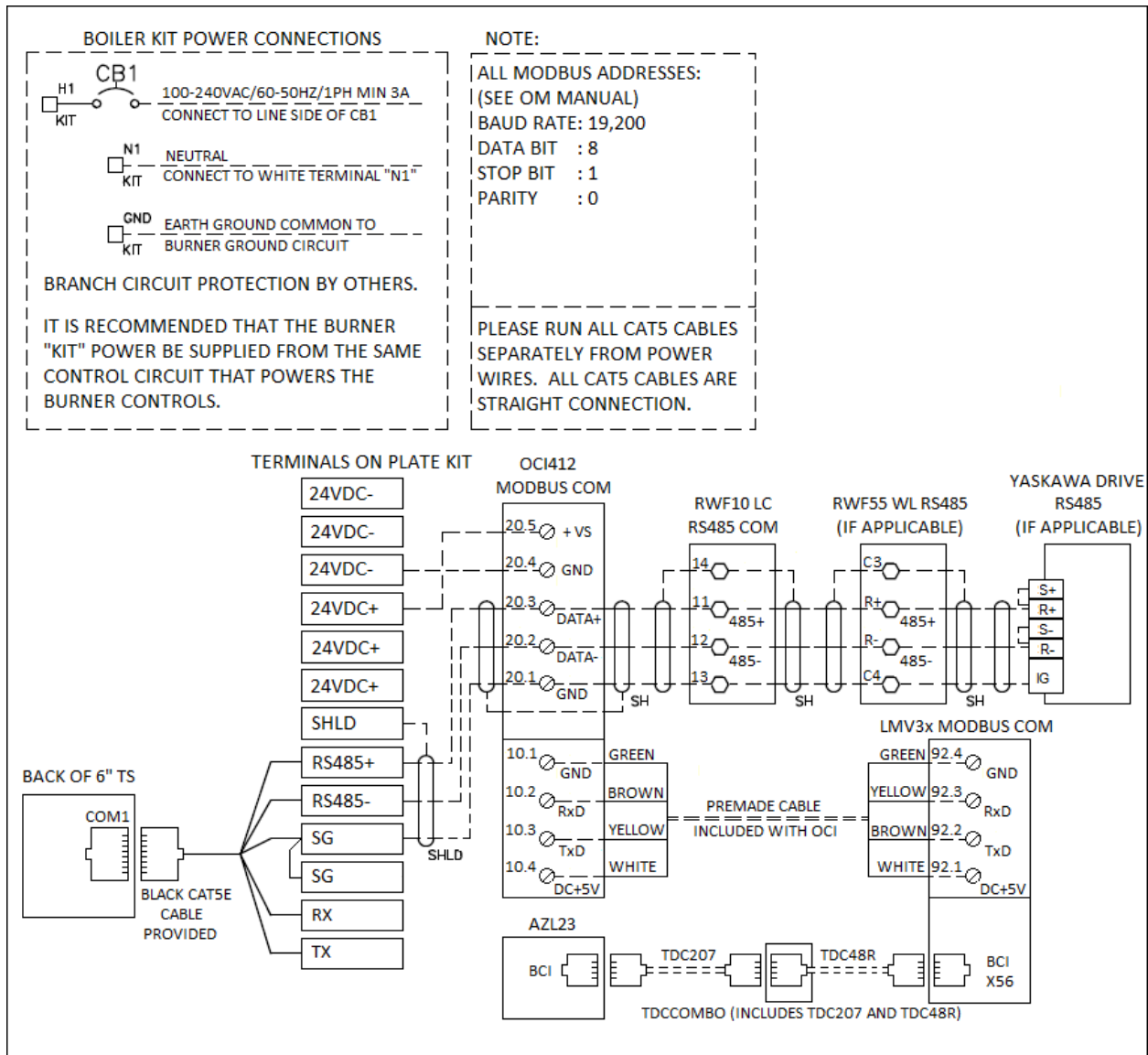

Connections (continued)

10" Touchscreen kit with LMV5 and optional RWF55 for water level control:

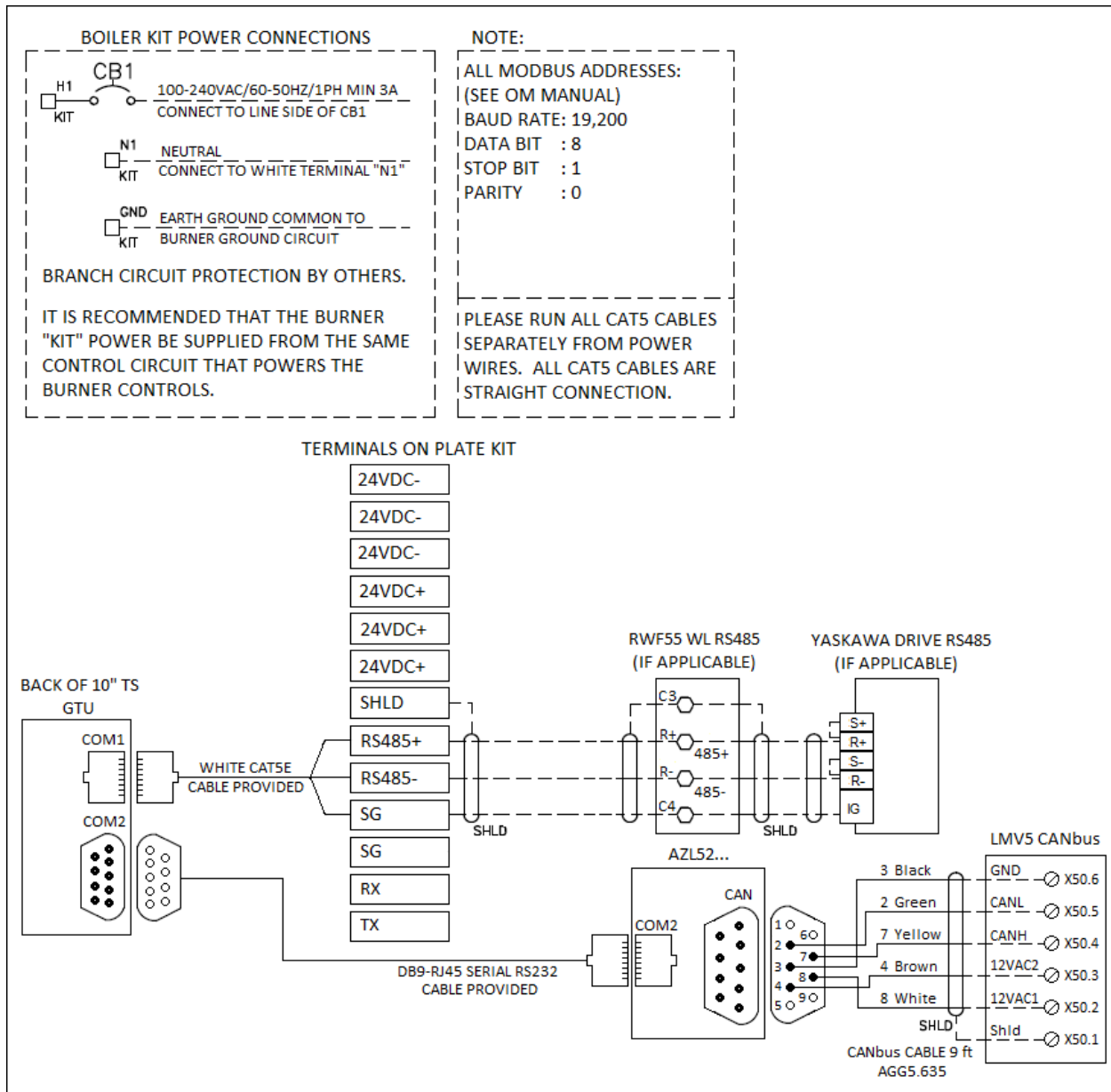

Connections (continued)

10" Touchscreen kit with LMV5 and optional RWF55 for water level control: This diagram is to be used when the touchscreen is mounted more than 15ft away from the AZL

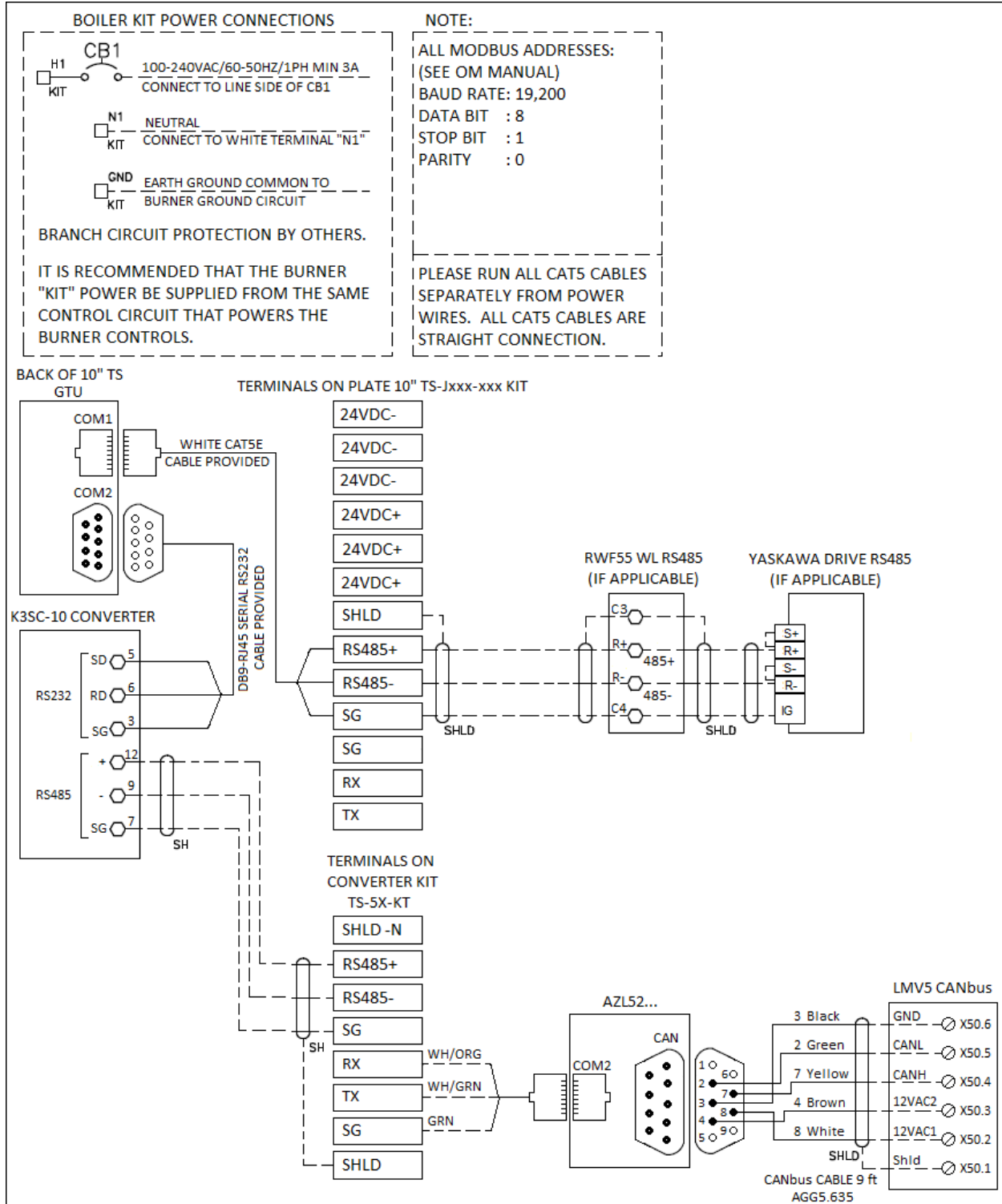

Connections (continued)

10" Touchscreen kit with LMV3, RWF55 for load control, and optional RWF55 for water level control:

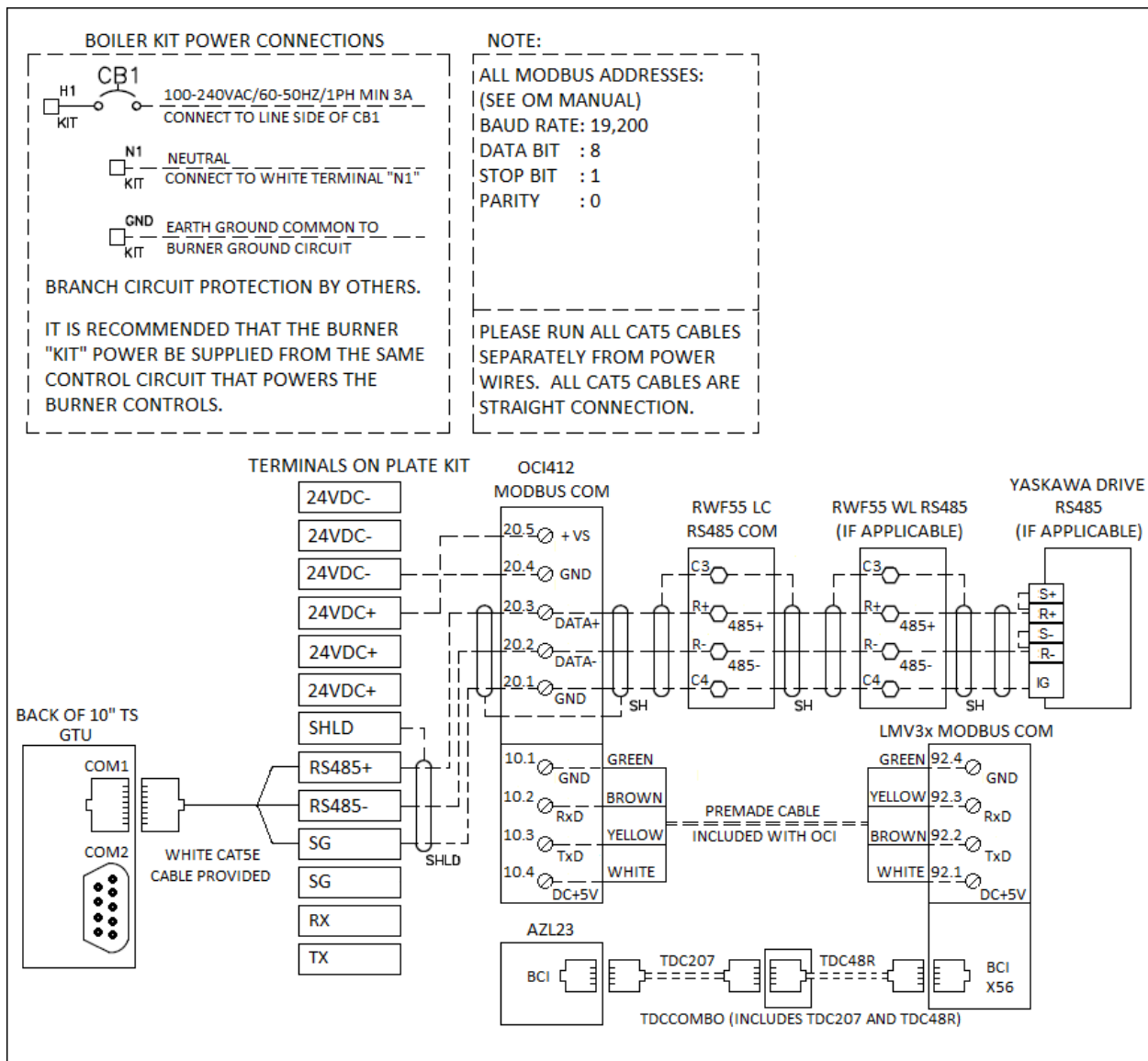

Connections (continued)

10" Touchscreen kit with LMV3, RWF10 for load control, and optional RWF55 for water level control:

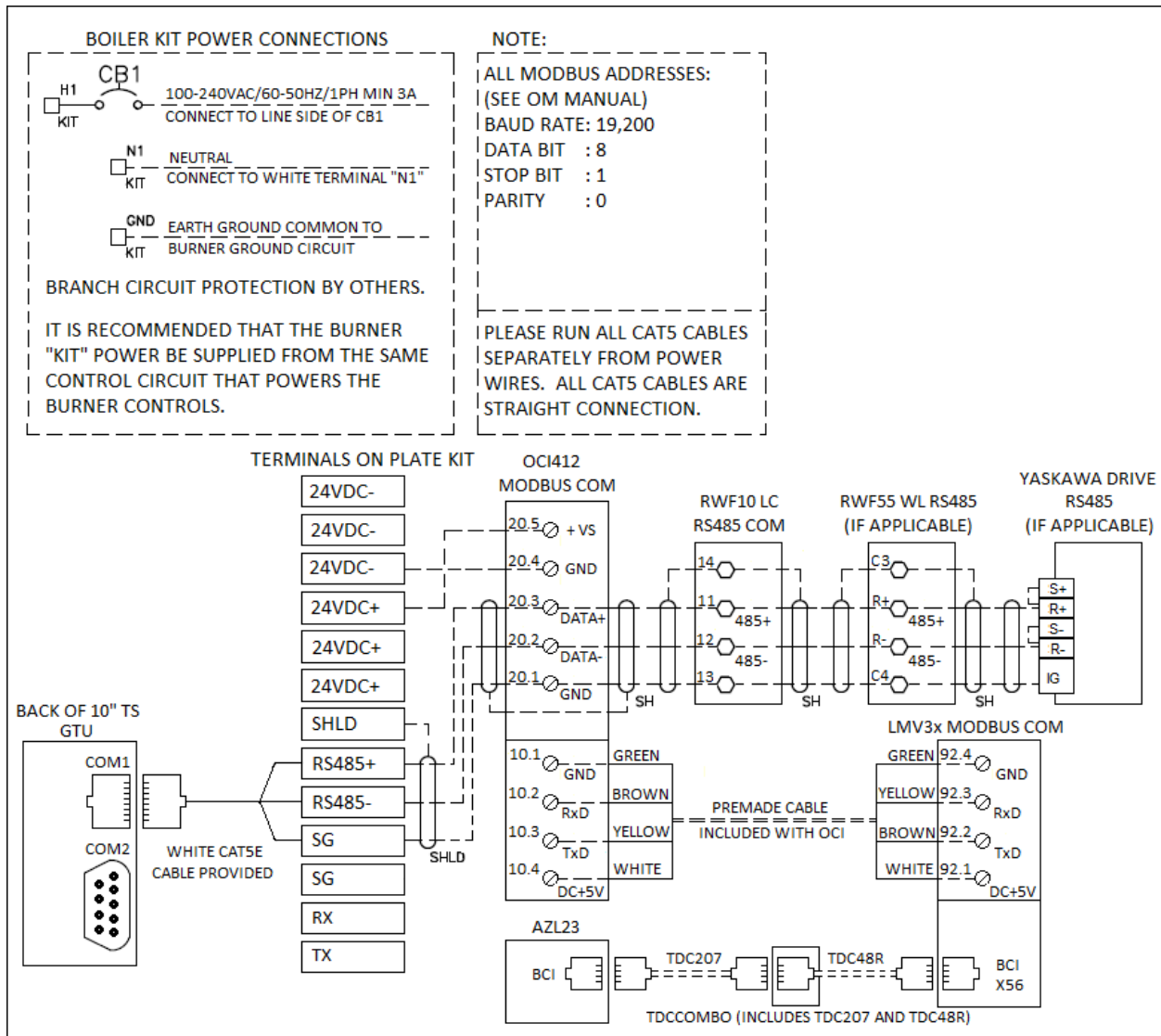

RS485 connection for additional RWF55 for loop control (If applicable)

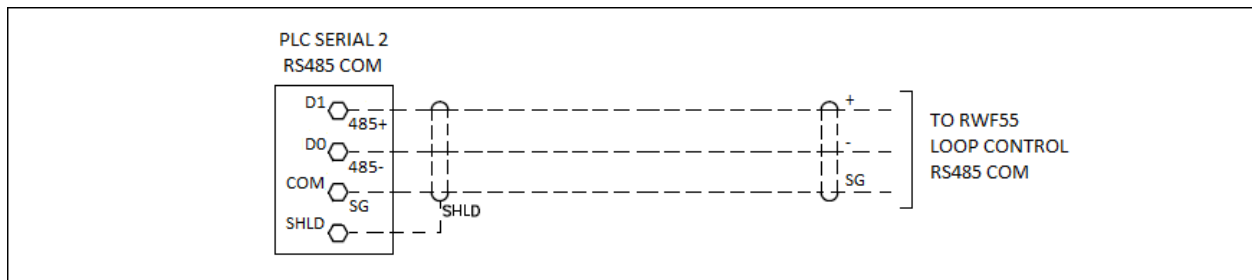

Connections (continued)

Standard annunciation thirteen 120VAC inputs:

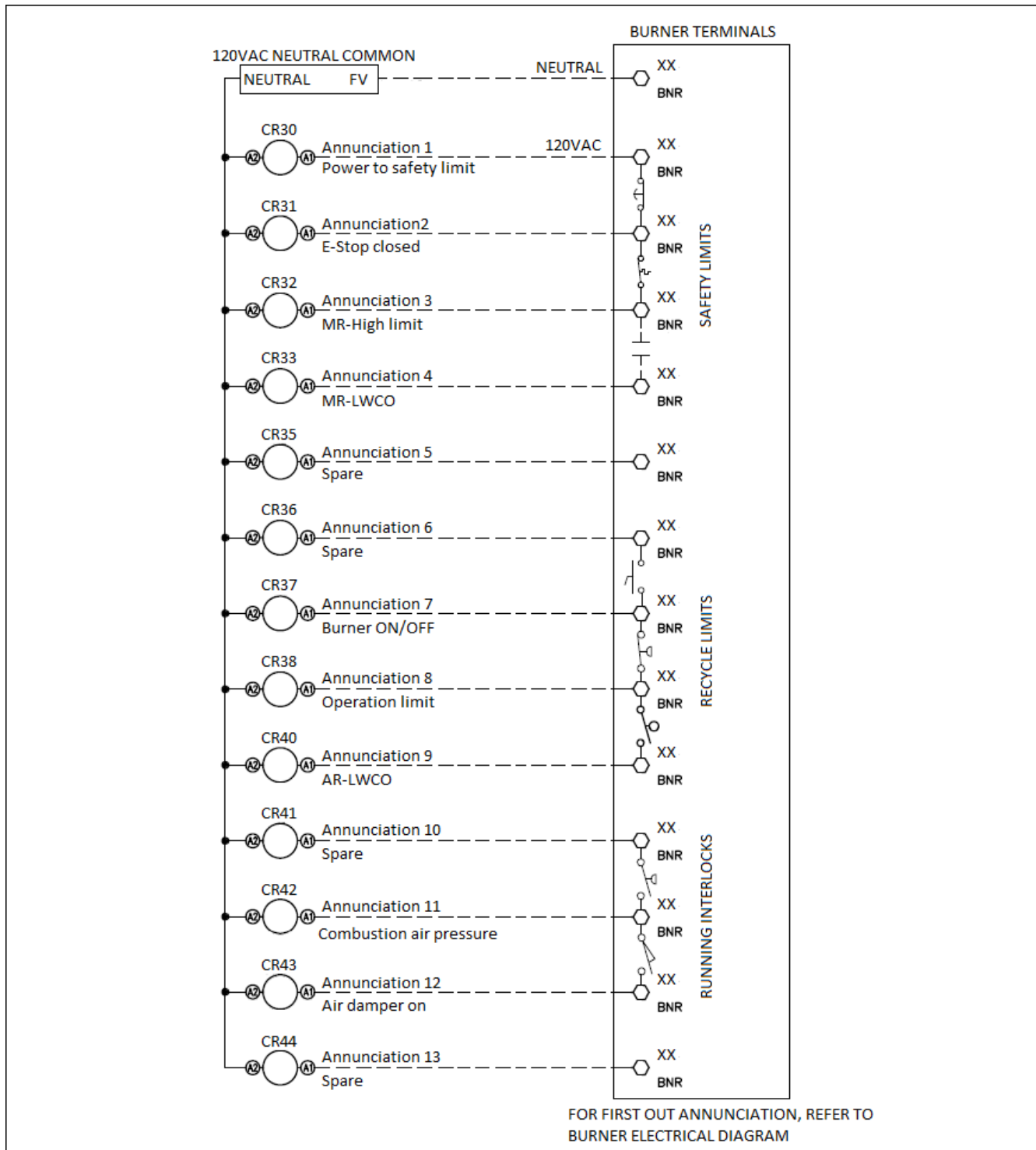

Connections (continued)

Standard annunciation thirteen 120VAC inputs with draft control:

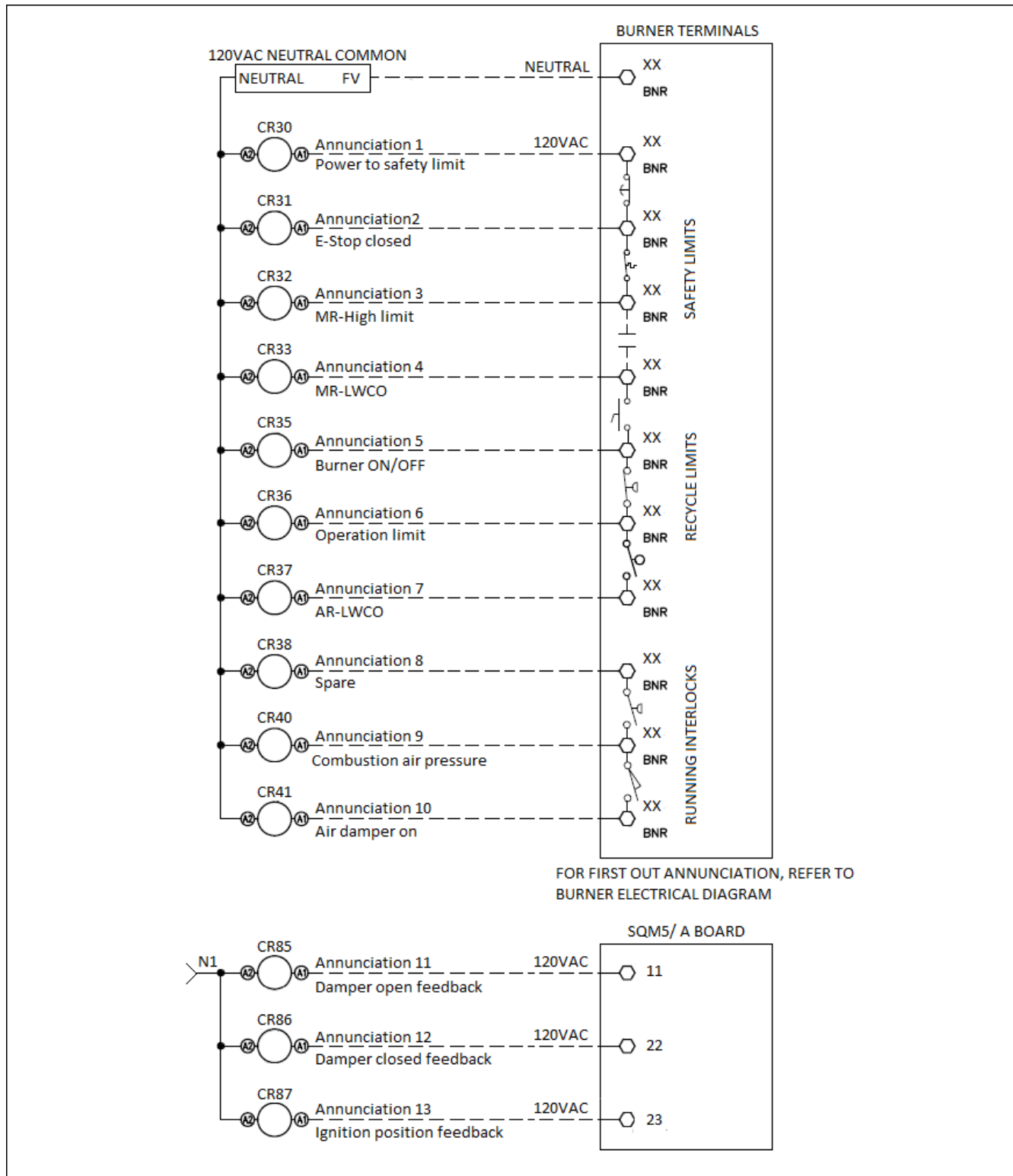

Connections (continued)

Circulating pump proven input terminals: (Hot water systems only)

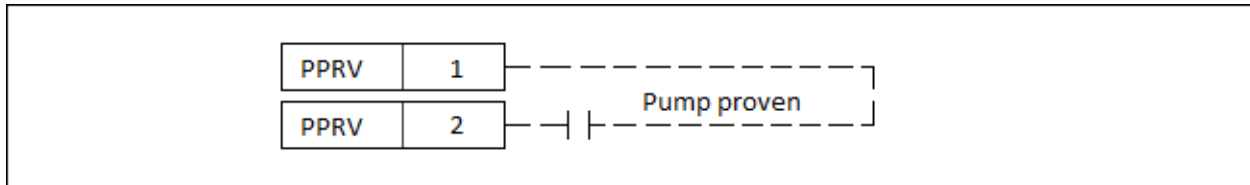

Outputs relay terminals:

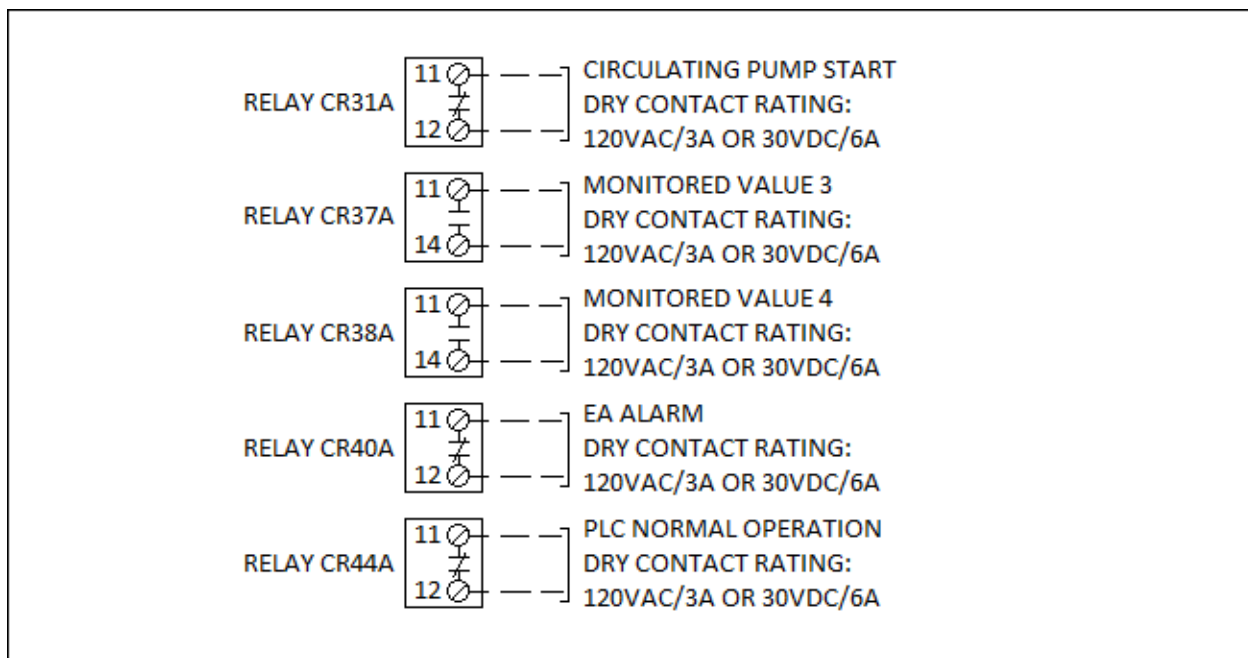

Connections (continued)

Analog input terminals:

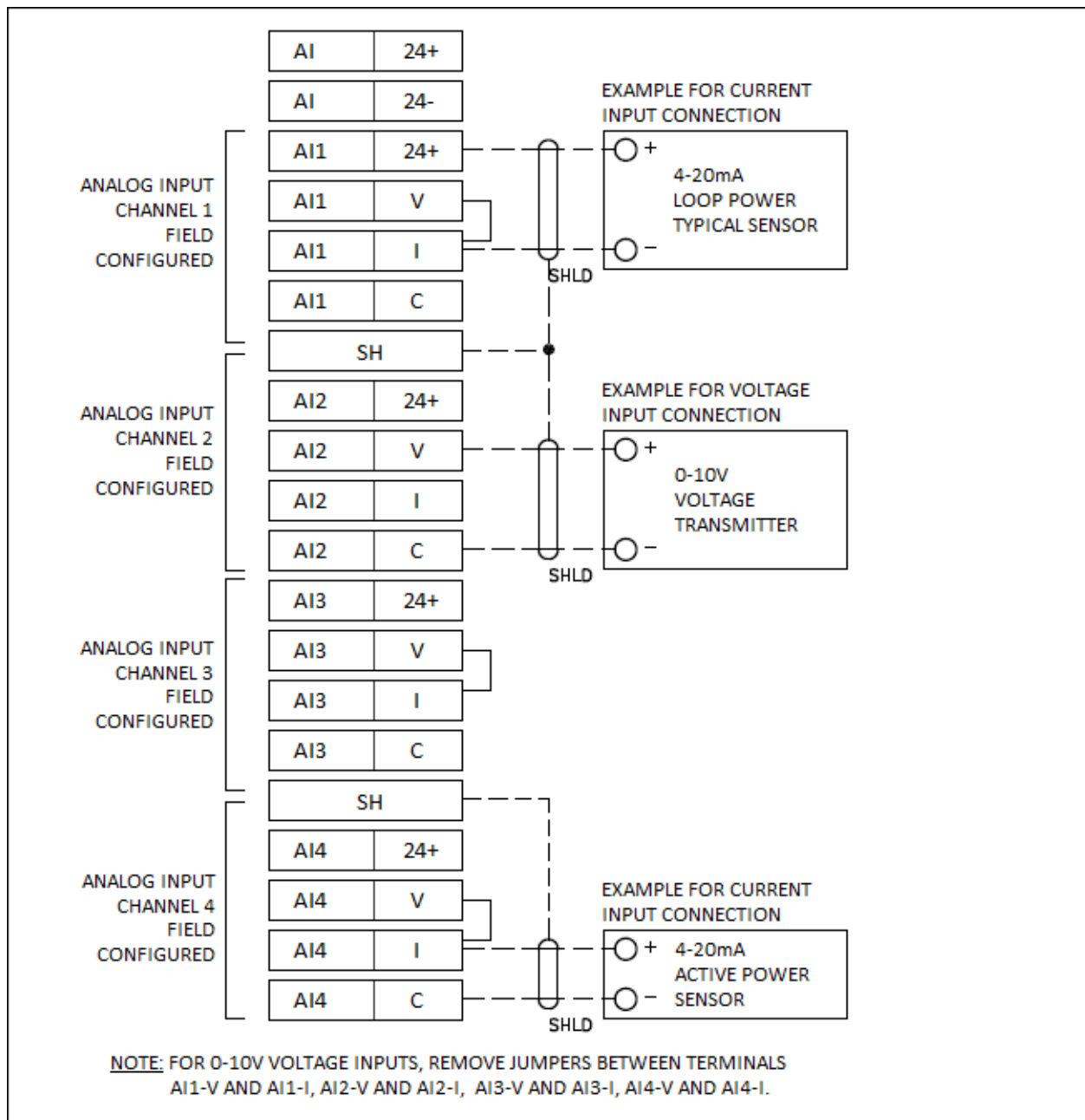

Connections (continued)

Analog output terminals:

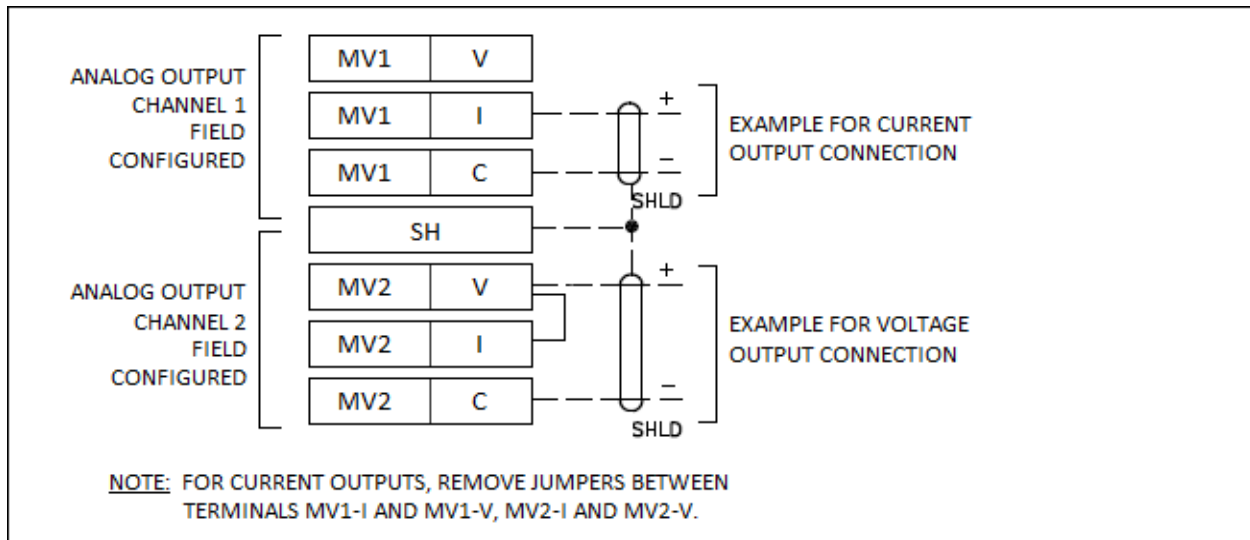

Connections (continued)

RTD Pt or LG-Ni 1000 Ohm input terminals:

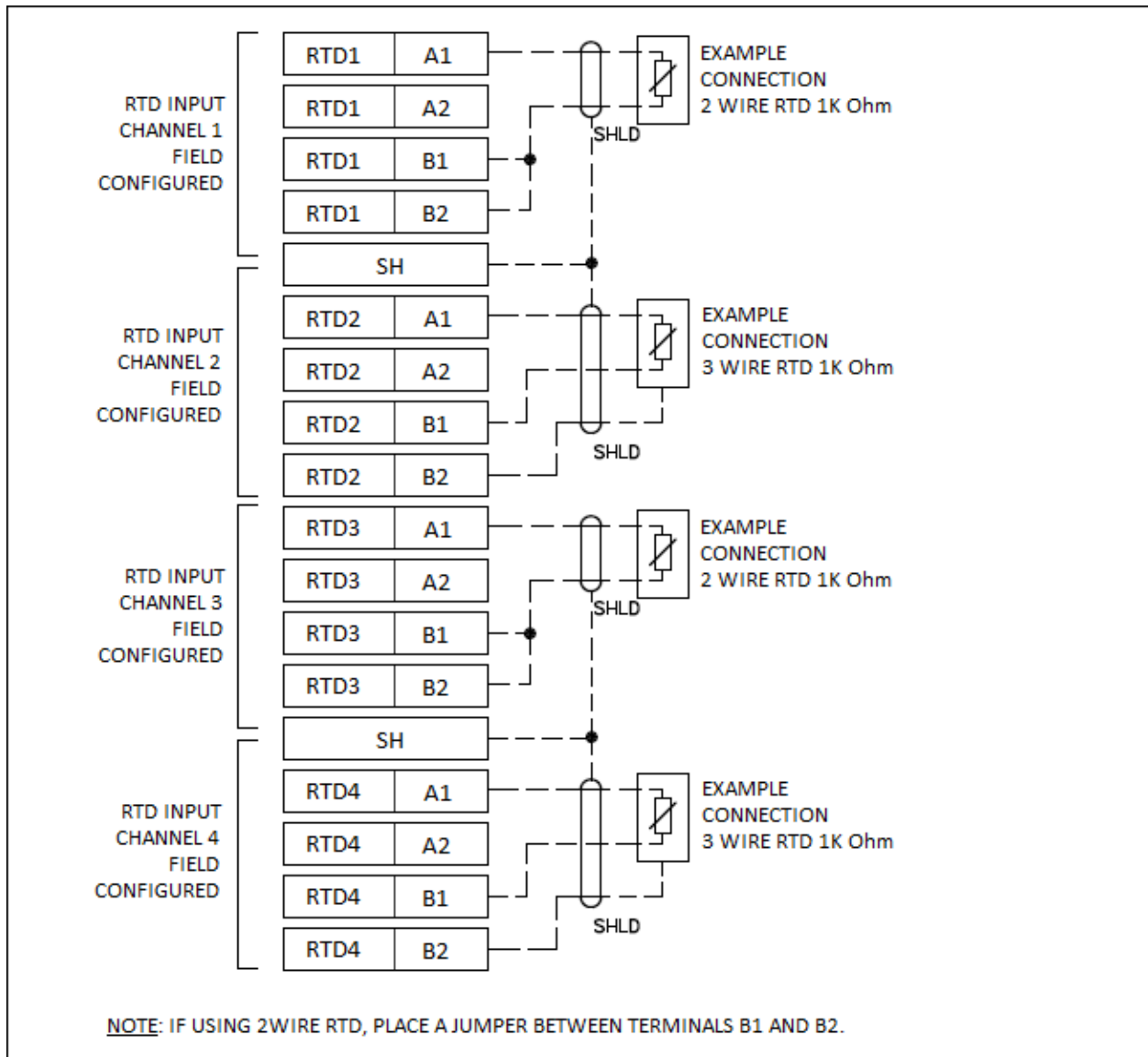

Connections (continued)

RTD Pt or LG-Ni 1000 Ohm input terminals for economizer:

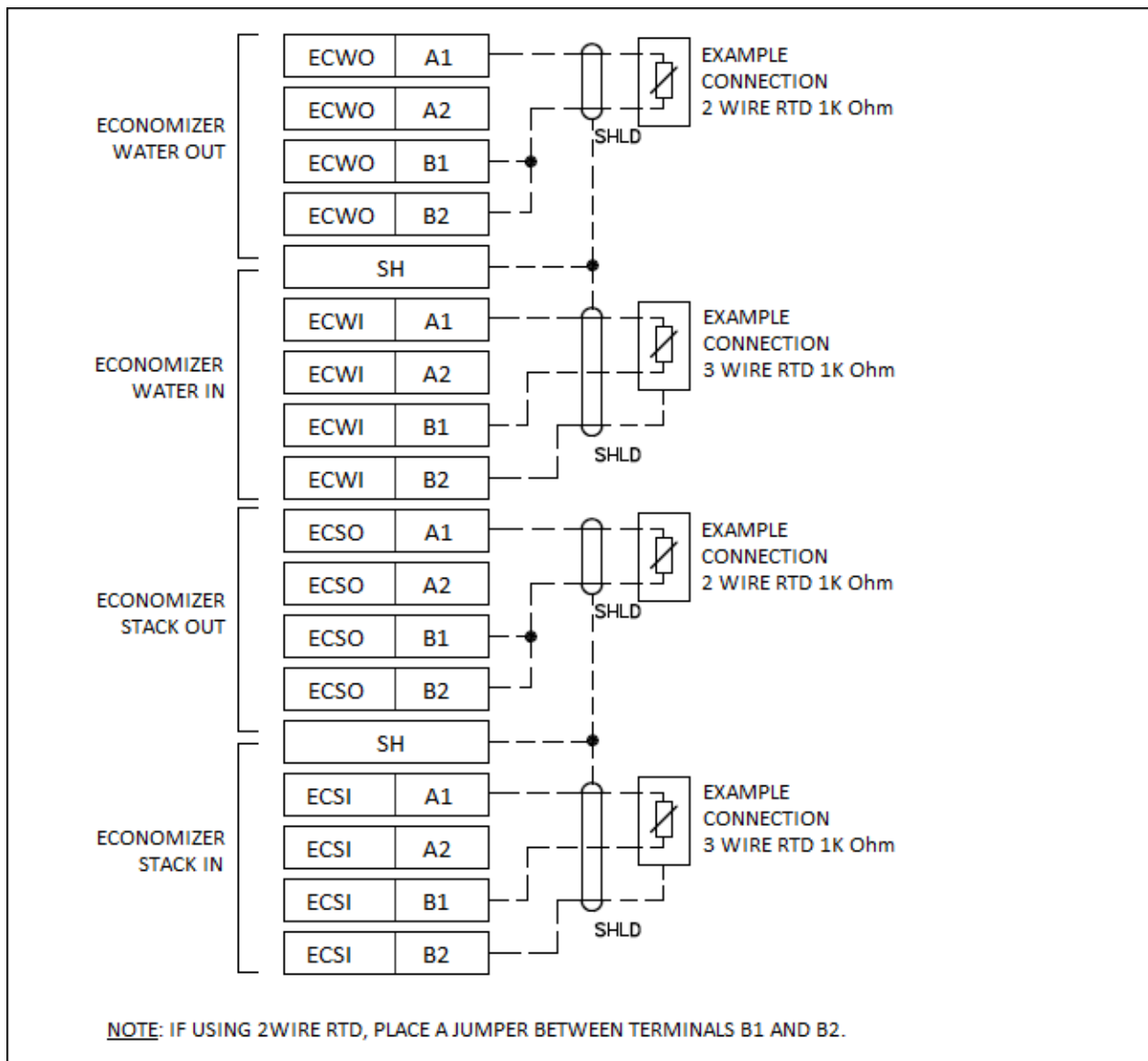

Connections (continued)

Draft Control:

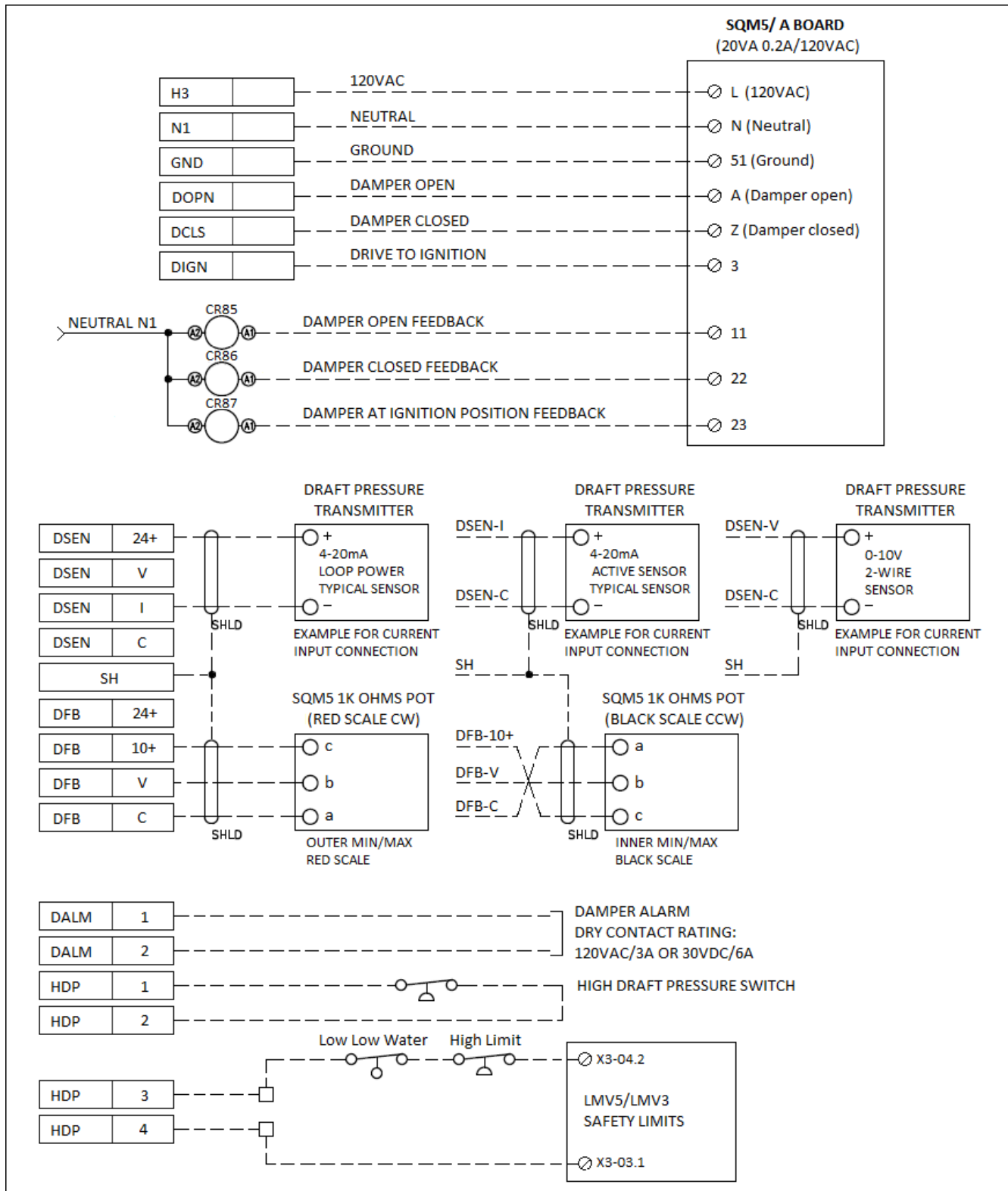

Connections (continued)

RWF55 Water level:

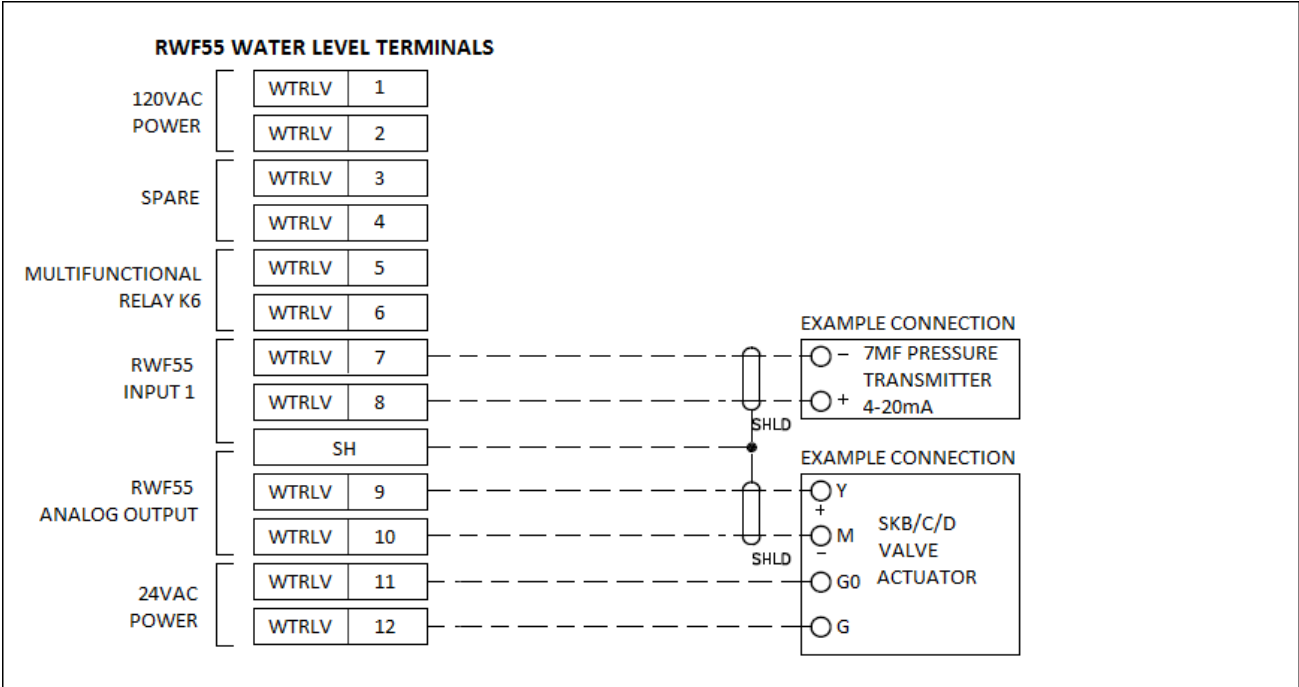

Connections (continued)

RWF55 Load Control with LMV3x:

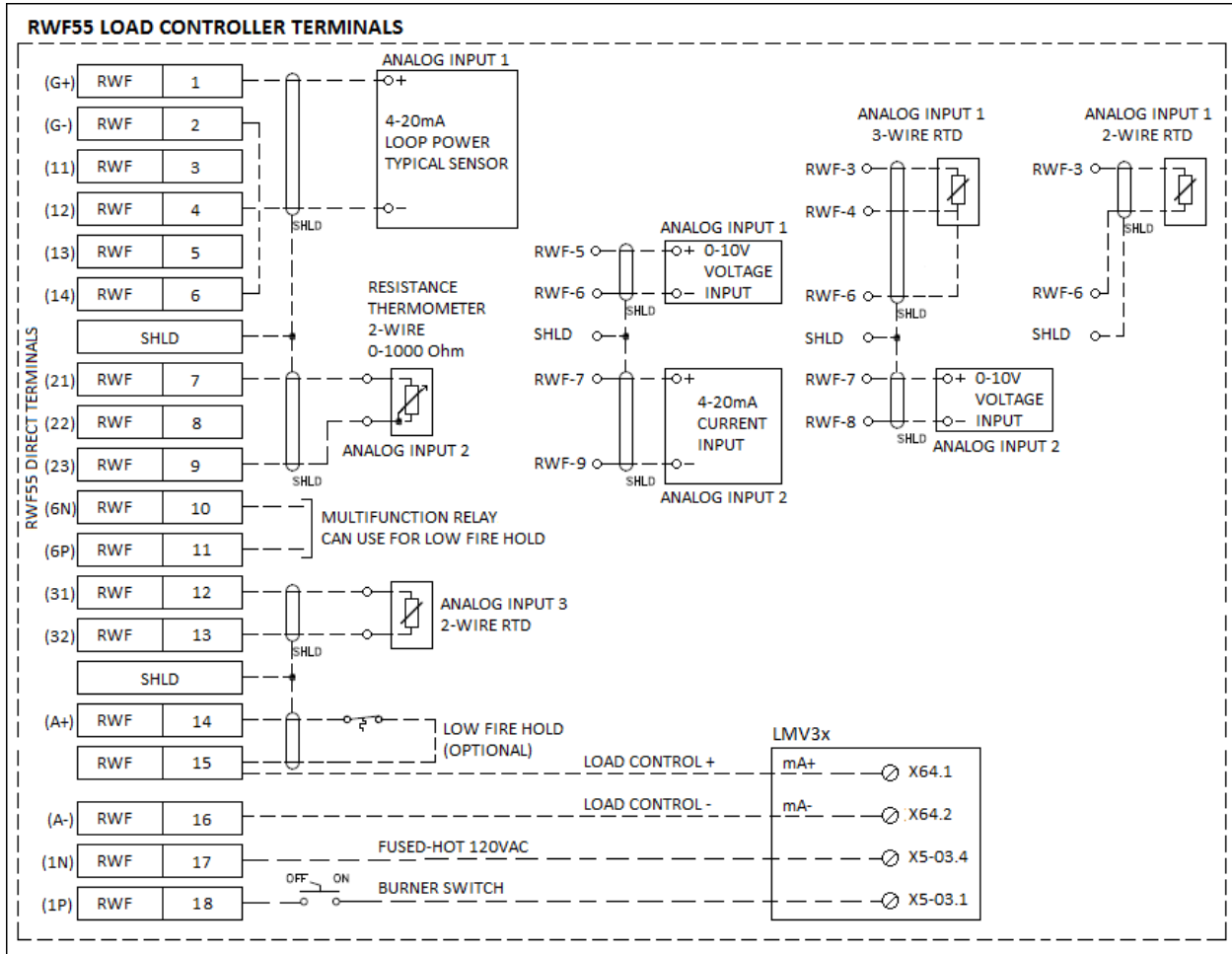

Connections (continued)

RWF55 Load Control with LMV51.040:

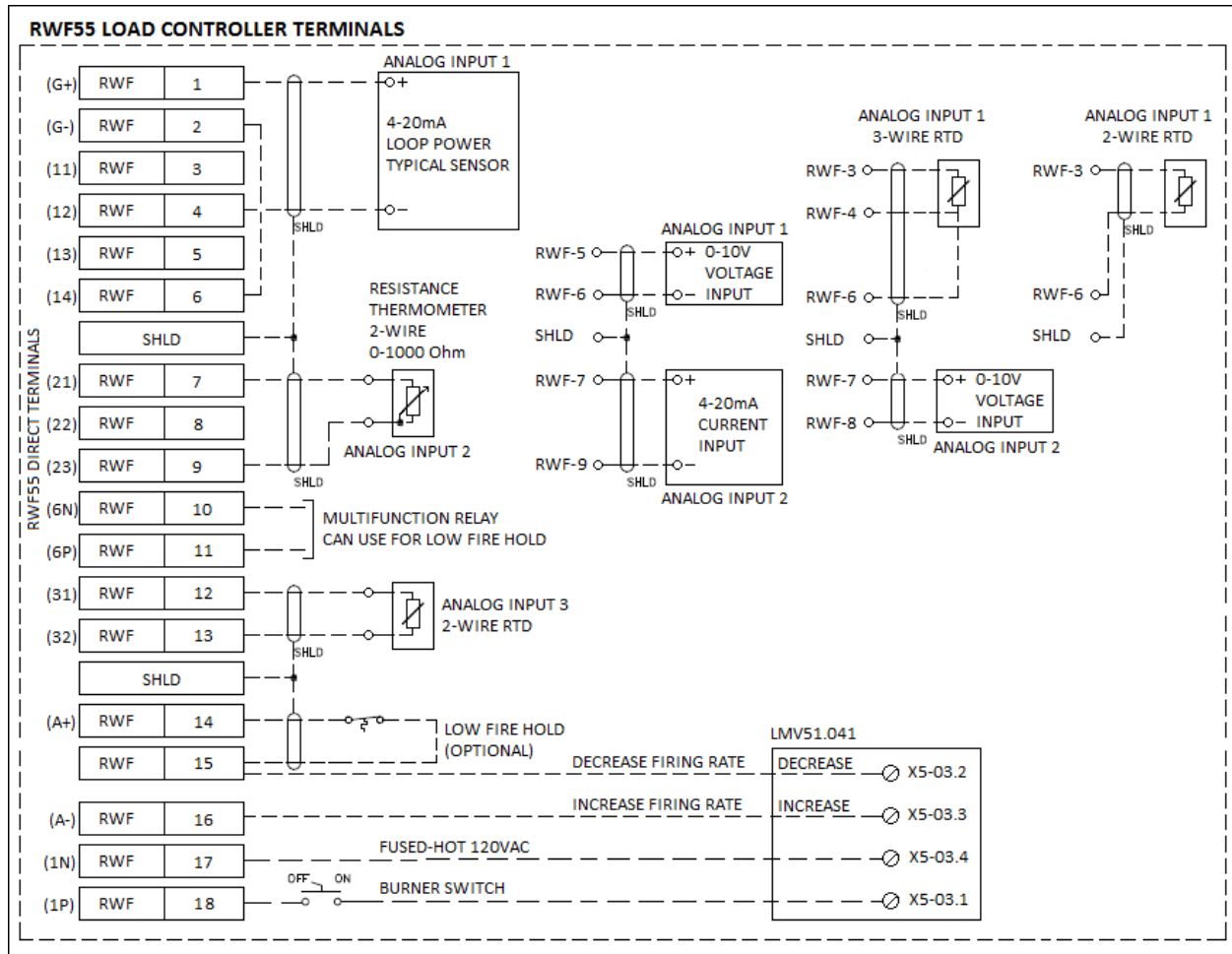

Connections (continued)

RWF55 Load Control only:

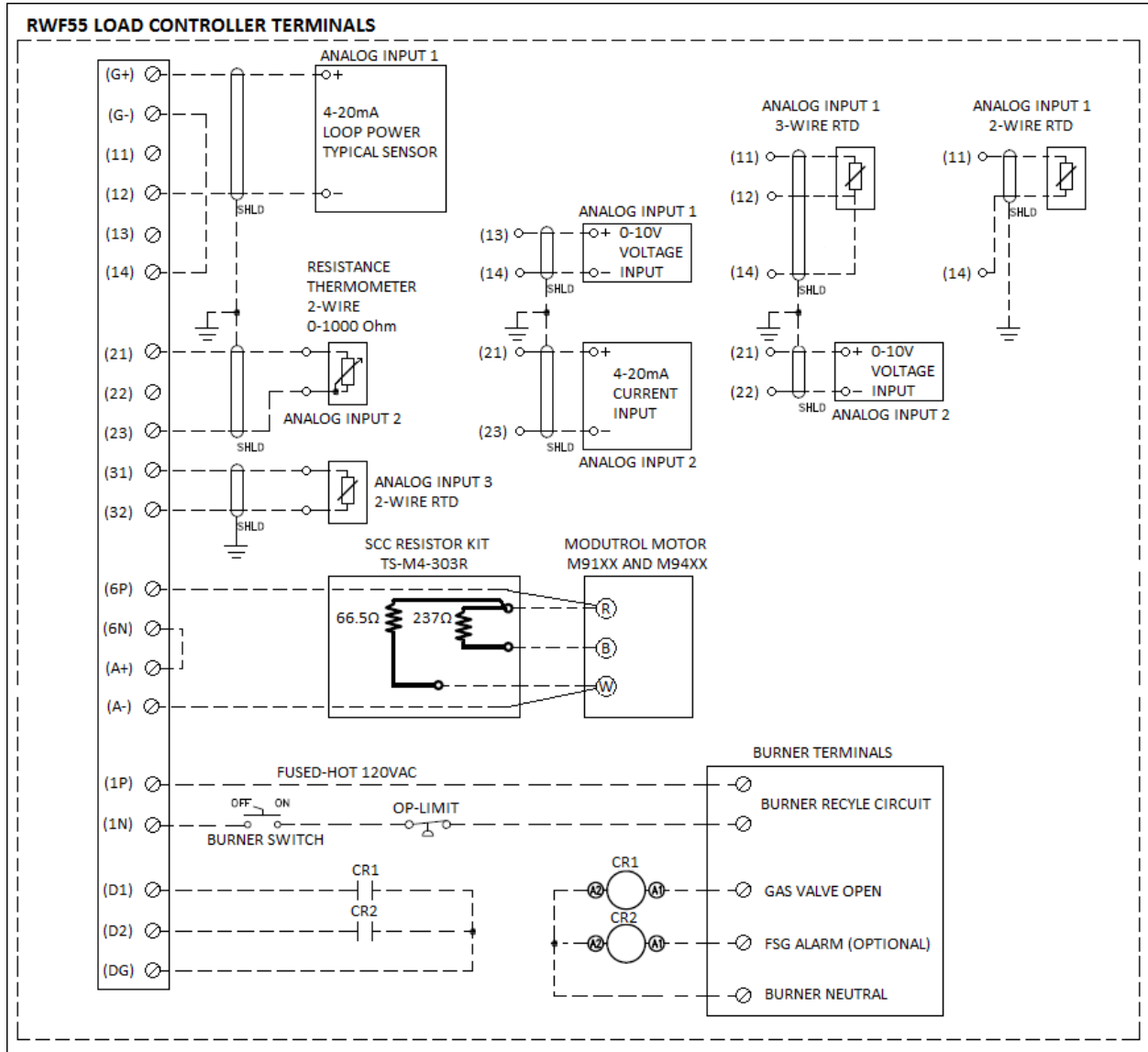

Manual Reset Warrick Relay LWCO

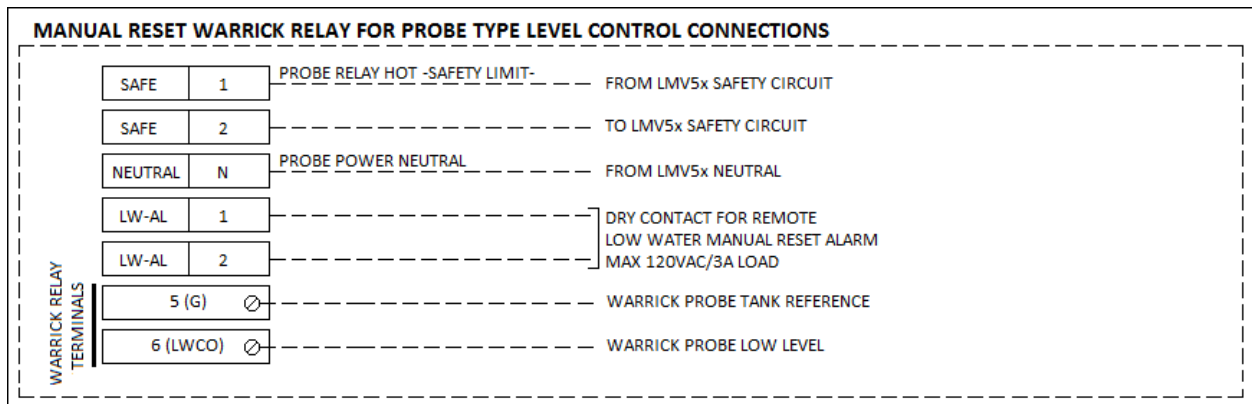

Connections (continued)

BMS Connections

Standard Modbus TCP/IP:

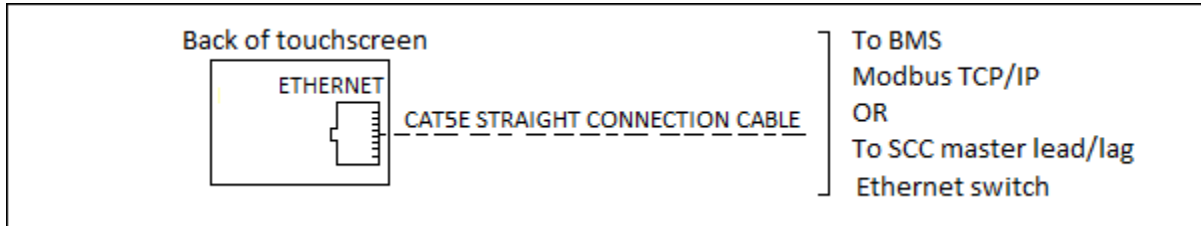

Standard Modbus TCP/IP with PLC annunciation:

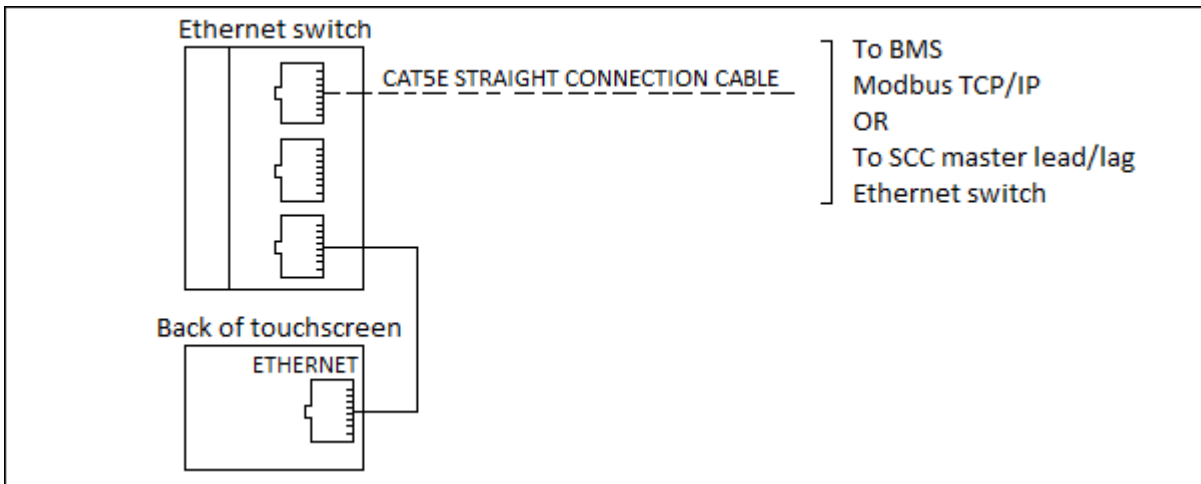

BACnet/IP or Ethernet/IP:

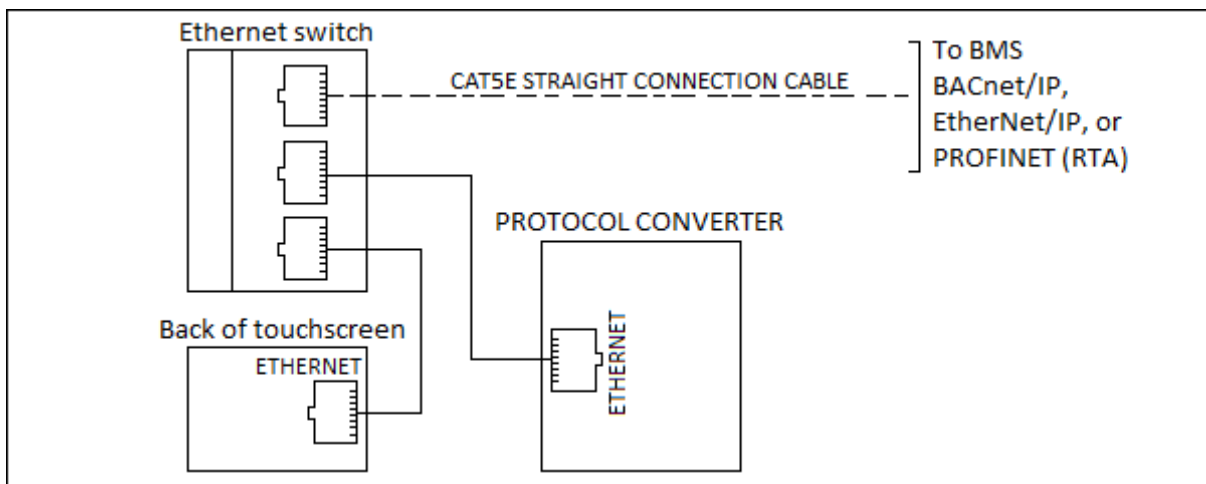

Connections (continued)

PROFIBUS:

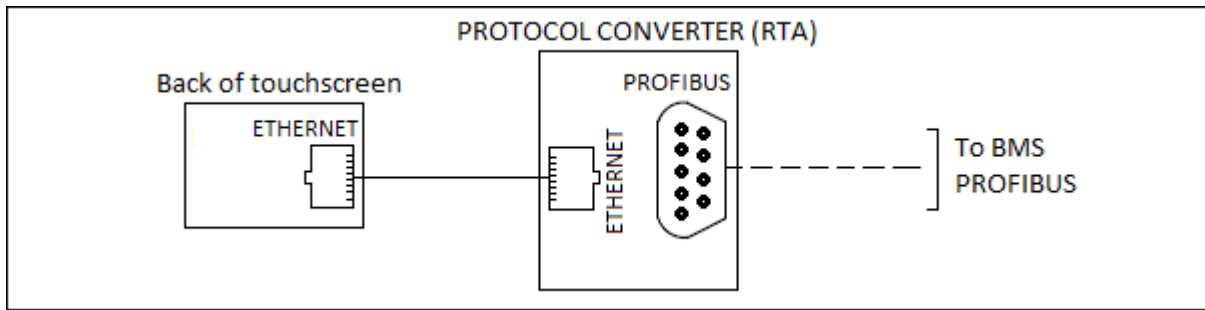

LonWorks:

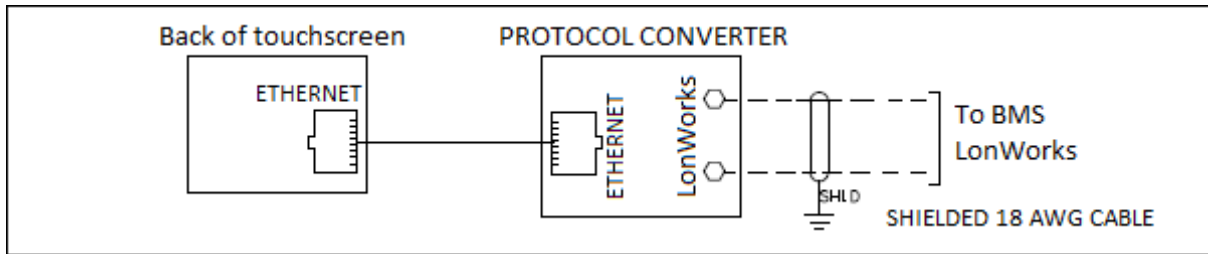

ProtoNode N2 Johnson Metasys, BACnet MS/TP or Modbus RTU:

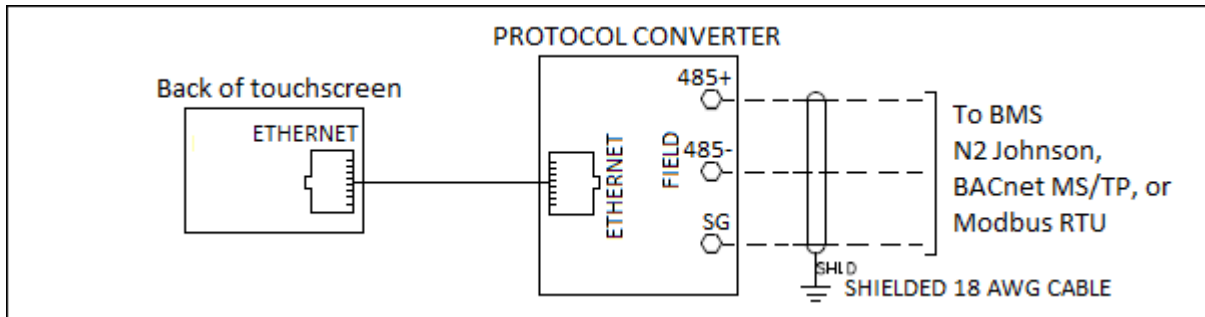

ProtoAir N2 Johnson Metasys, BACnet MS/TP or Modbus RTU:

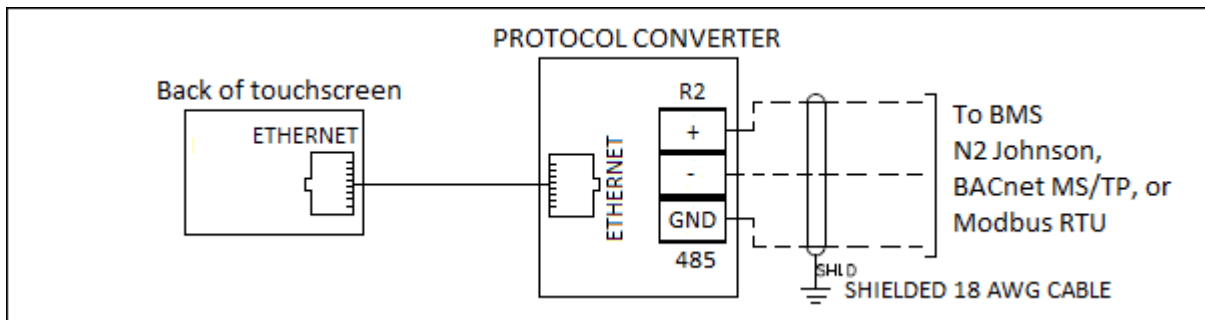

Parts Descriptions

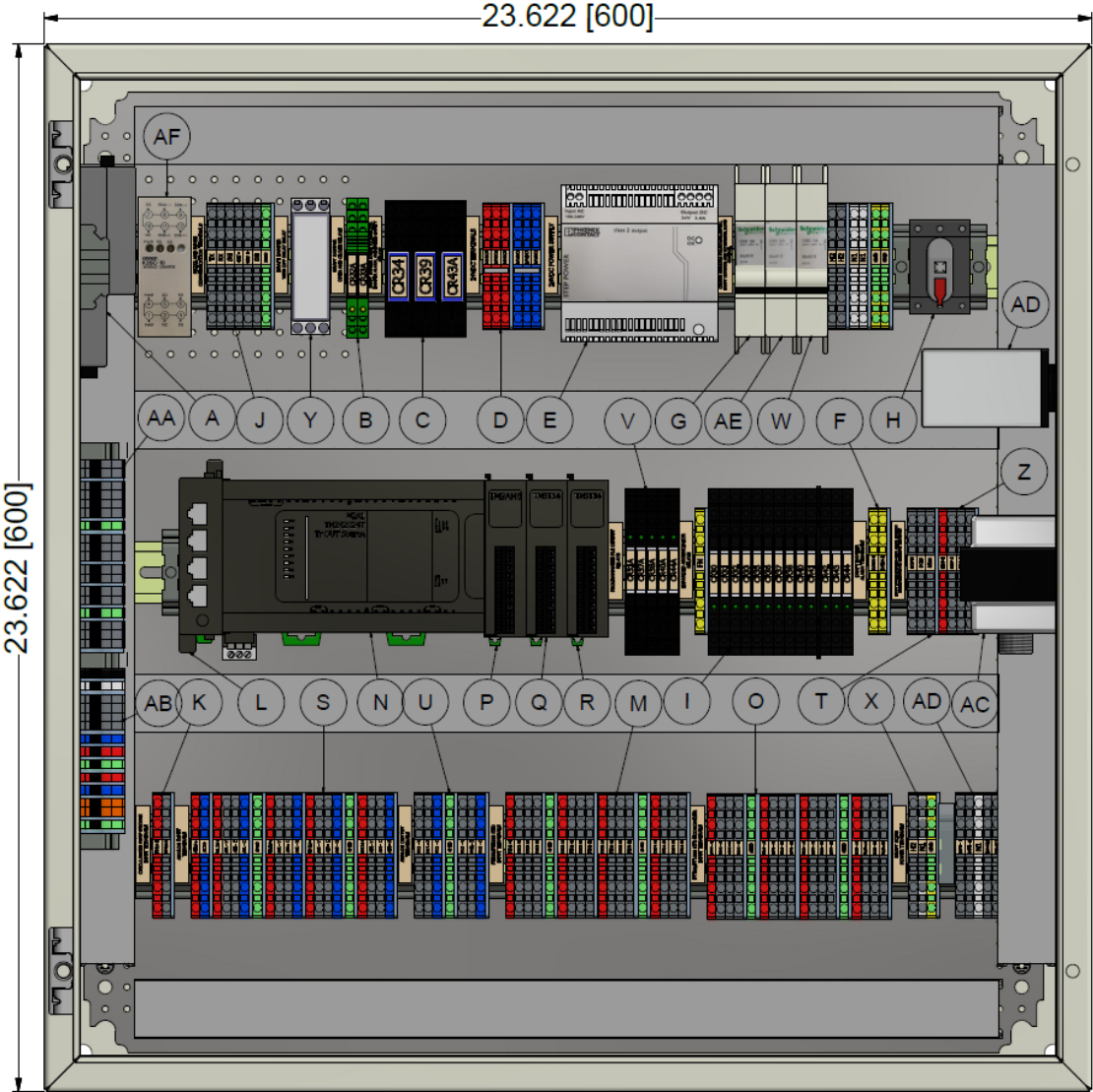

Parts Descriptions (continued)

A	BMS Communication BACnet/LON/N2/RTU	BMS communication other than Modbus TCP/IP
B	Solid State Relays (Draft Control Option)	Draft damper open and close relays
C	DPDT Relays (Draft Control Option Only)	Draft control ignition permissive Draft control damper drive open on failure Draft control alarm
D	24 VDC Terminals	24 VDC connections
E	24 VDC Power Supply	24VDC source
F	Field Terminals (Yellow)	Field outputs and control terminals
G	3 Amps Circuit Breaker	120 VAC power isolation
H	16 Amp Non-Fused Disconnect	120 VAC disconnect, only when installed in SCC enclosure
I	120 VAC SPDT Relays	Burner / Boiler alarms ,13 annunciation relays, 3 relays for draft(optional), first in first out.
J	Modbus RS232 and RS485 Terminals	Field Modbus connections to LMV5/LMV3/RWF55/ RWF10
K	Circulating Pump Proven	Circulating pump proven field terminals
L	Ethernet Switch	Ethernet connection to touchscreen, and master panel, and/or BMS
M	RTD Inputs Terminals	Field wiring, general purpose temperature monitoring
N	PLC	Microprocessor based logic controller
O	RTD Inputs Terminals	Economizer temperature monitoring field terminals
P	Analog Input Module	0-10V/4-20mA flow, pressure, temperature, DP pressure monitoring, and high and low signal alarms

Q	RTD Input Module	Designated for general purpose temperature monitoring of high and low signal alarms
R	RTD Input Module	Economizer temperature monitoring water in, water out, stack in, and stack out
S	Analog Input Terminals	field wiring terminals for flow, pressure, temperature, DP pressure, 4-20mA, or 0-10 Volt inputs.
T	Draft Mod Motor Field Terminals	Ignition permissive Damper drive open Alarm actuator interconnecting terminals
U	Analog Output Terminals	Monitored value via 4-20 mA signal
V	SPDT Relays	Hot water only circulating pump control General alarm Monitored status digital output 1 Monitored status digital output 2 PLC health always on
W	1 Amp Circuit Breaker	Draft control 120 VAC power isolation
X	120VAC Power Terminals	SQM5 actuator 120VAC power terminals
Y	Off Delay Timer	Draft control, high pressure boiler shutoff, delay timer
Z	Draft Control Terminals	LMV interconnect safety loop and high pressure switch terminals
AA	RWF55 Load Controller Terminals	External load controller for LMV5 or LMV3 systems 4-20mA and 0-10V inputs and outputs
AB	RWF55 Load Controller Feedwater Terminals	Feedwater controller 4-20mA and 0-10V inputs and outputs
AC	24VAC TRANSFORMER	Control power for SKB/C or D feedwater actuators
AD	Warrick Relay and connecting terminals	Manual reset LWCO Warrick relay for Probe connections
AE	2 Amp Circuit Breaker	120 VAC power isolation for feedwater
AF	RS232 TO RS485 Converter	Communication converter used for distances greater than 15ft
AG	Analog Inputs	Analog Input terminals for draft

Touchscreen Dimensions and Cut-outs

Dimensions in inches; millimeters in brackets

3" and 6" Touchscreen

TS-6xxx-xxx

Installation:

Cutout required as shown below

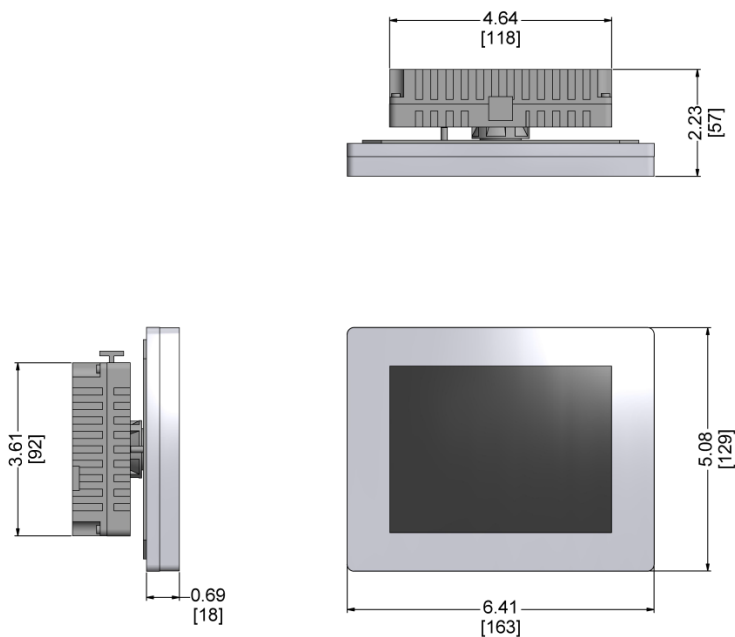
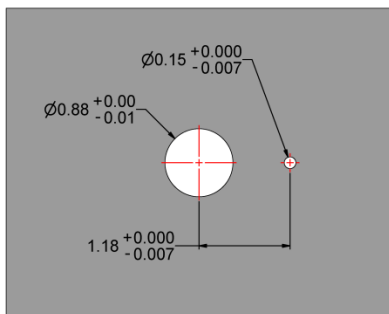

10" Touchscreen

TS-0xxx-xxx

Installation:

Cutout required as shown below

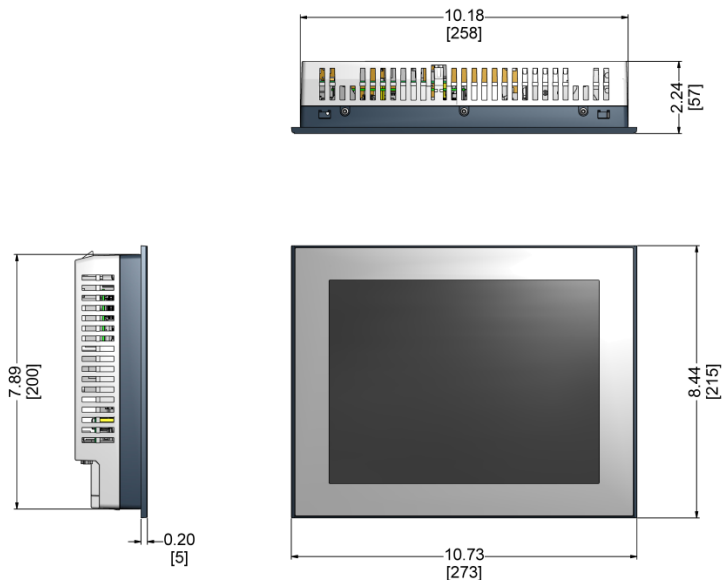
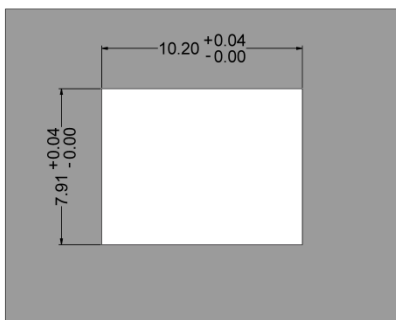

Kits Dimensions

TS-xXXS-xxx

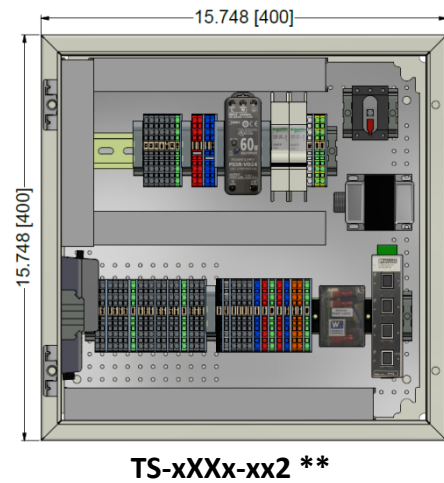
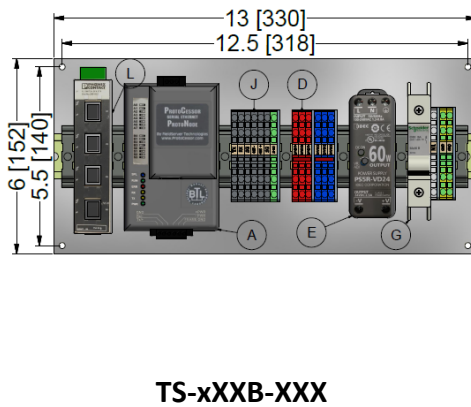
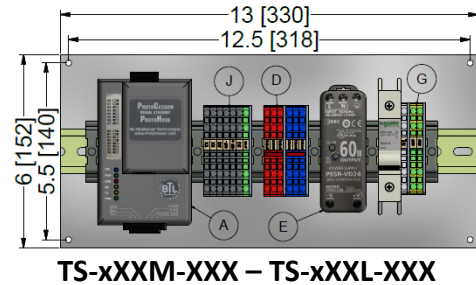
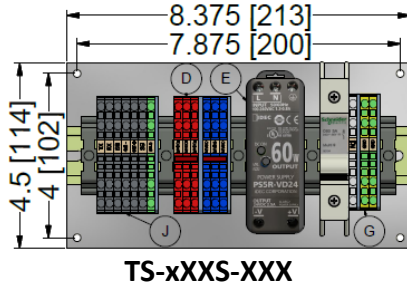

** Kit In Enclosure	RWF55 Load Control Terminals (AA)	RWF55 Feed Water Terminals (AB)	24VAC Transformer for Feed Water (AC)	2 Amp Circuit Breaker (AE)
TS-xXXx-xxX				
TS-xXXx-xxL	y			y
TS-xXXx-xxW		y	y	y
TS-xXXx-xx2	y	y	y	y

Note **: Small “x” in the part number above denotes: Any selection
 Large “X” denotes: No selection is available
 “y” denotes: Yes for the table option

Note: Terminal Letters correspond with page 29 descriptions

Kits Dimensions (continued)

TS-JXXX-xxx

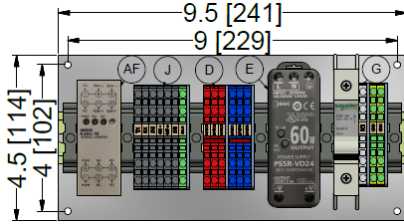

TS-JXXS-XXX

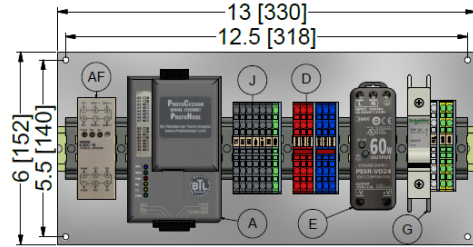

TS-JXXM-XXX – TS-JXXL-XXX

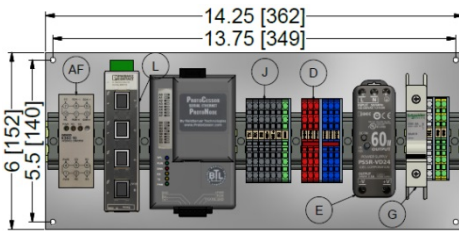

TS-JXXB-XXX

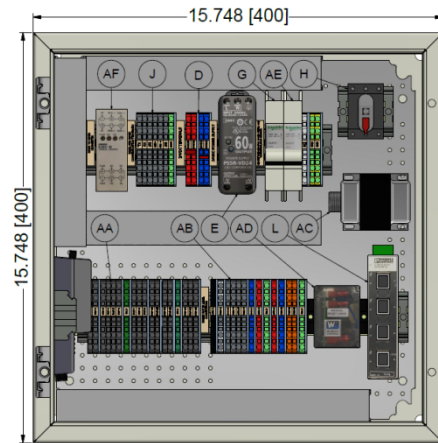

TS-JXXx-xx2 **

** Kit In Enclosure	RWF55 Load Control Terminals (AA)	RWF55 Feed Water Terminals (AB)	24VAC Transformer for Feed Water (AC)	2 Amp Circuit Breaker (AE)
TS-JXXx-xxX				
TS-JXXx-xxL				y
TS-JXXx-xxW		y	y	y
TS-JXXx-xx2	y	y	y	y

Note: (AF) RS232 to RS485 converter used only in TS-Jxxx-xxx

Note: Terminal Letters correspond with page 29 descriptions

Kits Dimensions (continued)

TS-xXXx-xxx

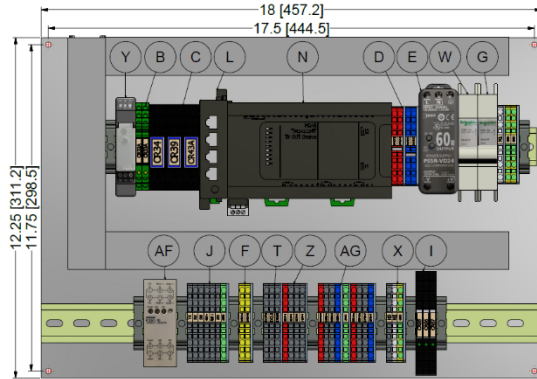

TS-xDXS-XXX

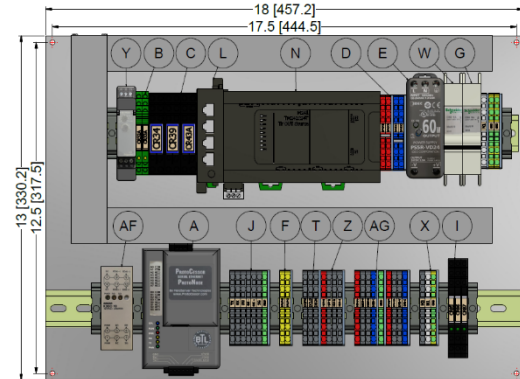

TS-xDXx-XXX – TS-xDXL-XXX

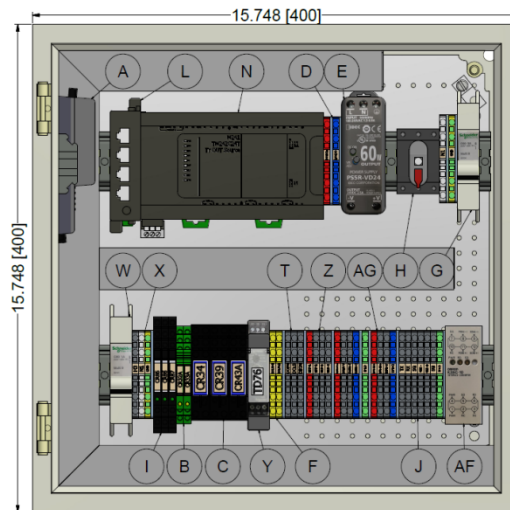

TS-xDXx-xx2

** Kit In Enclosure	RWF55 Load Control Terminals (AA)	RWF55 Feed Water Terminals (AB)	24VAC Transformer for Feed Water (AC)	2 Amp Circuit Breaker (AE)
TS-xXXx-xxX				
TS-xXXx-xxL	y			y
TS-xXXx-xxW		y	y	y
TS-xXX1x-xx2	y	y	y	y

Note: Layouts include optional draft controls with TS-xDxx-xxx

Note: (AF) RS232 to RS485 converter used only with TS-Jxxx-xxx

Note: Terminal Letters correspond with page 29 descriptions

Kits Dimensions (continued)

TS-xX1x-xxx

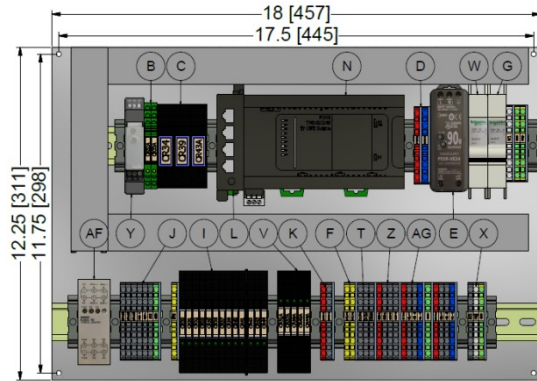

TS-xD1S-XXX

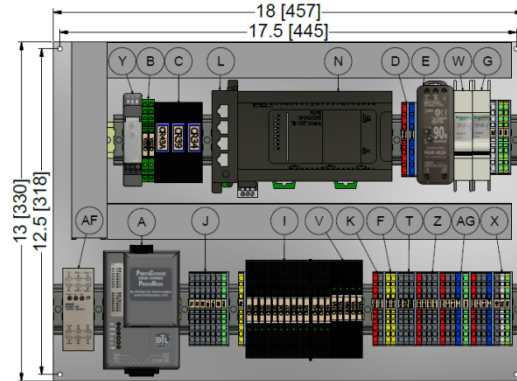

TS-xD1x-XXX – TS-xD1L-XXX

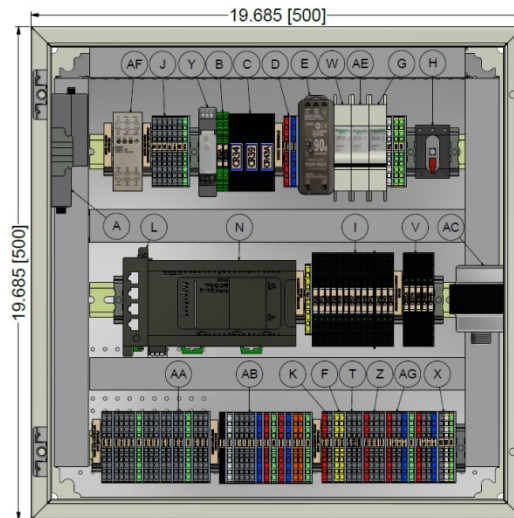

TS-xD1x-xx2

** Kit In Enclosure	RWF55 Load Control Terminals (AA)	RWF55 Feed Water Terminals (AB)	24VAC Transformer for Feed Water (AC)	2 Amp Circuit Breaker (AE)
TS-xX1x-xxX				
TS-xX1x-xxL	y			y
TS-xX1x-xxW		y	y	y
TS-xX1x-xx2	y	y	y	y

Note: Layouts include optional draft controls with TS-xDxx-xxx

Note: (AF) RS232 to RS485 converter used only with TS-Jxxx-xxx

Note: Terminal Letters correspond with page 29 descriptions

Kits Dimensions (continued)

TS-xX2x-xxx

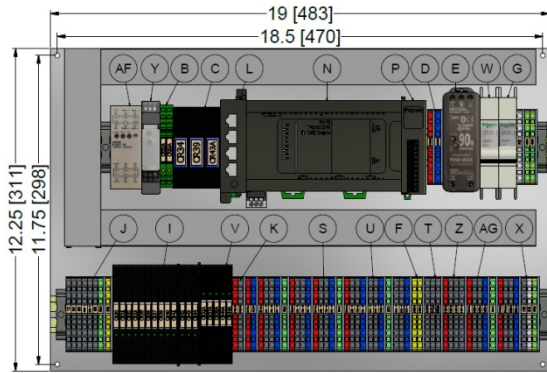

TS-xD2S-XXX

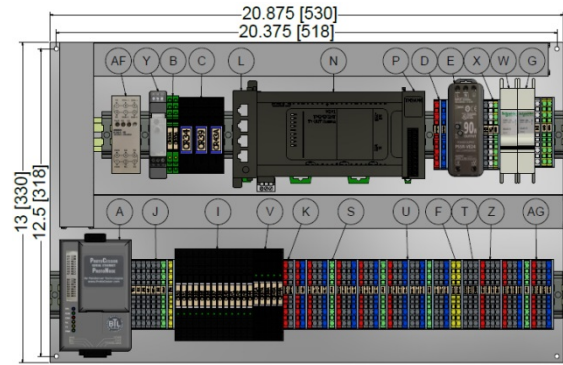

TS-xD2x-XXX

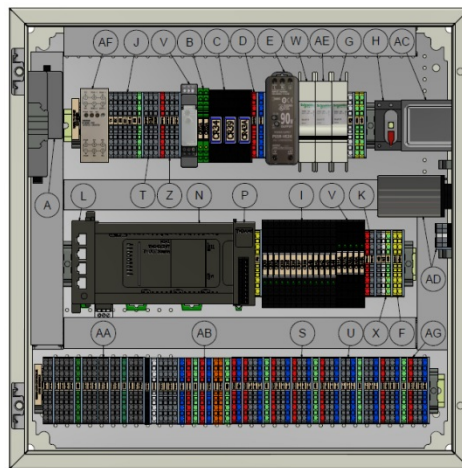

TS-xD2x-xx2

** Kit In Enclosure	RWF55 Load Control Terminals (AA)	RWF55 Feed Water Terminals (AB)	24VAC Transformer for Feed Water (AC)	2 Amp Circuit Breaker (AE)
TS-xX2X-xxX				
TS-xX2X-xxL	y			y
TS-xX2X-xxW		y	y	y
TS-xX2X-xx2	y	y	y	y

Note: Layouts include optional draft controls with TS-xDxx-xxx

Note: (AF) RS232 to RS485 converter used only with TS-Jxxx-xxx

Note: Terminal Letters correspond with page 29 descriptions

Kits Dimensions (continued)

TS-xX3x-xxx

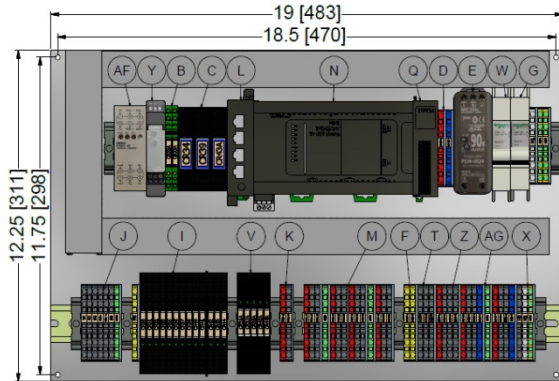

TS-xD3S-XXX

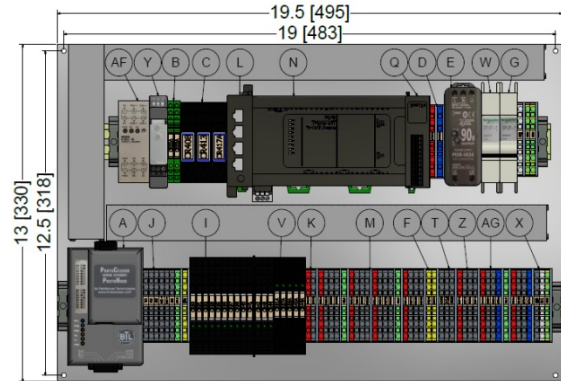

TS-xD3x-XXX

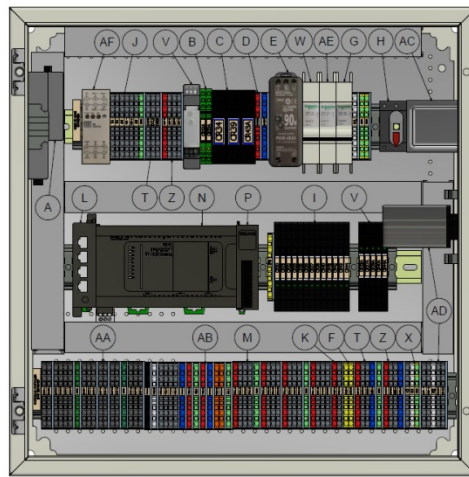

TS-xD3x-xx2

** Kit In Enclosure	RWF55 Load Control Terminals (AA)	RWF55 Feed Water Terminals (AB)	24VAC Transformer for Feed Water (AC)	2 Amp Circuit Breaker (AE)
TS-xX3X-xxX				
TS-xX3X-xxL	y			y
TS-xX3X-xxW		y	y	y
TS-xX3X-xx2	y	y	y	y

Note: Layouts include optional draft controls with TS-xDxx-xxx

Note: (AF) RS232 to RS485 converter used only with TS-Jxxx-xxx

Note: Terminal Letters correspond with page 29 descriptions

Kits Dimensions (continued)

TS-xX4x-xxx

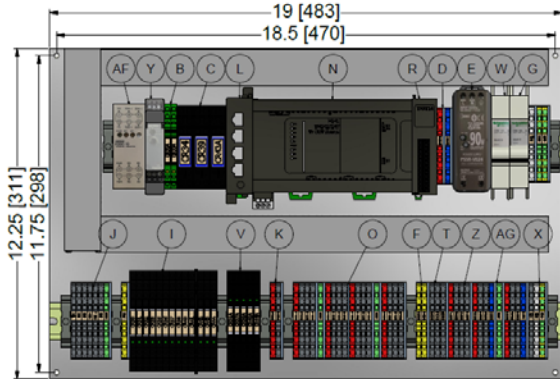

TS-xX4S-XXX

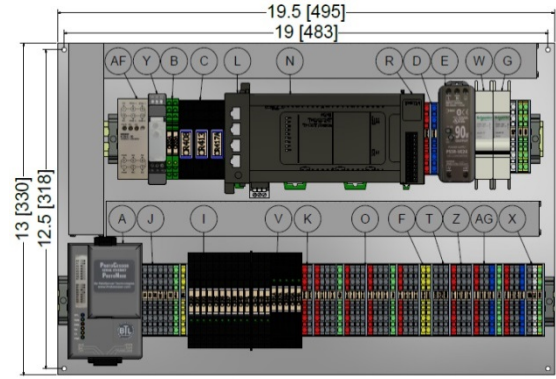

TS-xX4x-XXX

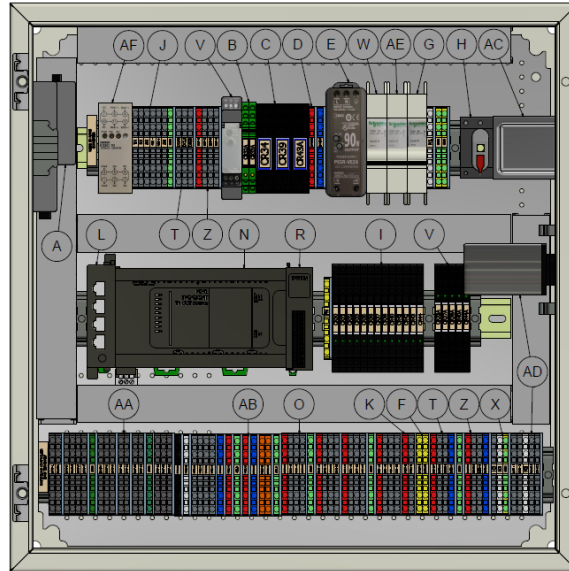

TS-xD4x-xx2

** Kit In Enclosure	RWF55 Load Control Terminals (AA)	RWF55 Feed Water Terminals (AB)	24VAC Transformer for Feed Water (AC)	2 Amp Circuit Breaker (AE)
TS-xX4X-xxX				
TS-xX4X-xxL	y			y
TS-xX4X-xxW		y	y	y
TS-xX4X-xx2	y	y	y	y

Note: Layouts include optional draft controls with TS-xDxx-xxx

Note: (AF) RS232 to RS485 converter used only with TS-Jxxx-xxx

Note: Terminal Letters correspond with page 29 descriptions

Kits Dimensions (continued)

TS-xX5x-xxx

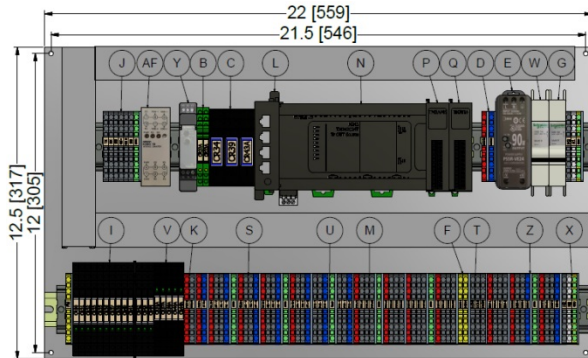

TS-xD5S-XXX

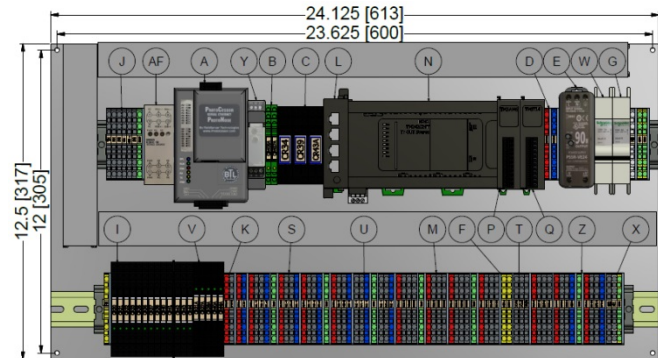

TS-xD5x-XXX

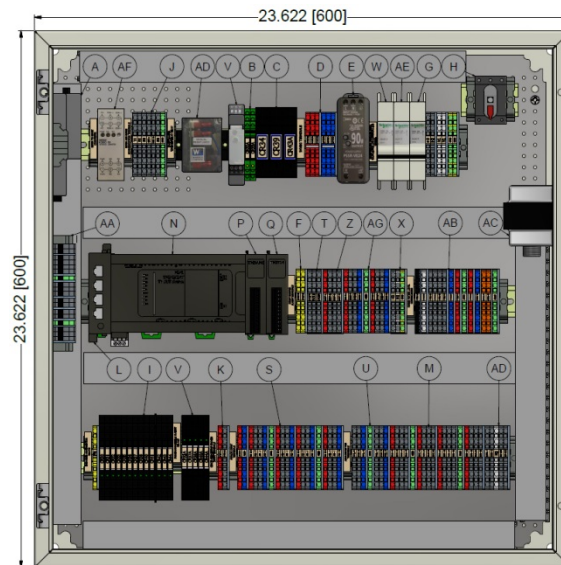

TS-xD5x-xx2

** Kit In Enclosure	RWF55 Load Control Terminals (AA)	RWF55 Feed Water Terminals (AB)	24VAC Transformer for Feed Water (AC)	2 Amp Circuit Breaker (AE)
TS-xX5X-xxX				
TS-xX5X-xxL	y			y
TS-xX5X-xxW		y	y	y
TS-xX5X-xx2	y	y	y	y

Note: Layouts include optional draft controls with TS-xDxx-xxx

Note: (AF) RS232 to RS485 converter used only with TS-Jxxx-xxx

Note: Terminal Letters correspond with page 29 descriptions

Kits Dimensions (continued)

TS-xX6x-xxx

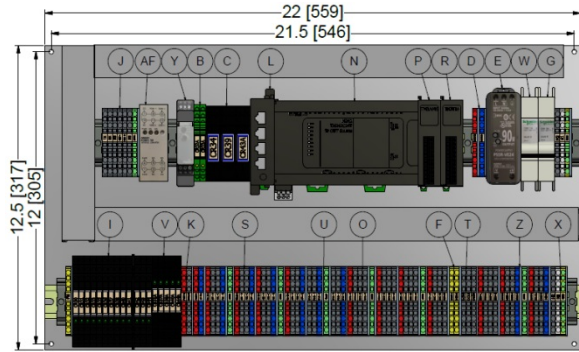

TS-xD6S-XXX

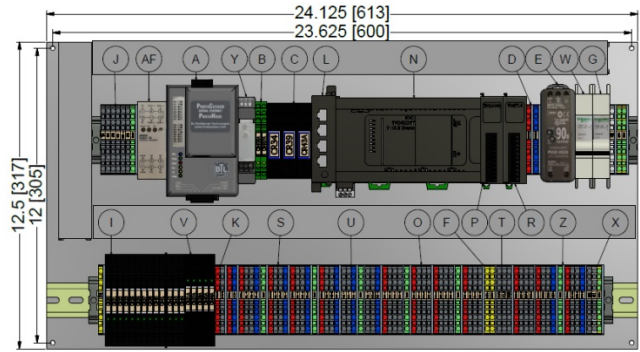

TS-xD6x-XXX

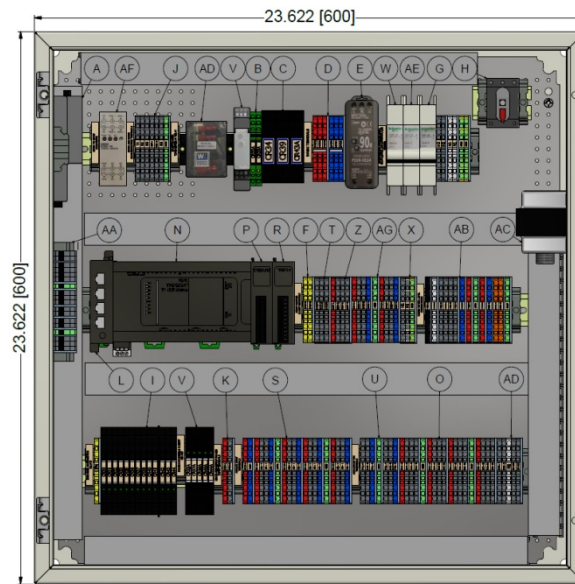

TS-xD6x-xx2

** Kit In Enclosure	RWF55 Load Control Terminals (AA)	RWF55 Feed Water Terminals (AB)	24VAC Transformer for Feed Water (AC)	2 Amp Circuit Breaker (AE)
TS-xX6X-xxX				
TS-xX6X-xxL	y			y
TS-xX6X-xxW		y	y	y
TS-xX6X-xx2	y	y	y	y

Note: Layouts include optional draft controls with TS-xDxx-xxx

Note: (AF) RS232 to RS485 converter used only with TS-Jxxx-xxx

Note: Terminal Letters correspond with page 29 descriptions

Kits Dimensions (continued)

TS-xX7x-xxx

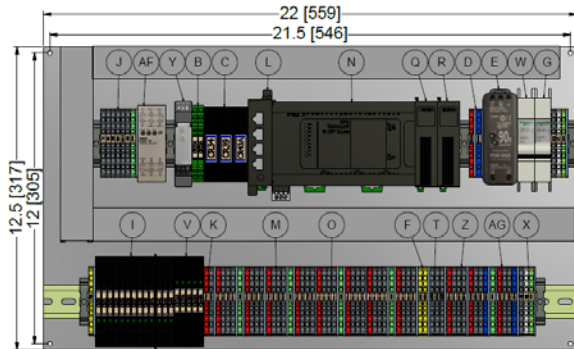

TS-xX7S-XXX

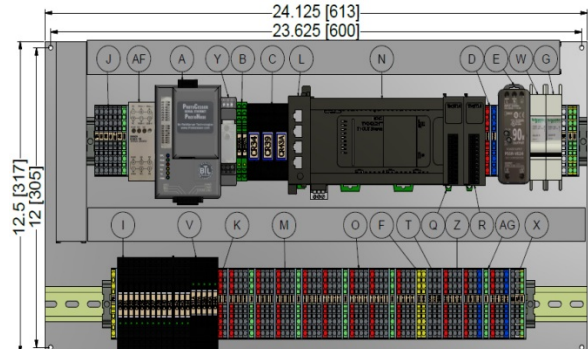

TS-xD7x-XXX

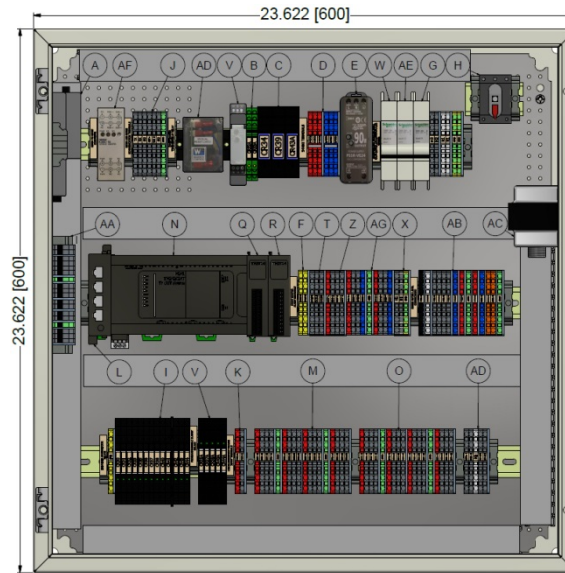

TS-xD7x-xx2

** Kit In Enclosure	RWF55 Load Control Terminals (AA)	RWF55 Feed Water Terminals (AB)	24VAC Transformer for Feed Water (AC)	2 Amp Circuit Breaker (AE)
TS-xX7X-xxX				
TS-xX7X-xxL	y			y
TS-xX7X-xxW		y	y	y
TS-xX7X-xx2	y	y	y	y

Note: Layouts include optional draft controls with TS-xDxx-xxx

Note: (AF) RS232 to RS485 converter used only in TS-Jxxx-xxx

Note: Terminal Letters correspond with page 29 descriptions

Kits Dimensions (continued)

TS-xX8x-xxx

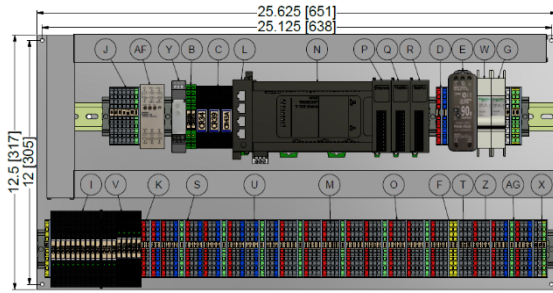

TS-xX8S-XXX

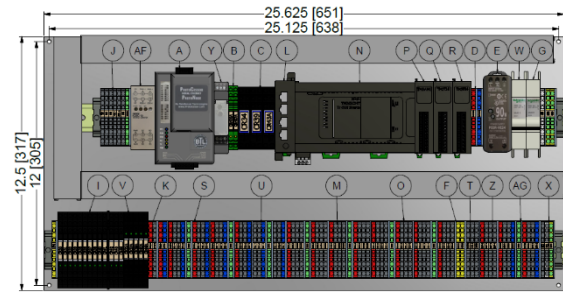

TS-xD8x-XXX

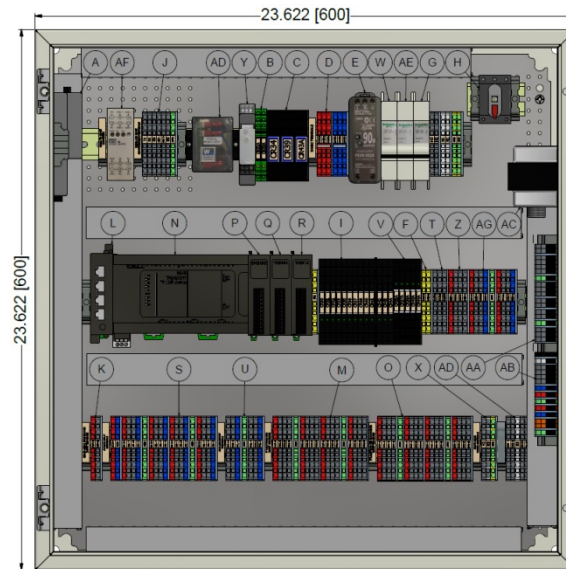

TS-xX8x-xx2 **

** Kit In Enclosure	RWF55 Load Control Terminals (AA)	RWF55 Feed Water Terminals (AB)	24VAC Transformer for Feed Water (AC)	2 Amp Circuit Breaker (AE)
TS-xX8X-xxX				
TS-xX8X-xxL	y			y
TS-xX8X-xxW		y	y	y
TS-xX8X-xx2	y	y	y	y

Note: Layouts include optional draft controls with TS-xDxx-xxx

Note: (AF) RS232 to RS485 converter used only in TS-Jxxx-xxx

Note: Terminal Letters correspond with page 29 descriptions

24"X 24" X 10" Enclosure Dimensions

Dimensions in inches; millimeters in brackets

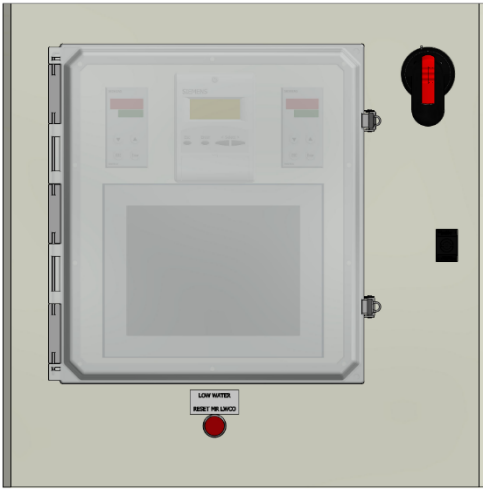

TS-xx5x-252 - TS-xx5x-452
TS-xx6x-252 - TS-xx6x-452
TS-xx7x-252 - TS-xx7x-452
TS-xx8x-252 - TS-xx8x-452

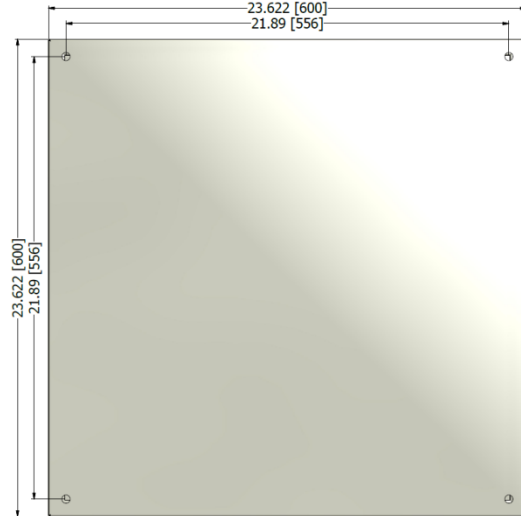

TS-xx5x-xxx
TS-xx6x-xxx
TS-xx7x-xxx
TS-xx8x-xxx

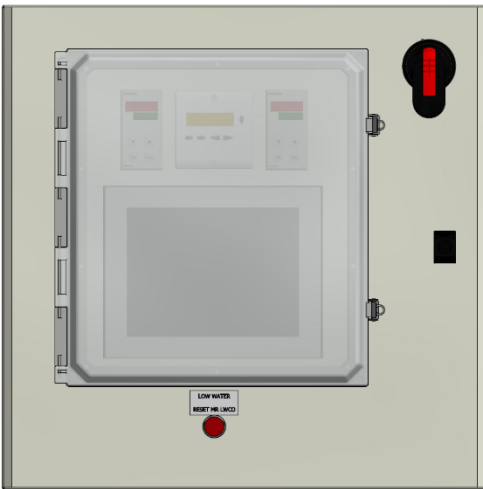

TS-xx5x-232 - TS-xx5x-432
TS-xx6x-232 - TS-xx6x-432
TS-xx7x-232 - TS-xx7x-432
TS-xx8x-232 - TS-xx8x-432

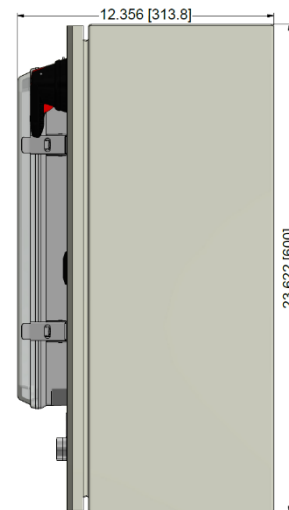

TS-xx5x-232 - TS-xx5x-452
TS-xx6x-232 - TS-xx6x-452
TS-xx7x-232 - TS-xx7x-452
TS-xx8-232 - TS-xx8x-452

16"X 16" X 8" Enclosure Dimensions

For TS-xXXx-1xx and for xXXB-1xx

Dimensions in inches; millimeters in brackets

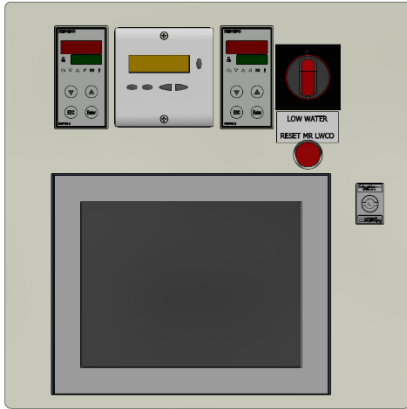

TS-0XXx-132

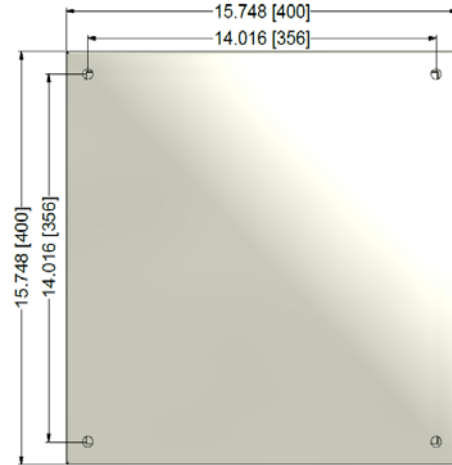

TS-xXXx-xxx

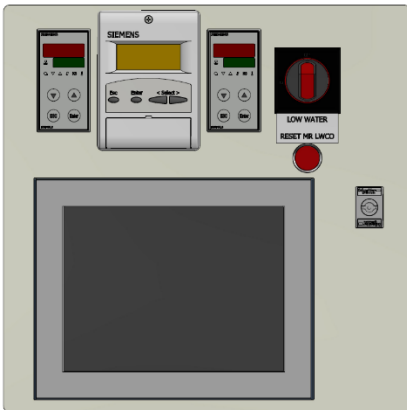

TS-0XXx-152

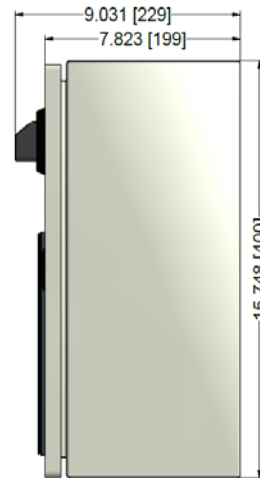

TS-xXXx-1xx

20"X 20" X 10" Enclosure Dimensions

For TS-xXX-1xx and for xXXB-1xx

Dimensions in inches; millimeters in brackets

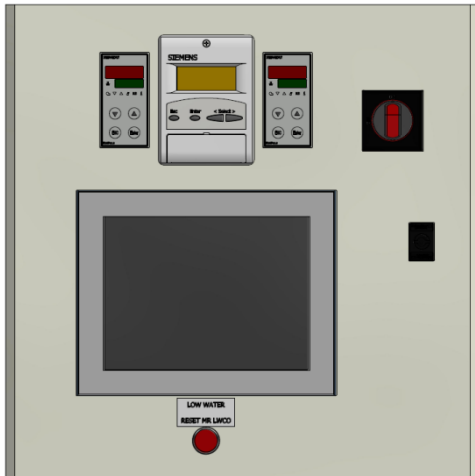

TS-xX1x-152
TS-xX2x-152_ TS-xX3x-152
TS-xX4x-152

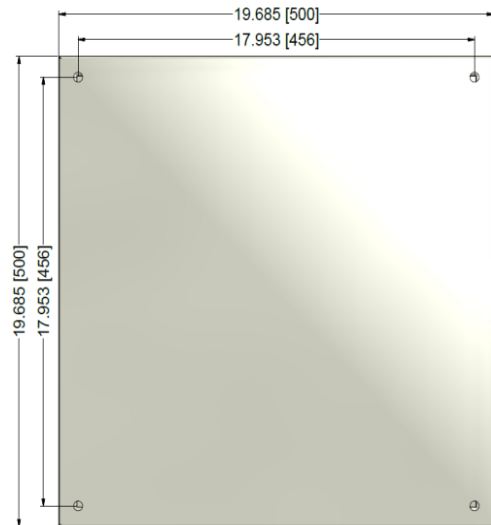

TS-xX1x-xxx
TS-xX2x-1xx_ TS-xX3x-1xx
TS-xX4x-1xx

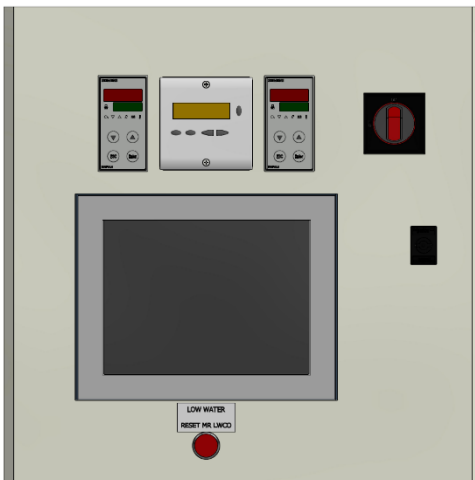

TS-xX1x-132
TS-xX2x-132_ TS-xX3x-132
TS-xX4x-132

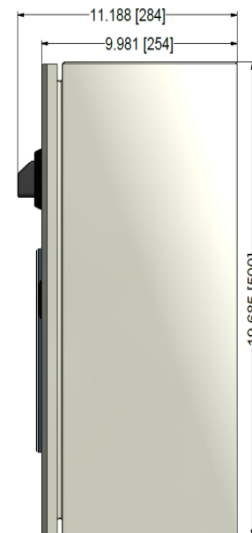

TS-xX1x-1xx
TS-xX2x-1xx_ TS-xX3x-1xx
TS-xX4x-1xx

Information in this publication is based on current specifications. The company reserves the right to make changes in specifications and models as design improvements are introduced. Product or company names mentioned herein may be the trademarks of their respective owners. © 2009 SCC Inc.