

TS Series

TS-CE... Combustion Enclosures with LMV5...

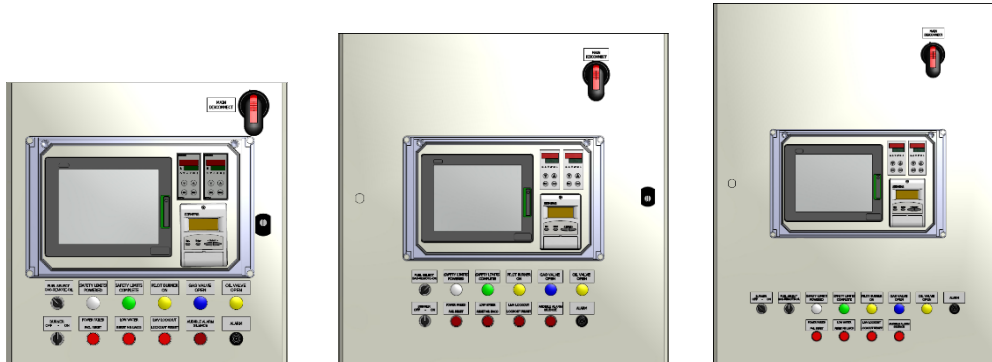

Description

TS-CE... series combustion enclosure with Siemens LMV5 linkageless controller sets the standard for combustion control and monitoring technologies. The preprogrammed touchscreen and optional PLC annunciation packages provide monitoring, configuration flexibility, and simple connectivity to an SCC Master Lead/Lag panel for any boiler and burner/boiler installation. The TS-CE... combustion enclosure also provides easy installation.

The TS-CE... combustion control panels with LMVs provide a common centralized center to monitor and retrieve information, resulting in efficient operation of the burner.

All burner flame safeguard and combustion safety control is performed by the advanced Siemens linkageless controller.

Touchscreen options include Modbus TCP/IP communication to a separate master lead/lag panel, or to a third party BMS, as standard with touchscreens. Optional capability to communicate with building management systems is available via Modbus RTU, RS232 or RS485 connections, Johnson Metasys N2, BACnet MS/TP or BACnet IP, Ethernet/IP, LonWorks, Profinet, and Profibus.

Features

TS-CE... combustion enclosure with LMV52 is UL 508 listed and includes the following:

- 6" or 10" touchscreen option
- LMV51 or LMV52 Siemens linkageless control and flame safeguard
- Backlit AZL52 display
- Control for up to six (6) SQM45/48/91 actuators, up to 5 simultaneously
- Programmable logic controller (PLC)
- Steam or hot water boiler control
- Flame supervision and flame strength monitoring
- UV or IR scanners
- Single or dual fuel
- Oil pump control
- Blower motor control
- Atomizing compressor control
- Lead/lag ready with SCC TS... master lead/lag panel
- VSD control
- Blower motor sensor for motor RPM monitoring
- O₂ trim and monitoring, with LMV52 only
- Efficiency calculation with O₂, with LMV52 only
- Thermal shock protection, PT1000 RTD required for steam boilers
- Low fire hold based on temperature setpoint
- Temperature based stepping start
- Time based stepping start
- Combination of temperature and time based stepping start
- FGR low temperature hold
- Shell water temperature monitoring
- External and proven interlocks
- Actuator position display
- LMV5 lockout and fault history
- Stack temperature monitoring
- Burner operation phase display
- Local touchscreen interface with Siemens LMV.../RWF controllers
- Configurable boiler graphics and field tag information
- LMV... static, fuel, lockout, and error history displayed
- Fuel-Air Ratio control curve displayed on touchscreen
- Alarm history for most recent 250 faults/alarms
- Detailed annunciation of LMV... digital inputs and outputs

- Variable Speed Drive information and setup when preprogrammed VFD provided by SCC Inc.
- Remote setpoint, firing rate, and/or enable the LMV... or RWF... via BMS
- Water level control option and status via RWF55
- Standard or Metric units display
- English or Spanish languages
- Circulating pump, isolation valve control outputs for hydronic boilers
- Expanded annunciator options include:
 - Four (4) analog inputs with field configurable label, span, and type (0-10V, 2-10V, 0-20mA or 4-20mA). Each allows low and high alarm setpoints, with auto or manual reset. Totalization available per minute or per hour.
 - Four (4) 1000 Ohm RTD temperature inputs with field configurable label. Each with low and high alarm setpoints, with auto or manual reset.
 - Two (2) analog outputs with field configurable span and type (0-10V, 2-10V, 0-20mA or 4-20mA). Each allows low and high alarm setpoints, with auto or manual reset. Totalization available per minute or per hour.
 - Two (2) digital outputs with field configurable logic, including on and off delays. Manual or automatic reset.
 - First-out annunciation option including thirteen (13) 120 VAC inputs with field labeling capability.
 - Eight (8) selectable data logging variables stored in CSV format on USB drive.
 - Four (4) selectable variables for trending up to 7 days.
 - Economizer temperature monitoring.
 - Draft control with SQM5 actuator.
 - Connection for two additional RWF55 controllers.
- Screen saver with PV, setpoint, demand, and status
- Standard Modbus TCP/IP to BMS communications
- Additional BMS communication options available
- Email communications and text messaging for up to six (6) recipients include alarms, faults, and screen shots (screen shot viewer via USB)
- Remote monitoring via mobile device (smartphone, tablet, etc.)
- Compatible with SCC Master Panel Lead/Lag system

Application

TS-CE...combustion enclosure panels with LMV5 systems are suited for hot water and steam boilers, with up to 600 in/lb of actuator torque, for single or dual fuel applications.

Standard Components

- LMV5 linkageless parallel positioning flame safeguard
- LMV5 CANbus power supply transformer
- Power fail relay
- System alarm
- Circuit breaker, 3 Amp, single pole
- Circuit breaker, 10 Amp, single pole
- Non-fused disconnect switch
- Burner ON/OFF switch
- Fuel selector switch
- Safety limits powered, white indication light
- Safety limits complete, green indicator light
- Pilot burner ON, yellow indicator light
- Gas valve open, blue indicator light
- Oil valve open, yellow indicator light
- Power fail, red illuminated indicator light with reset push button
- Low water, red illuminated indicator light with reset push button
- LMV lockout, red illuminated indicator light with reset push button
- Alarm reset push button
- Alarm horn
- Gray terminals, general
- White terminals, 120 VAC neutral
- Black terminals, 120 VAC hot
- Red terminals, 24 VDC +
- Blue terminals, 24 VDC -
- Orange terminals, 24 VAC
- Yellow terminals, dry contact powered from second source
- Green non-grounding, shield terminals
- Green/yellow PE terminals

Optional Components

- 6" or 10" touchscreen
- Programmable Logic Controller with additional annunciation inputs
- Second CANbus power transformer fuse protection with fuses and fuse holder
- LWCO manual and auto reset Warrick relays for probe type level control
- Draft control with Siemens SQM5 actuator only
- NEMA 12 or NEMA 4X
- Fan air cooling
- Additional RWF... external load or water level controller
- BMS communication options
- Three phase 480 VAC power option includes the following:
 - Main three phase fused disconnect 30Amps/60Amps/100 Amps
 - VSD three phase fuses and fuse holders
 - Blower motor starter for up to 20hp with overload and built in disconnect
 - Oil motor starter for up to 10hp with overload and built in disconnect
 - Compressor motor starter for up to 20hp with overload and built in disconnect
 - 1000 VA circuit control transformer
- Deaerator/Surge control panels (See TS-3000)
- Master lead/lag control panels (See TS-2000)

Specifications without 3-Phase Power

		With Touchscreen	W/out Touchscreen
Electrical characteristics	Main power	120 VAC	120 VAC
	Frequency	60 Hz	60 Hz
	Component power	24 VDC/VAC	120 VAC
	Power consumption	≤ 960 VA	≤ 740 VA
Operating environment	Operating temperature	32 to 122 °F [0 to 50 °C]	-4 to 140 °F [-20 to 60 °C]
	Humidity	Max. 85% with no condensation	Max. 85% with no condensation

Specifications with 3-Phase Power

		With Touchscreen	W/out Touchscreen
Electrical characteristics	Main power	480 VAC	480 VAC
	Frequency	60 Hz	60 Hz
	Current	≤ 72 Amps	≤ 72 Amps
	Component power	24 VDC/VAC	120 VAC
	Power consumption	≤ 35 KVA	≤ 35 KVA
Operating environment	Operating temperature	32 to 122 °F [0 to 50 °C]	-4 to 140 °F [-20 to 60 °C]
	Humidity	Max. 85% with no condensation	Max. 85% with no condensation

Connections

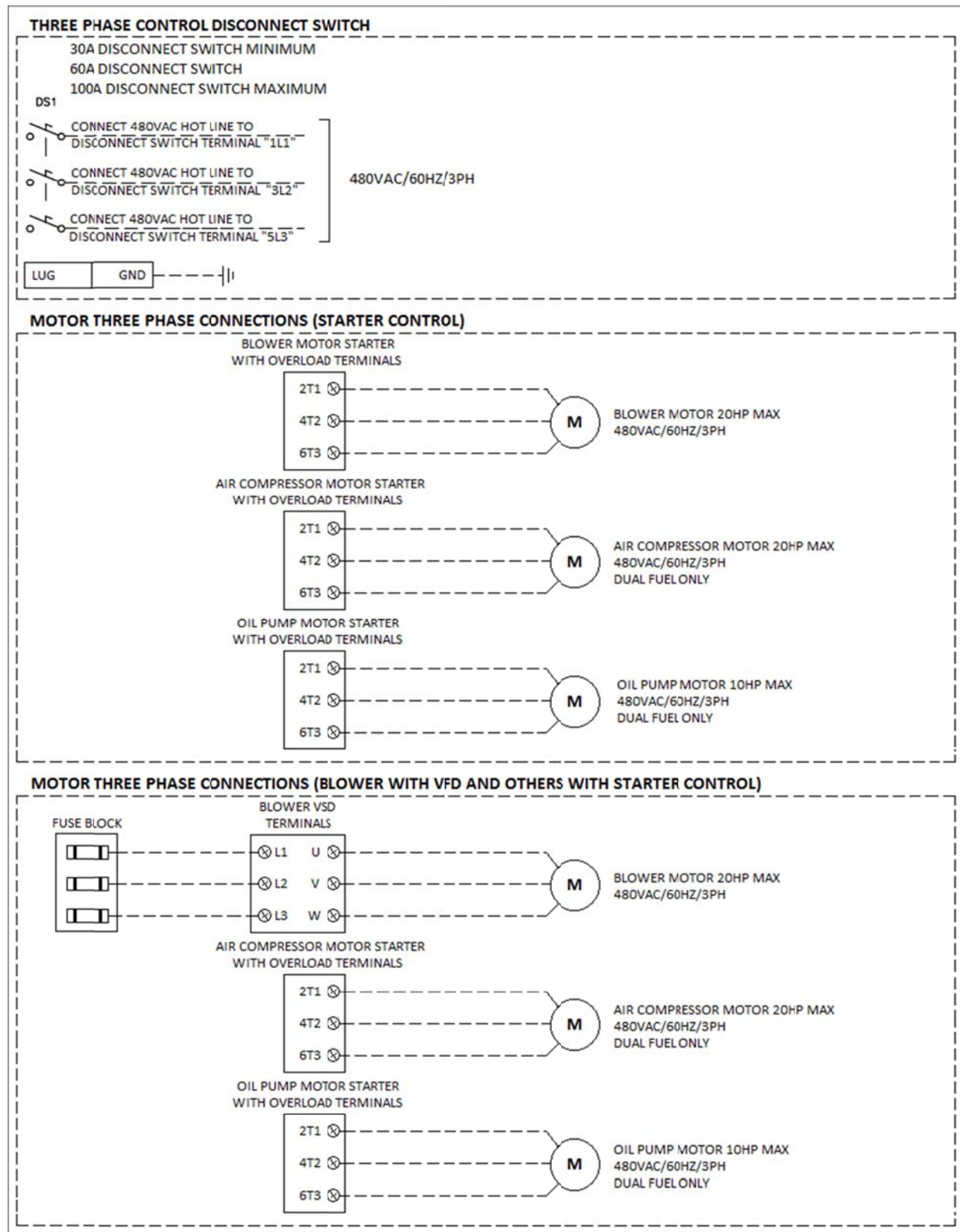

Connections (continued)

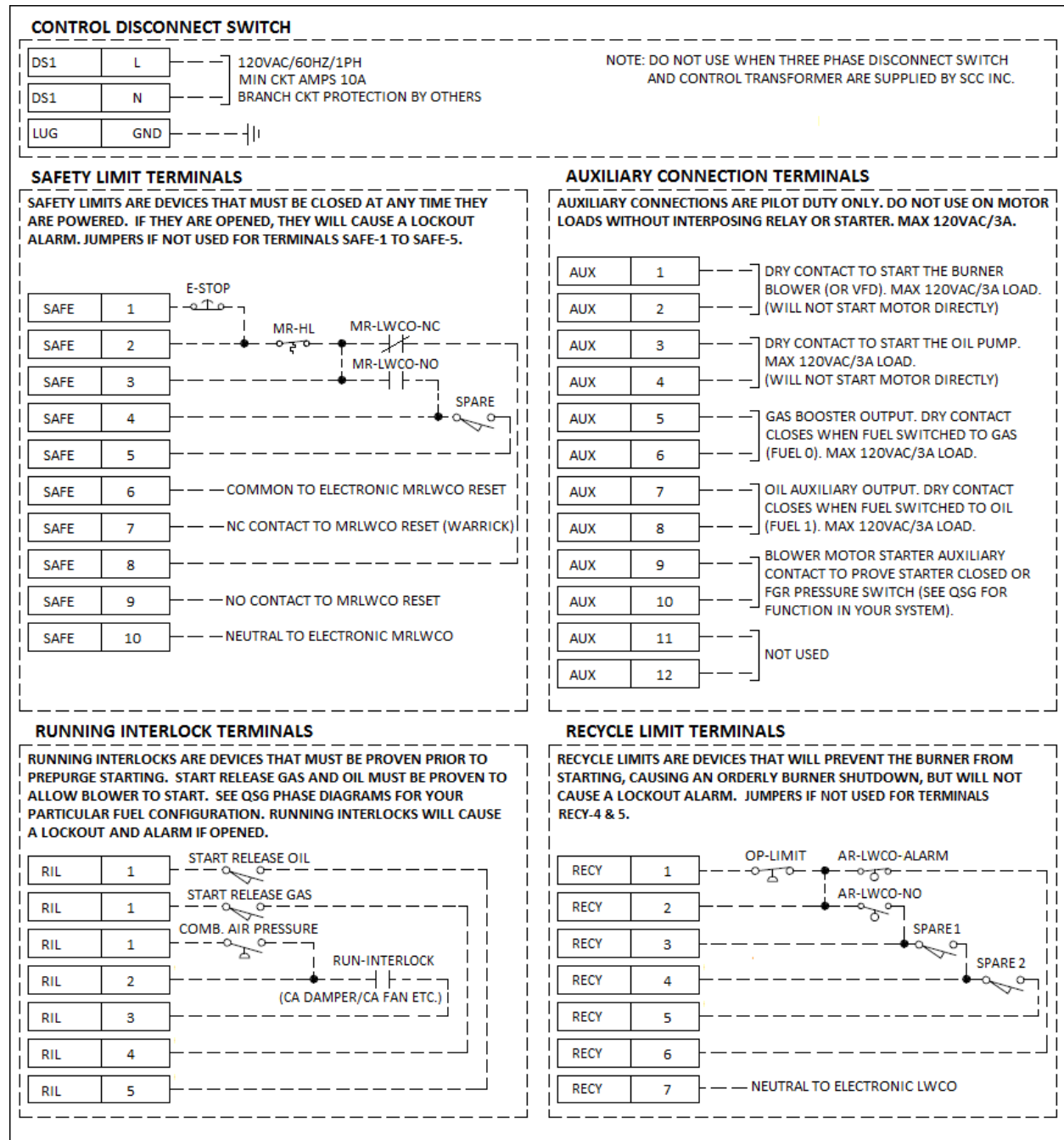

Connections (continued)

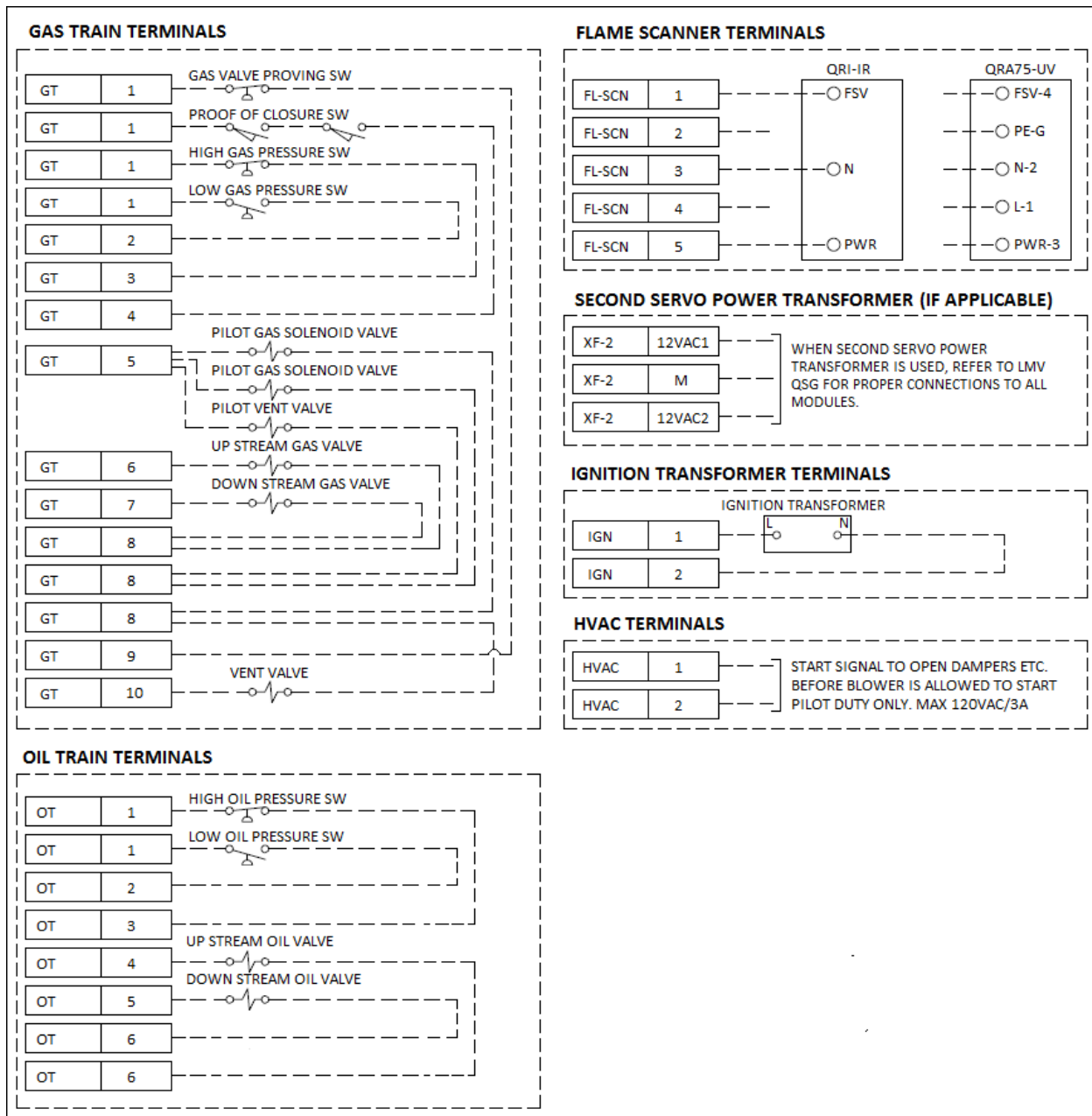

Connections (continued)

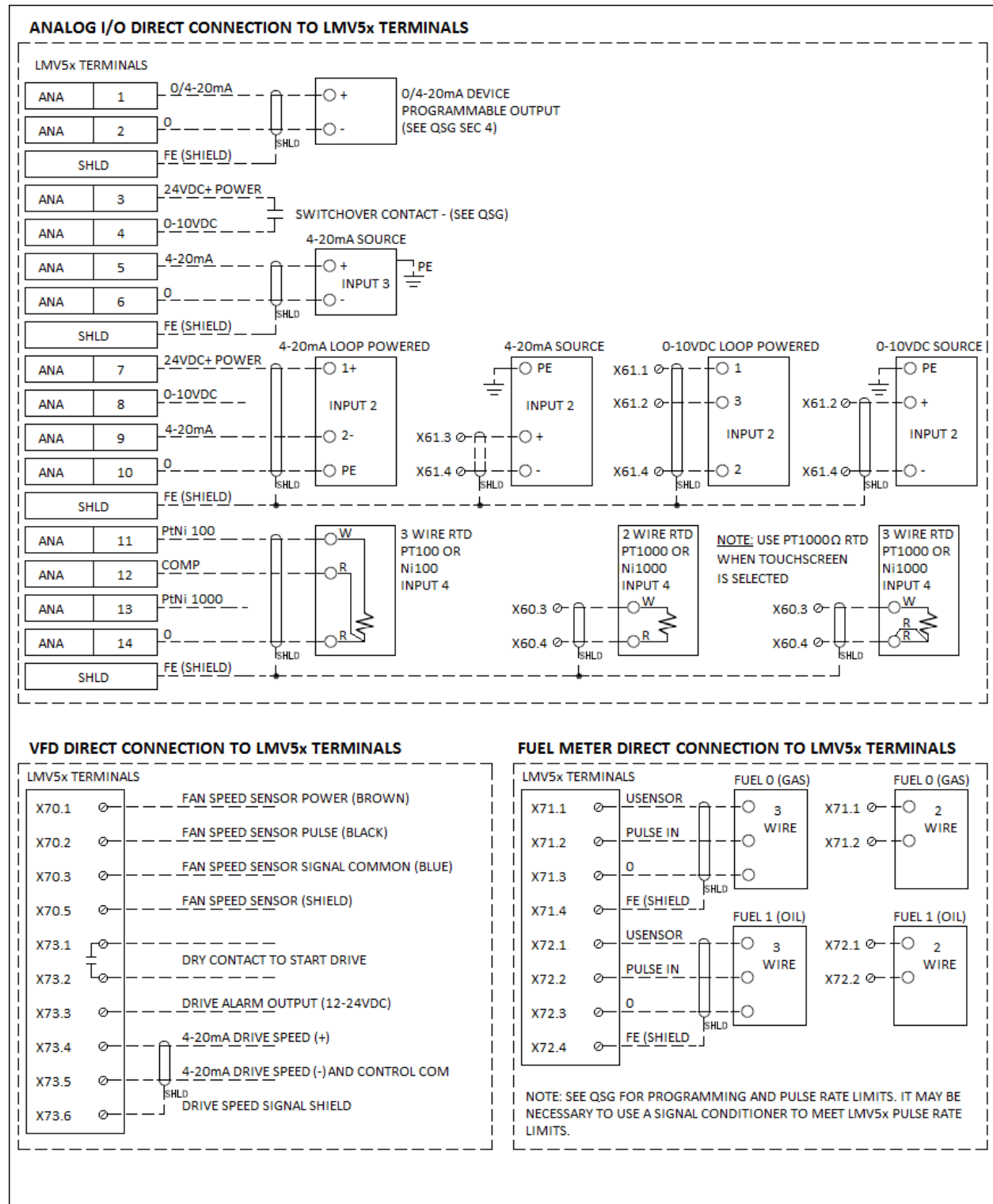

Connections (continued)

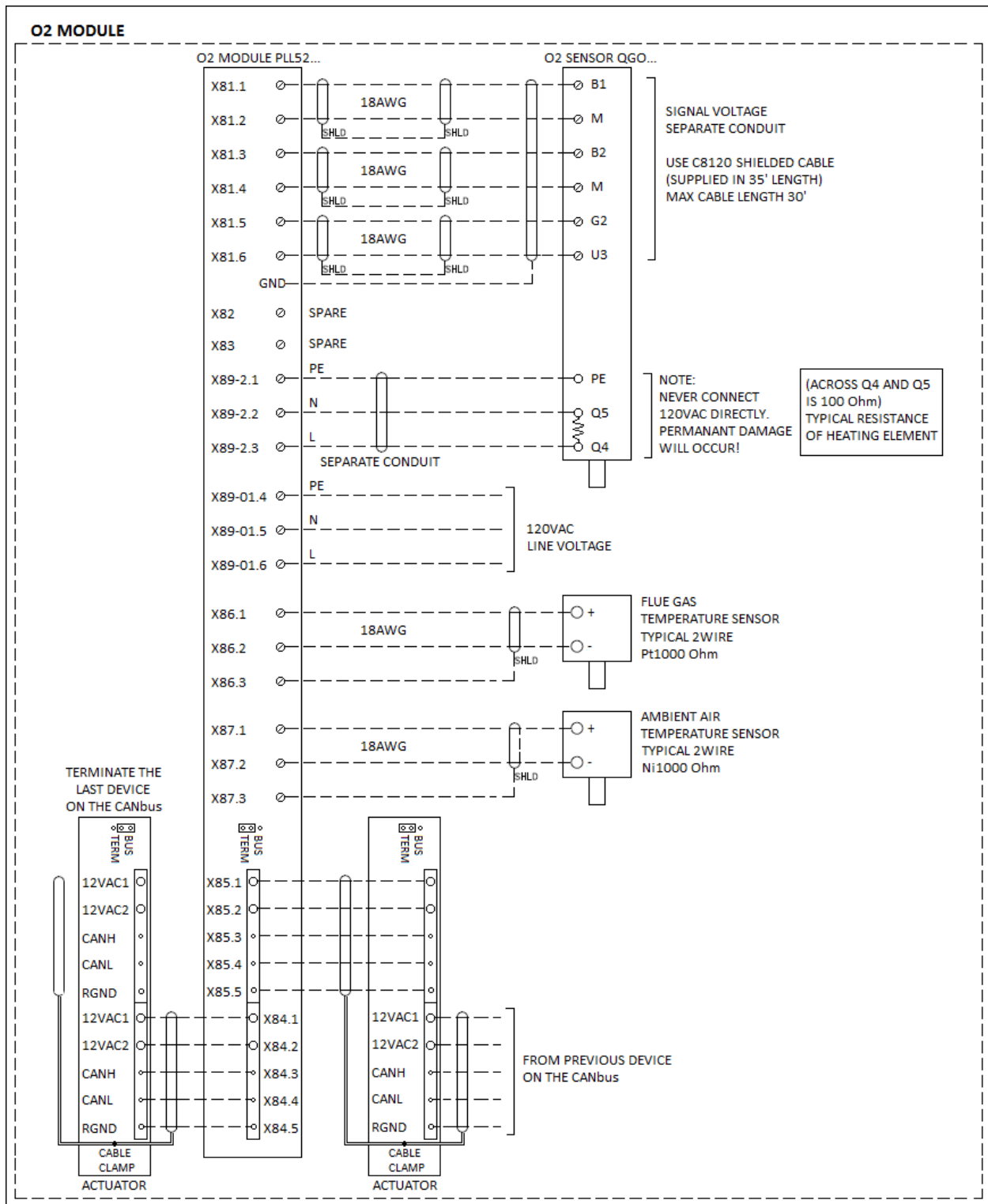

Connections (continued)

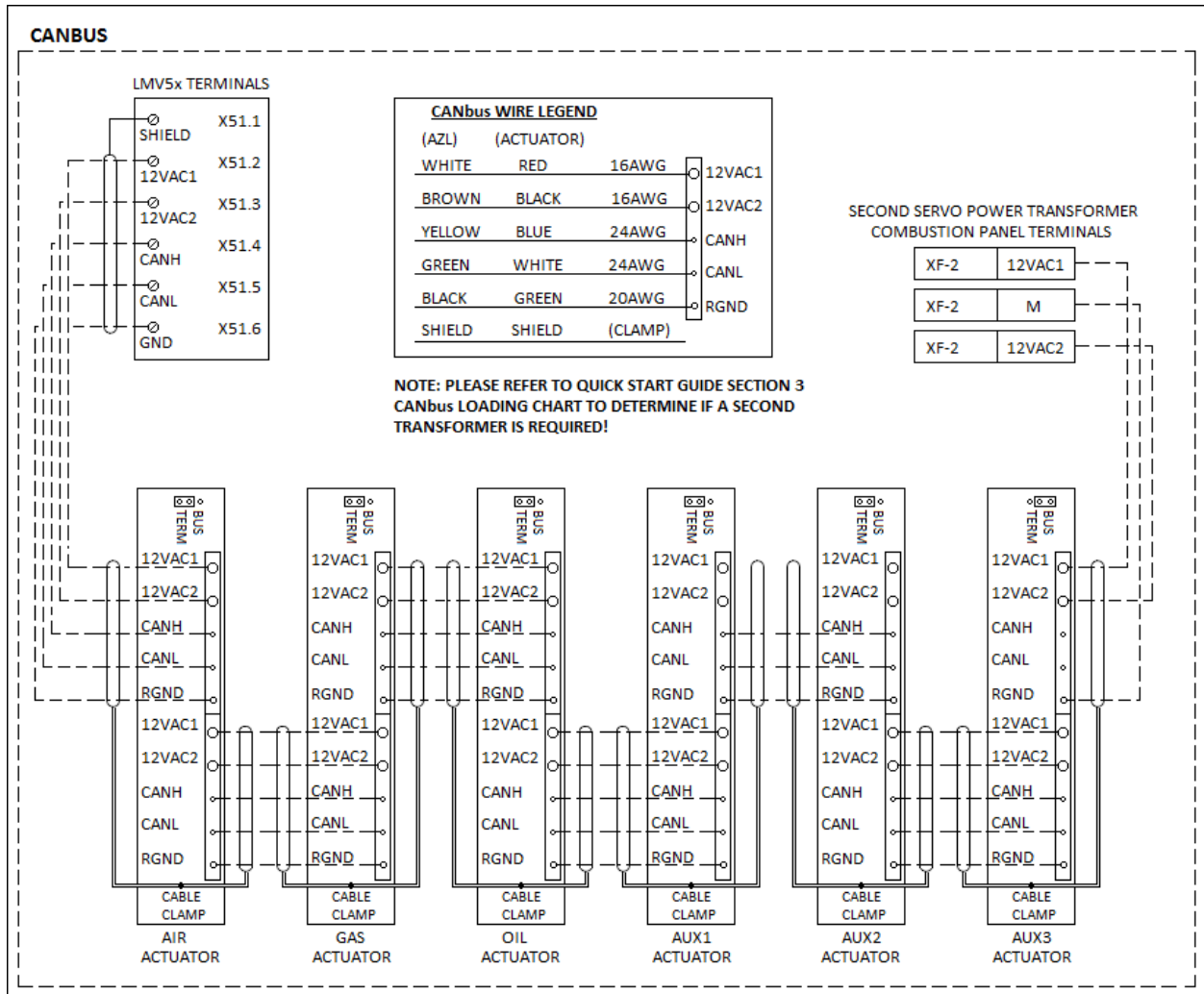

Note: Only 4 actuators may be connected on an LMV51 controller.

Connections (continued)

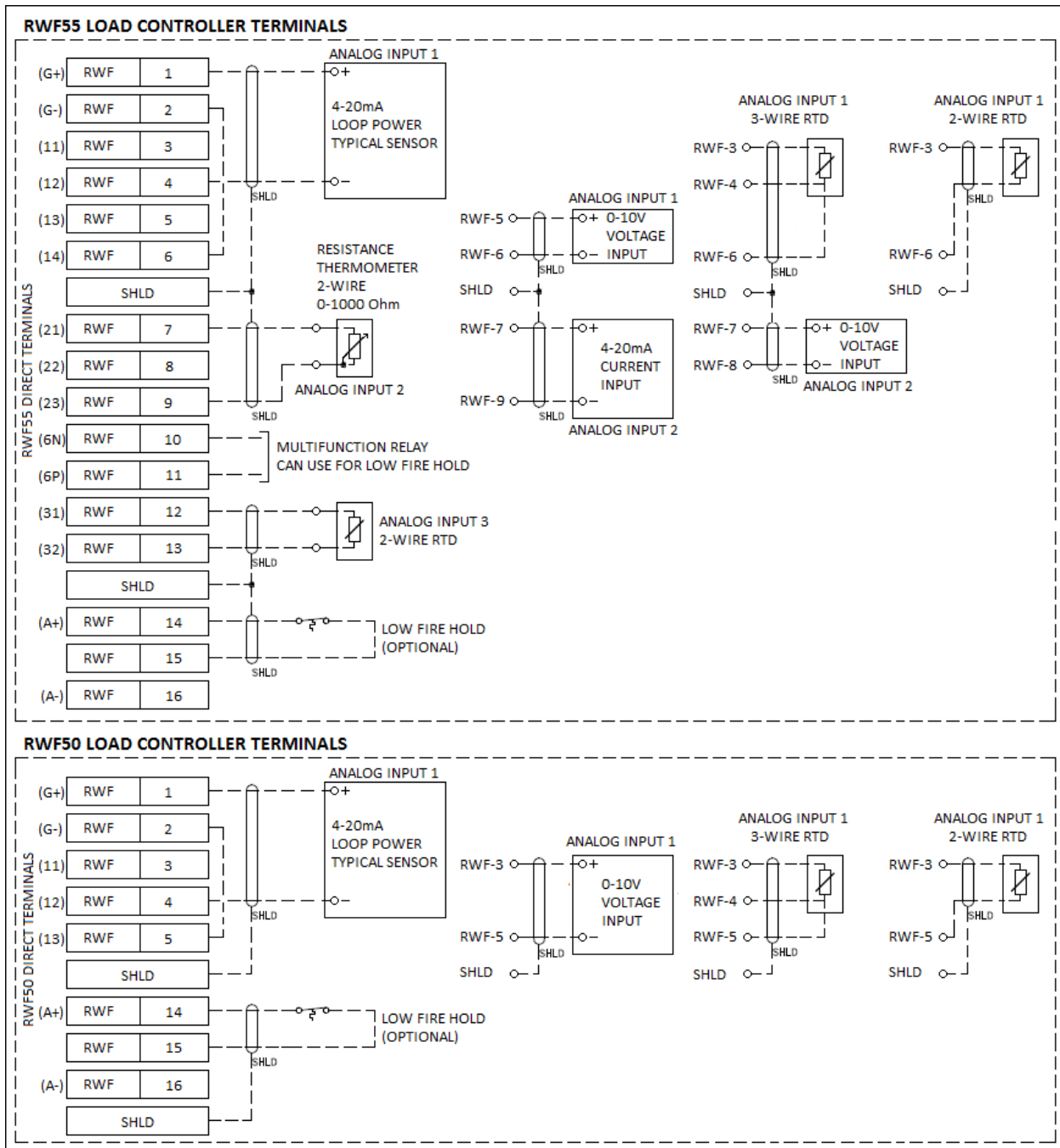

Connections (continued)

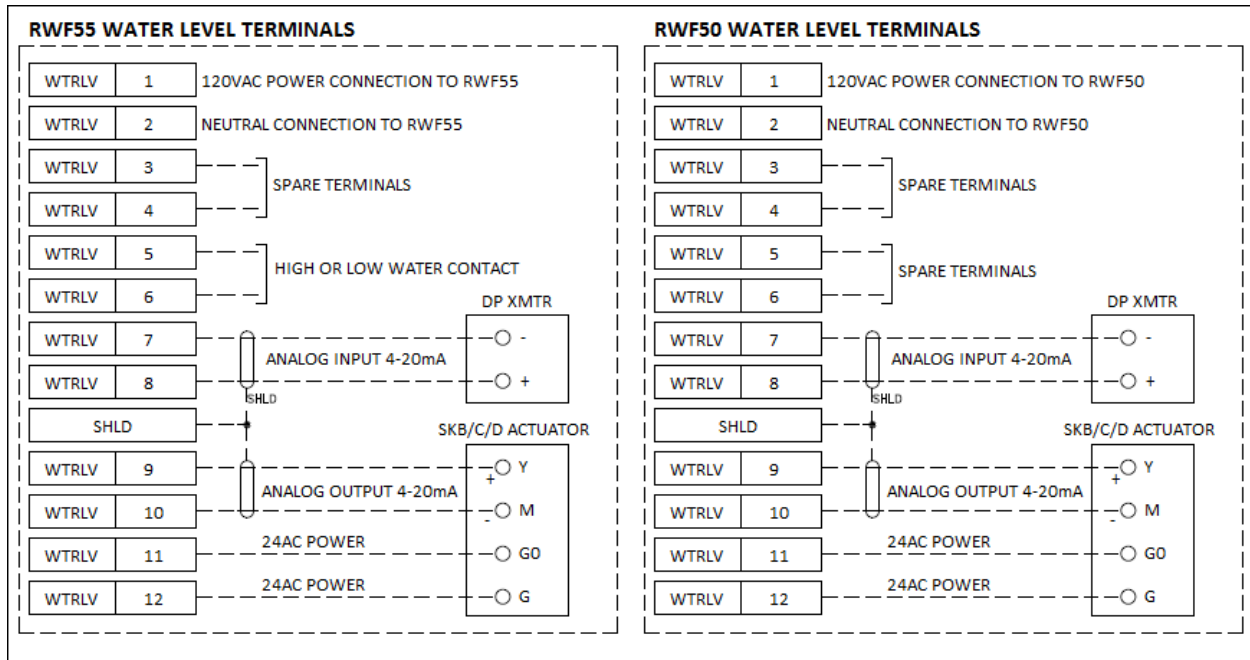

Connections (continued)

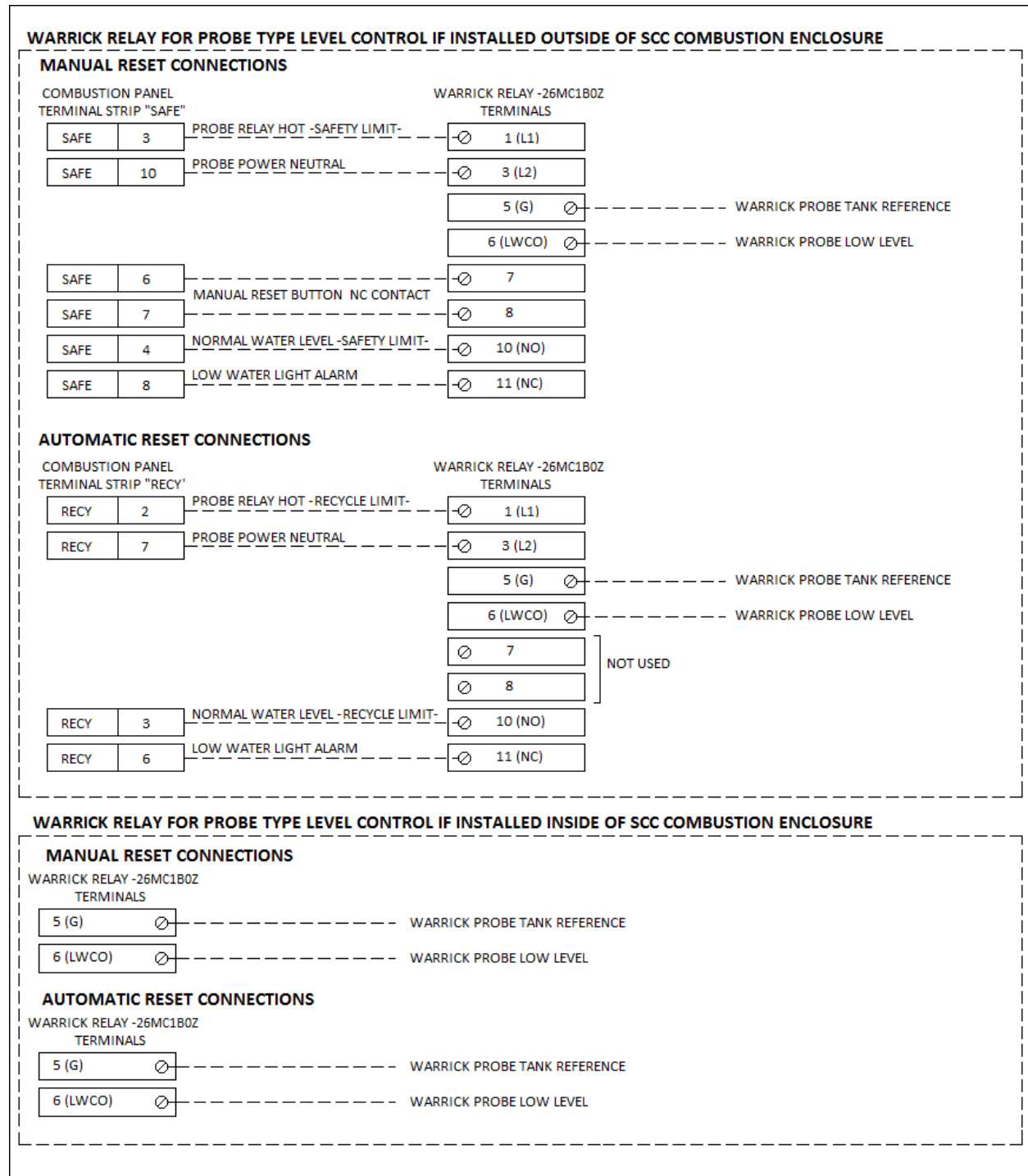

Connections (continued)

Additional RWF55 loop control Modbus connection. Only for kits with annunciation options for up to two connections:

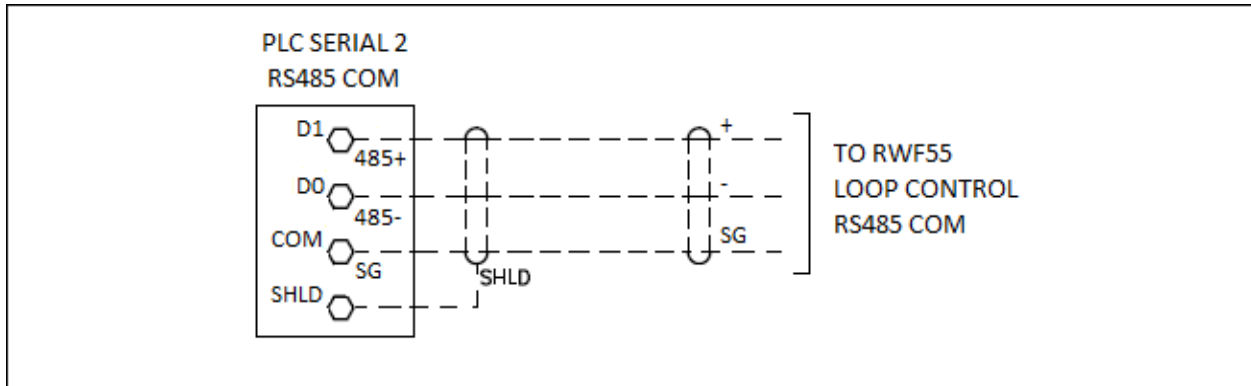

Modbus RS485 serial connection with Yaskawa drive:

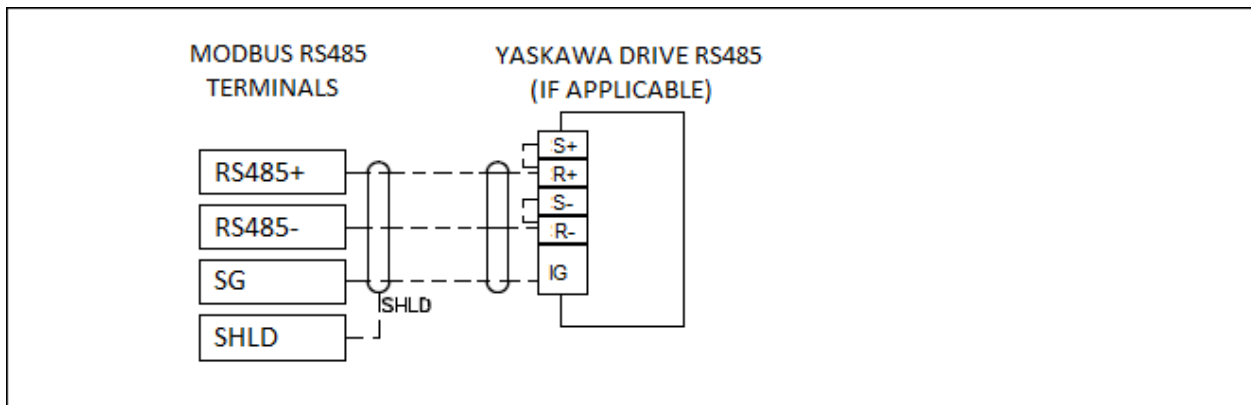

Modbus RS485 serial connection with RWF55 water level and Yaskawa drive:

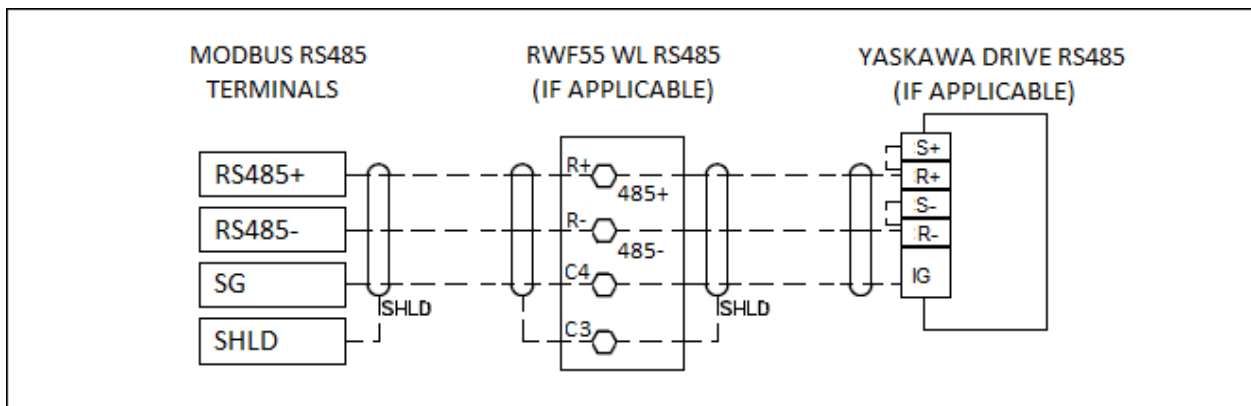

Connections (continued)

Standard annunciation thirteen (13) 120 VAC inputs:

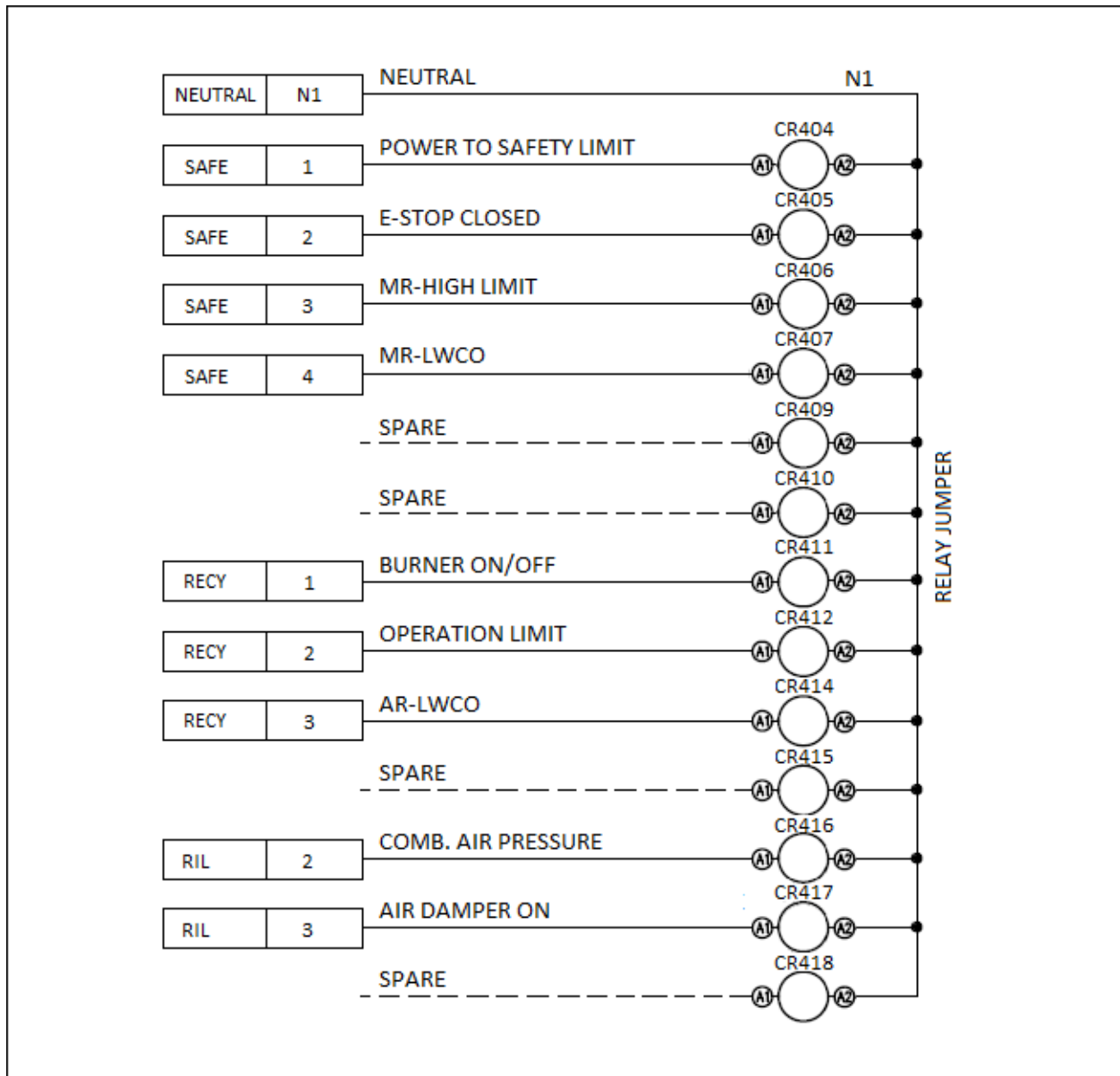

Connections (continued)

Standard annunciation thirteen (13) 120 VAC inputs (with optional draft control):

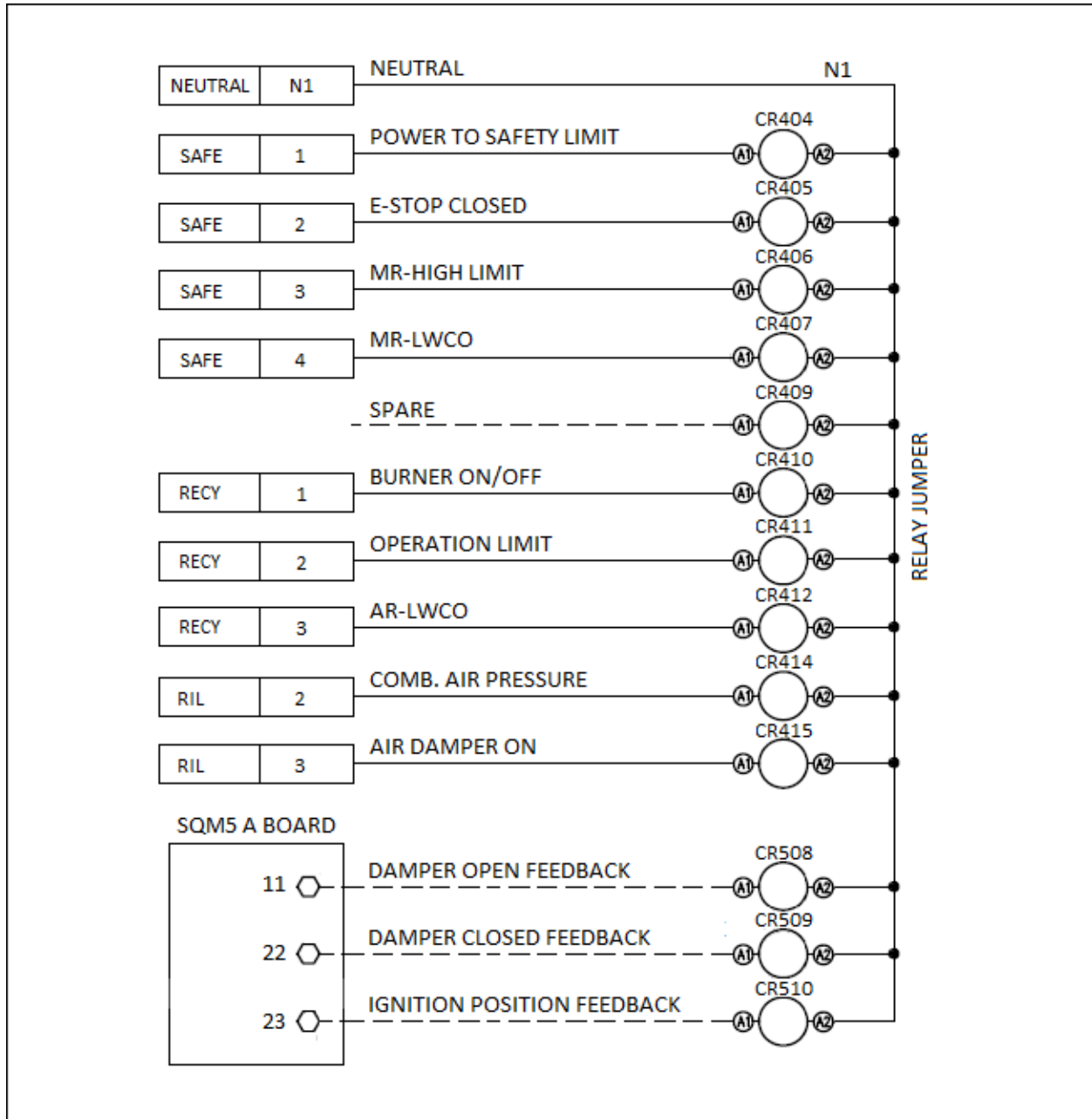

Connections (continued)

Pump proven input terminals:

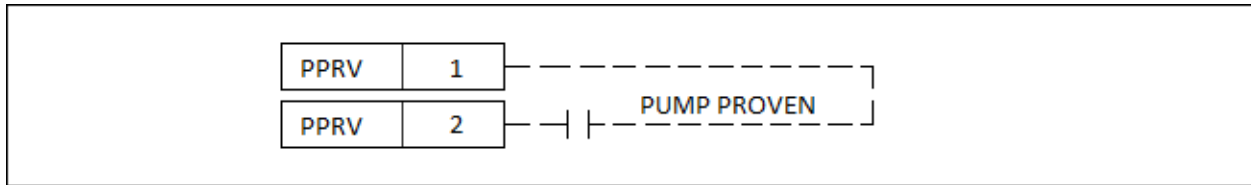

Output relay terminals:

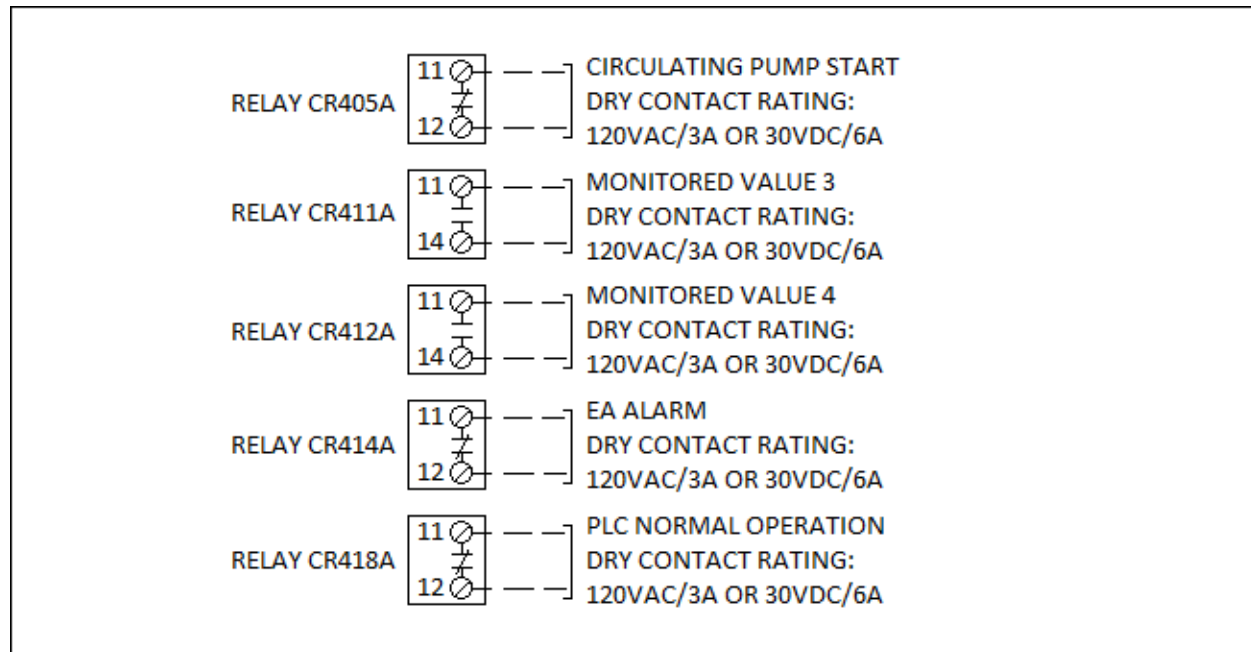

Connections (continued)

Analog input terminals:

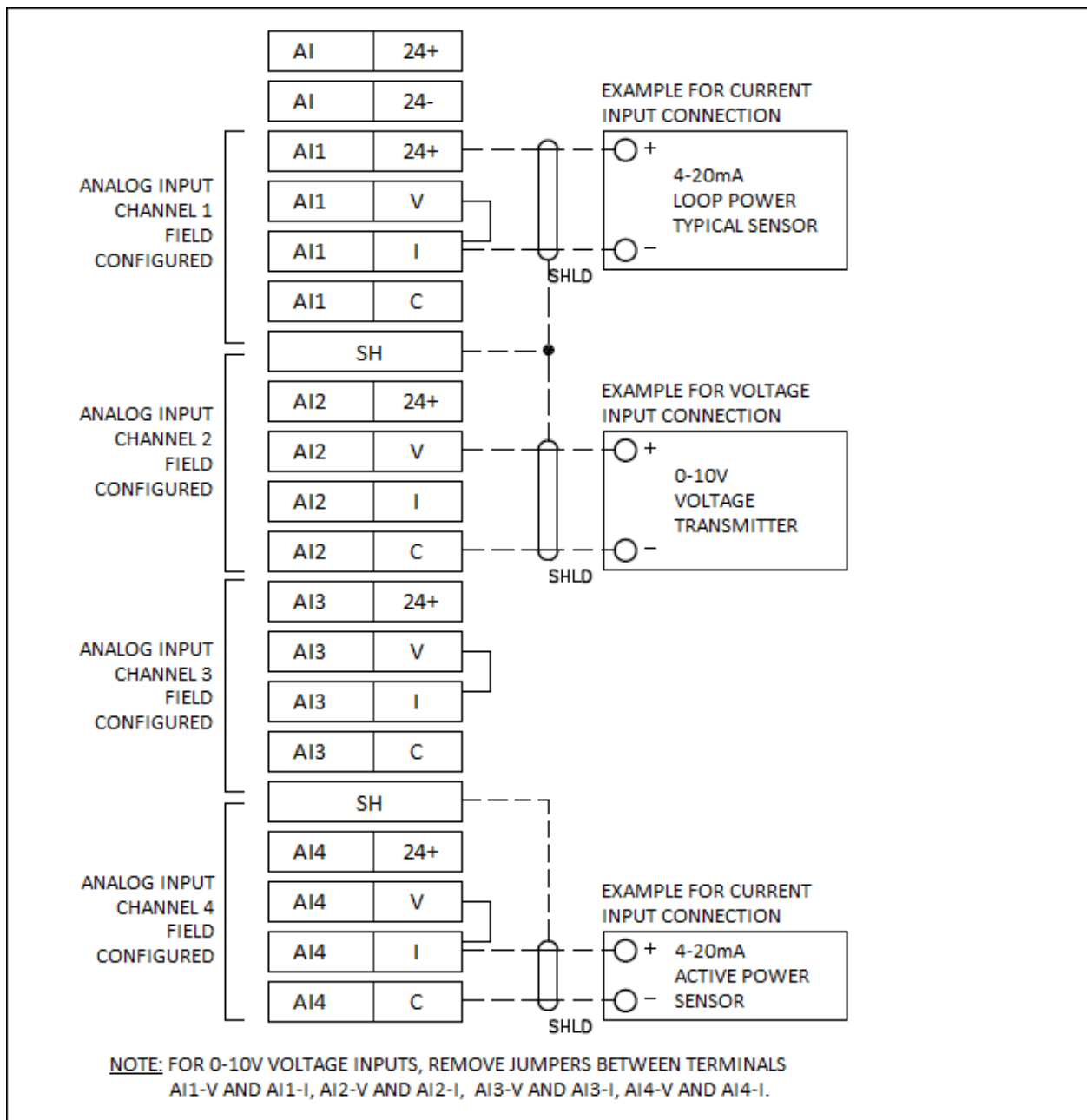

Connections (continued)

Analog output terminals:

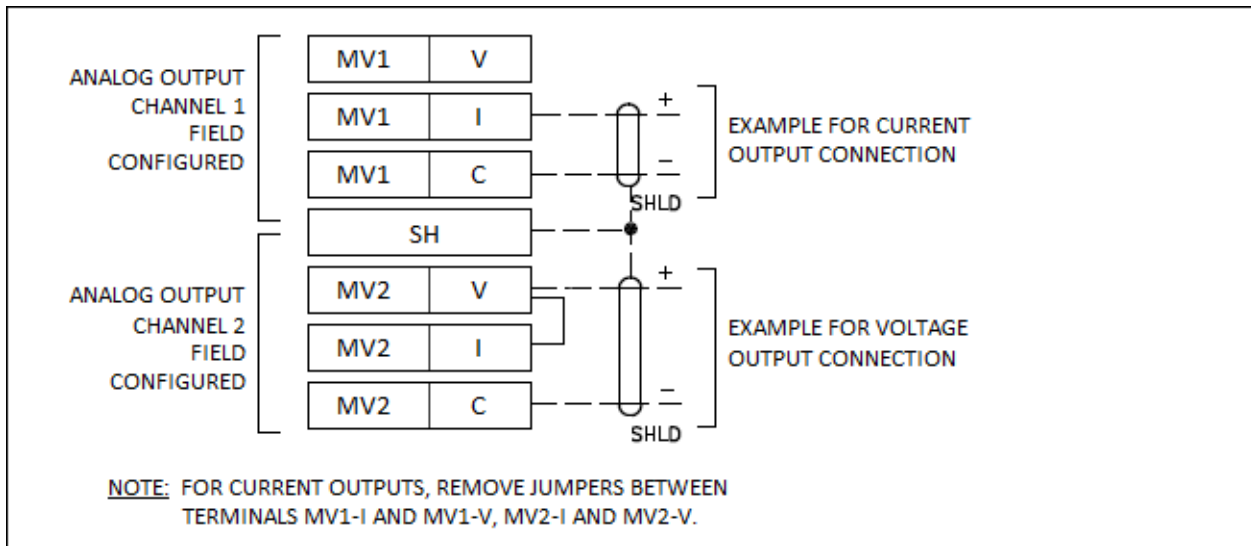

Connections (continued)

RTD Pt or LG-Ni 1000 Ohm input terminals:

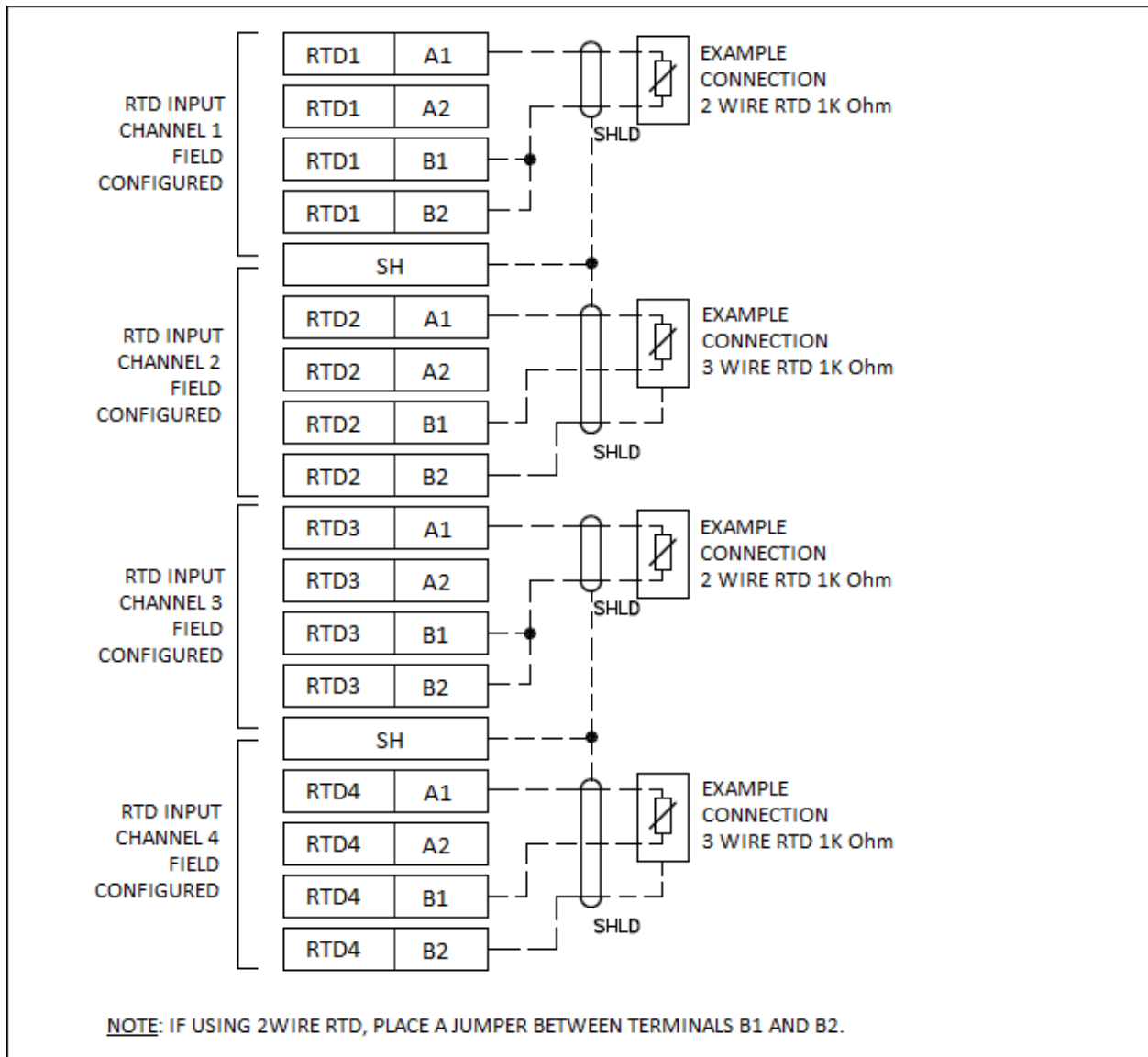

Connections (continued)

RTD Pt or LG-Ni 1000 Ohm input terminals for economizer:

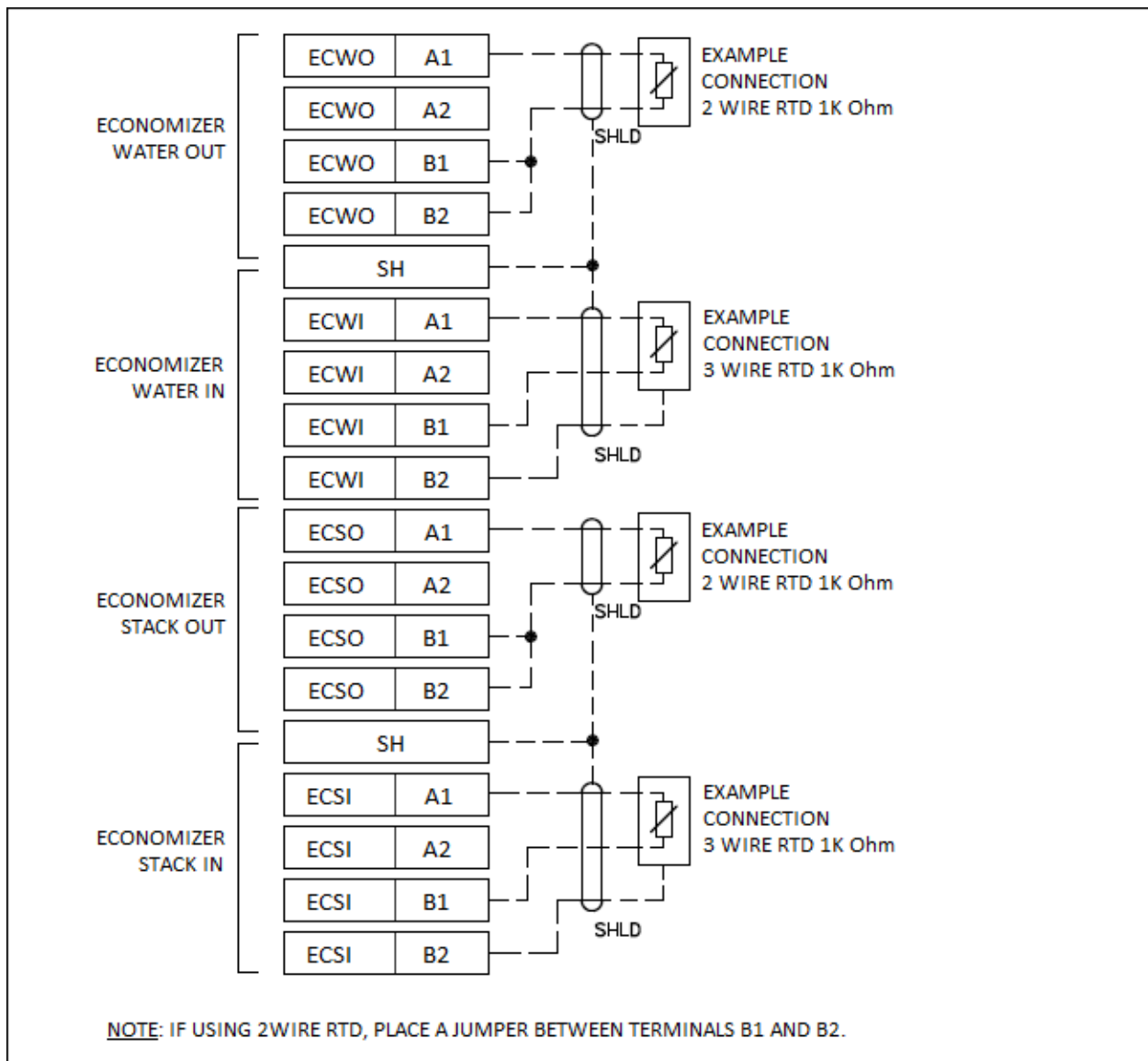

Connections (continued)

Draft Control:

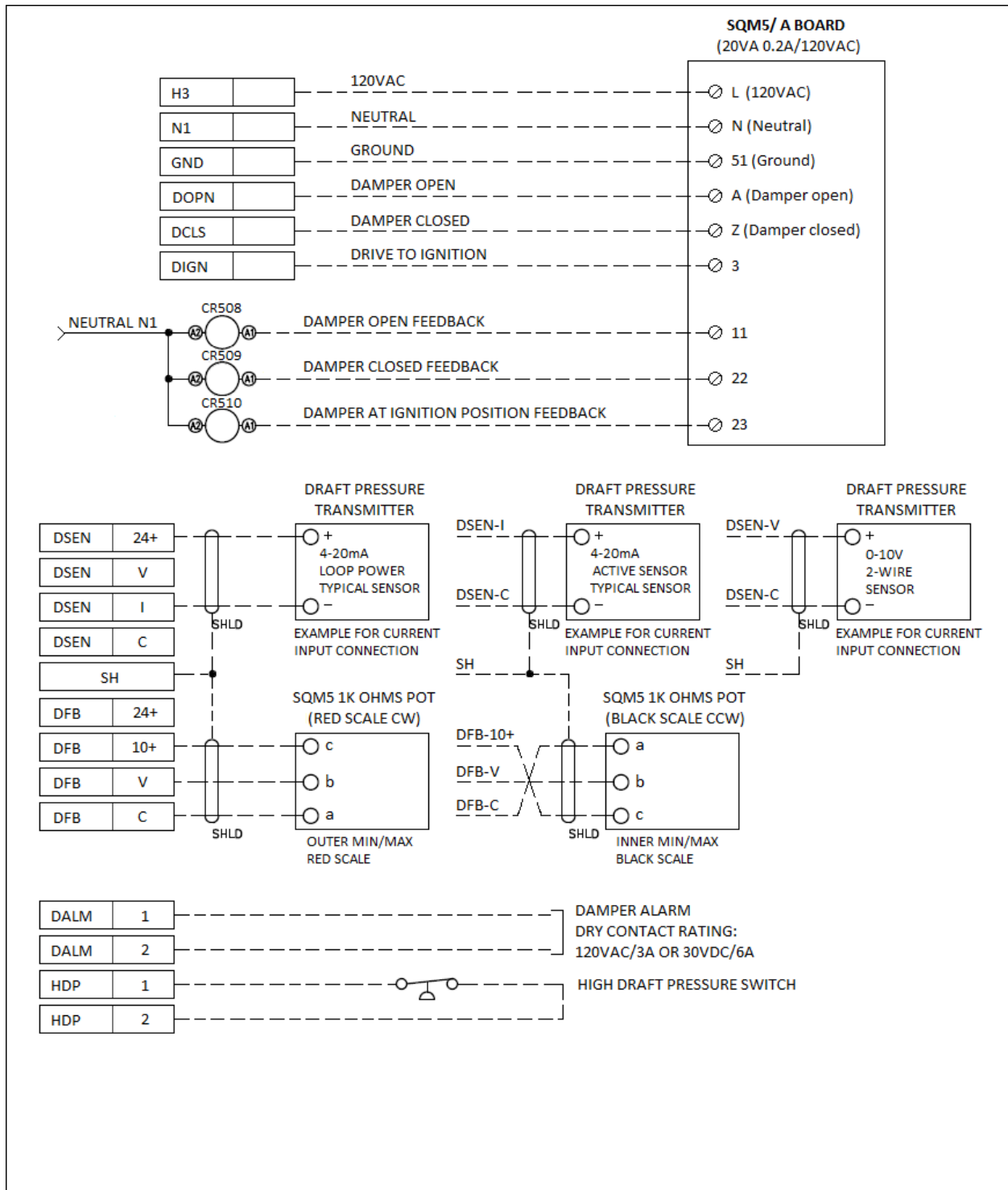

Connections (continued)

BMS Communication Connections

Standard Modbus TCP/IP:

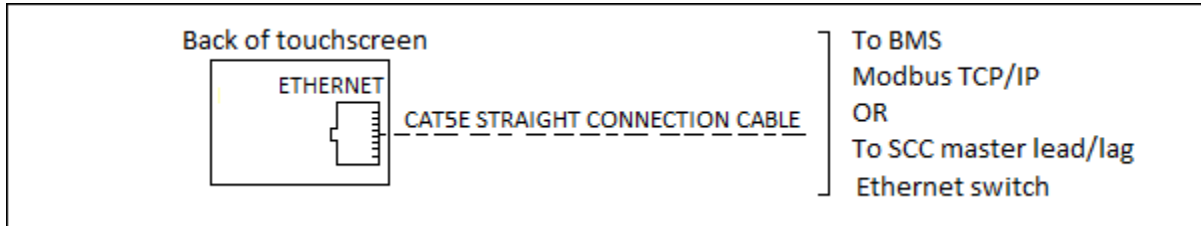

BACnet/IP, EtherNet/IP, or PROFINET (RTA):

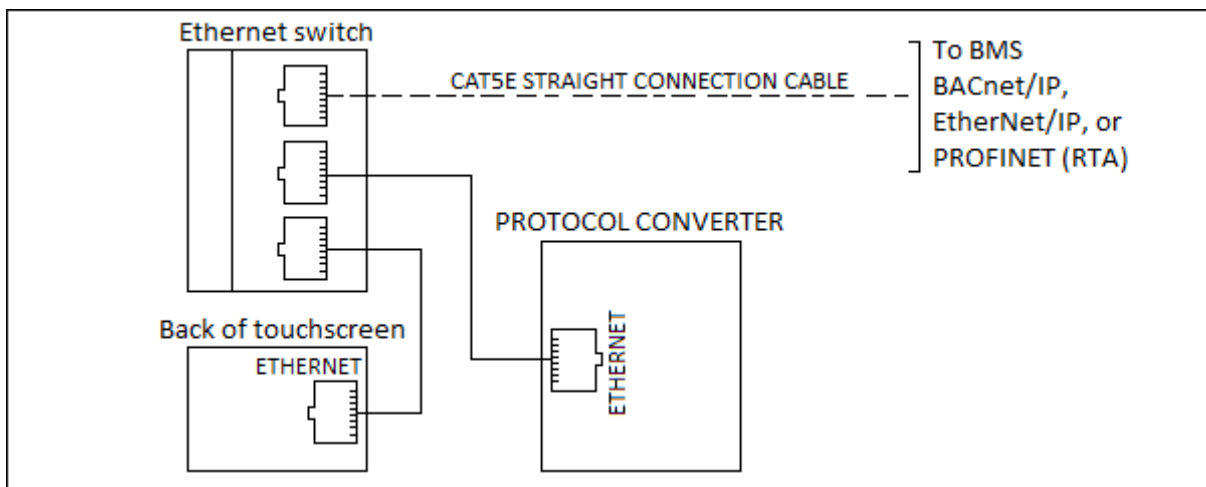

Modbus TCP/IP with PLC annunciation:

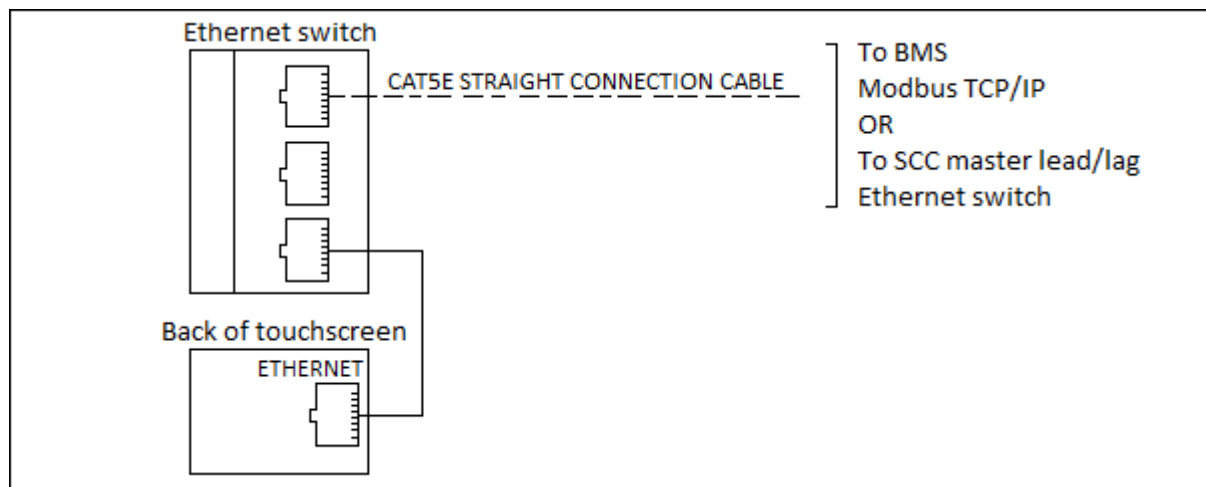

Connections (continued)

PROFIBUS:

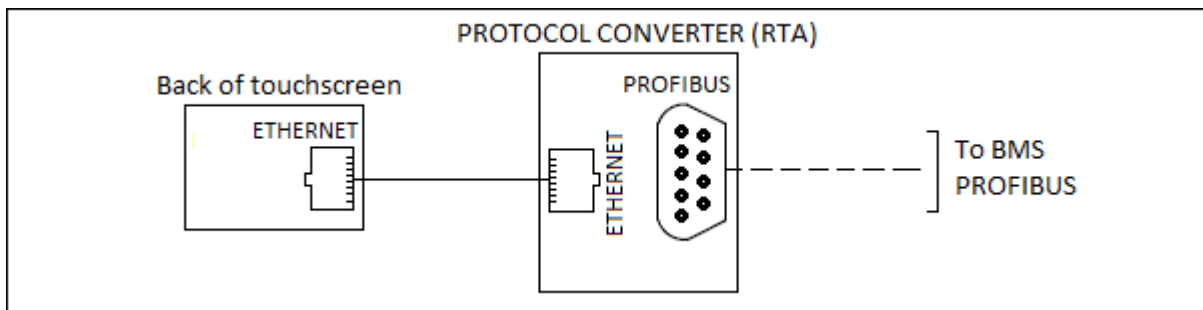

LonWorks:

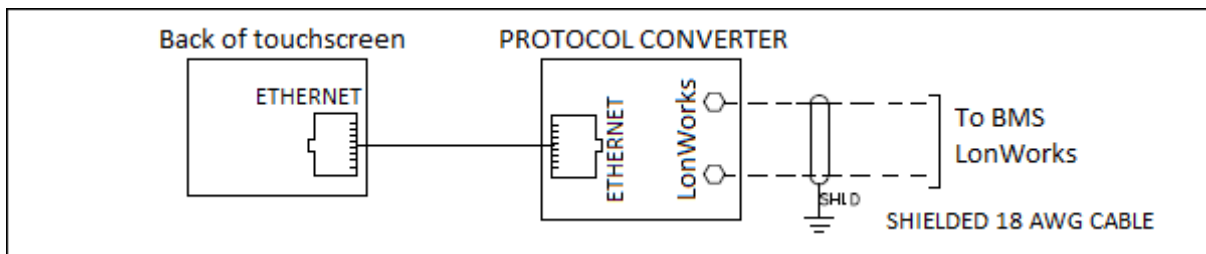

ProtoNode N2 Johnson Metasys, BACnet MS/TP or Modbus RTU:

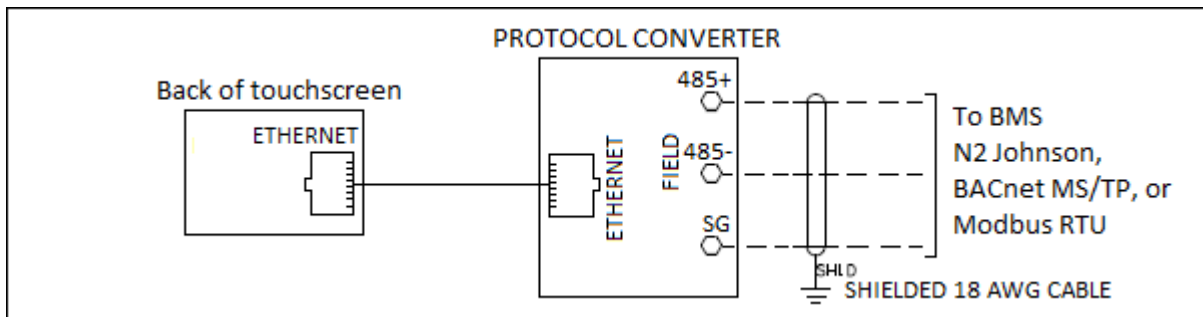

ProtoAir N2 Johnson Metasys, BACnet MS/TP or Modbus RTU:

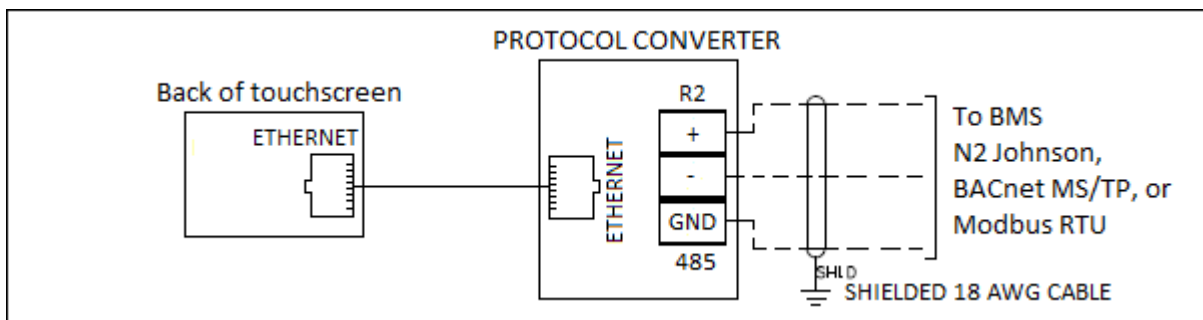

Connections (continued)

BMS serial connection RS232 without touchscreen:

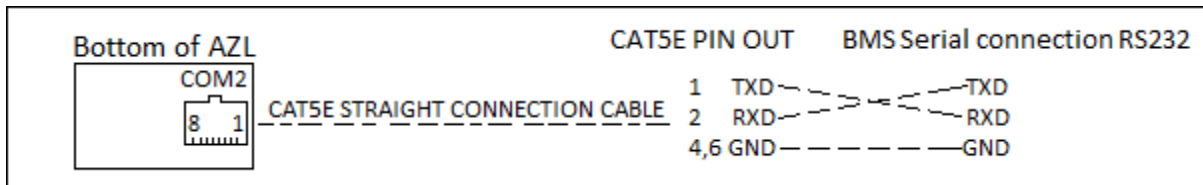

BMS serial connection RS485:

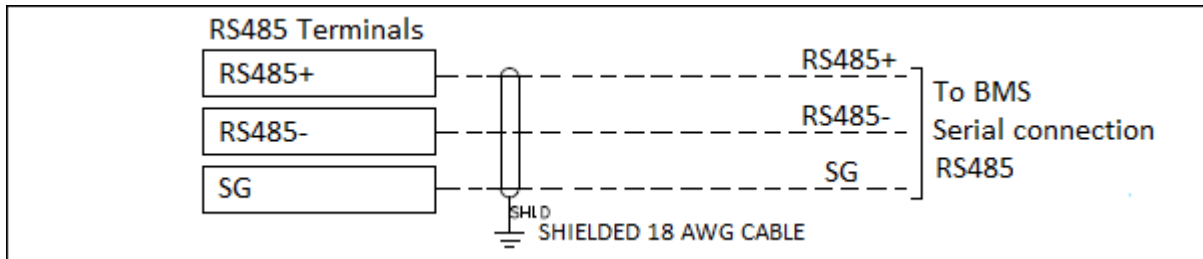

Internal Panel Parts Descriptions

24" x 24" x 10" Combustion Enclosure

TS-CEx22-xXXx-xX2-XXXX

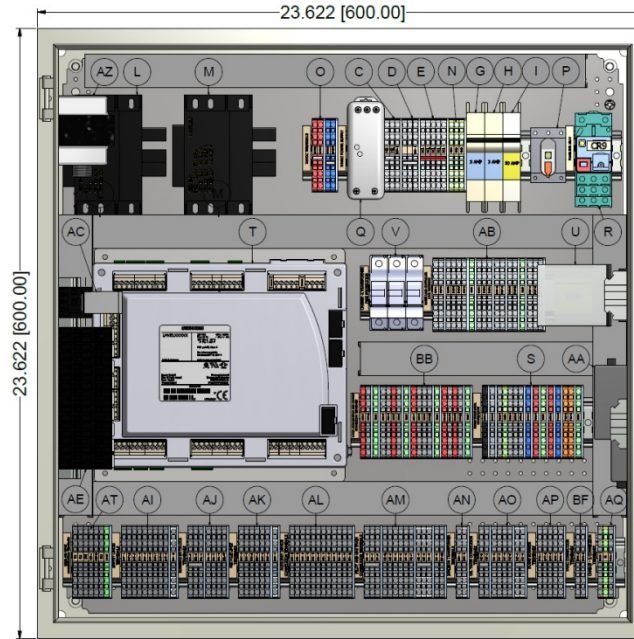

A-	N/A	AB-	RWF55 load controller field terminals , LMV51 only (optional)
B-	N/A	AC-	LMV lockout relay
C-	120 VAC H1 power distribution terminals	AD-	N/A
D-	120 VAC H2 power distribution terminals	AE-	LMV5 output relays
E-	Neutral N1 distribution terminals	AF-	N/A
F-	N/A	AG-	N/A
G-	RWF55 water level circuit protection	AH-	N/A
H-	DC power supply circuit protection	AI-	Safety limits field terminals
I-	Main power circuit protection	AJ-	Running interlocks field terminals
J-	N/A	AK-	Recycle limits field terminals
K-	N/A	AL-	Auxiliary devices output terminals
L-	AGG5.210 120 VAC to 24 VAC LMV5 transformer	AM-	Pilot and gas train field terminals
M-	AGG5.210 120 VAC to 24 VAC LMV5 transformer (optional)	AN-	Ignition transformer field terminals
N-	Ground GND distribution terminals	AO-	Oil train field terminals (optional)
O-	24 VDC +/- distribution terminals	AP-	Flame scanner field terminals
P-	Main disconnect single phase 120 VAC 16A/40A	AQ-	CANbus, 2 actuator field terminals (optional)
Q-	60W 24 VDC power supply	AR-	N/A
R-	Power fail relay	AS-	N/A
S-	RWF55 water level terminals	AT-	RS232/RS485 devices connection terminals
T-	LMV linkage control and flame safeguard controller	AU-	N/A
U-	N/A	AV-	N/A
V-	LMV second transformer fuses and fuse holders	AW-	N/A
W-	N/A	AX-	N/A
X-	N/A	AY-	N/A
Y-	N/A	AZ-	Water level SKD actuator 24 VAC transformer (optional)
Z-	N/A	BB-	LMV analog input/output terminals
AA-	BMS Interface Module (BACnet, LON, N2) (optional)	BF-	HVAC LMV start command output terminals

Internal Panel Parts Descriptions (continued)

32" x 32" x 10" Combustion Enclosure

TS-CEX22-xE8x-x22-XXXX

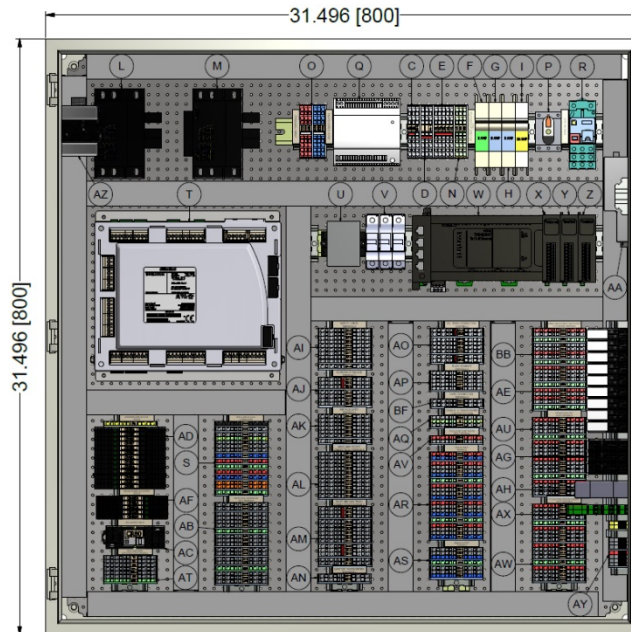

A-	N/A	AD-	Expanded annunciation 13 Relays 120 VAC
B-	N/A	AE-	LMV5 output relays
C-	120 VAC H1 power distribution terminals	AF-	Circulating pump hot water boilers only, general alarm, PLC health, and monitored digital value output relays
D-	120 VAC H2 power distribution terminals	AG-	Draft control relays (optional)
E-	Neutral N1 distribution terminals	AH-	Draft control high pressure trip time delay timer (optional)
F-	Draft control circuit protection	AI-	Safety limits field terminals
G-	RWF55 water level circuit protection	AJ-	Running interlocks field terminals
H-	DC power supply circuit protection	AK-	Recycle limits field terminals
I-	Main power circuit protection	AL-	Auxiliary devices output terminals
J-	N/A	AM-	Pilot and gas train field terminals
K-	N/A	AN-	Ignition transformer field terminals
L-	AGG5.210 120 VAC to 24 VAC LMV5 transformer	AO-	Oil train field terminals (optional)
M-	AGG5.210 120 VAC to 24 VAC LMV5 transformer (optional)	AP-	Flame scanner field terminals
N-	Ground GND distribution terminals	AQ-	CANbus, 2 actuator field terminals (optional)
O-	24 VDC +/- distribution terminals	AR-	4 analog input field terminals (optional)
P-	Main disconnect single phase 120 VAC 16A/40A	AS-	2 analog output field terminals (optional)
Q-	Up to 90W 24 VDC power supply	AT-	RS232/RS485 devices connection terminals
R-	Power fail relay	AU-	4 RTD input field terminals (optional)
S-	RWF55 water level terminals	AV-	Circulating pump proven field terminals
T-	LMV linkage control and flame safeguard controller	AW-	4 RTD input for economizer field terminals (optional)
U-	Manual reset LWCO Warrick relay (optional)	AX-	Draft damper open/close output relays and draft damper alarm dry contact (optional)
V-	LMV second transformer fuses and fuse holders	AY-	Draft control to LMV permissive and shutdowns terminals (optional)
W-	Programmable logic controller (PLC) (optional)	AZ-	Water level SKD actuator 24 VAC transformer (optional)
X-	4 input analog input module (optional)	BB-	LMV analog input/output terminals
Y-	4 input RTD input module (optional)	BF-	HVAC LMV start command output terminals
Z-	4 input RTD Input Module (optional)		
AA-	BMS interface module (BACnet, LON, N2) (optional)		
AB-	RWF55 load controller field terminals, LMV51 only (optional)		
AC-	LMV lockout relay		

Internal Panel Parts Descriptions (continued)**42" x 32" x 10" Combustion Enclosure**

TS-CEx2x-xE8x-x22-xxx

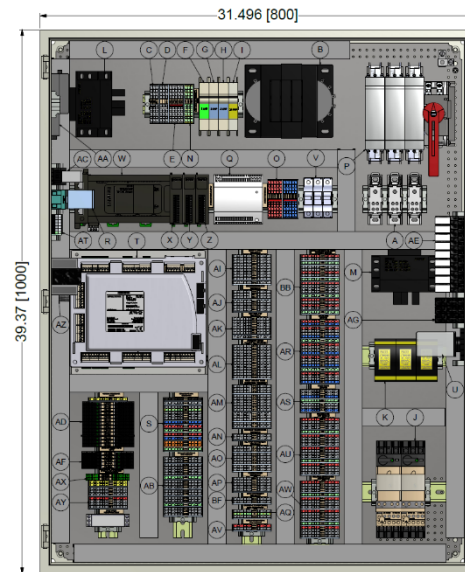
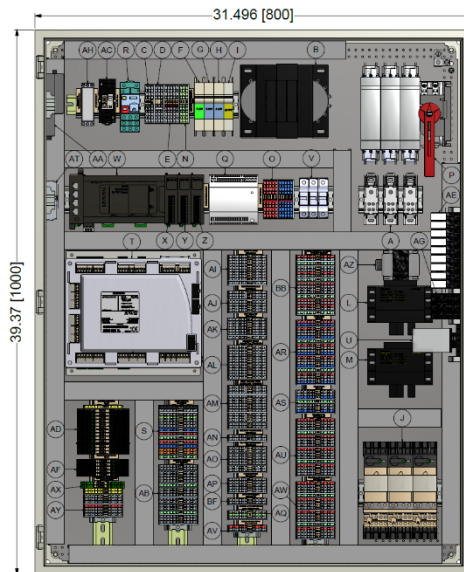

- A- Power distribution 3 phase blocks
- B- 750/1000 VA control transformer (480-120 VAC)
- C- 120 VAC H1 power distribution terminals
- D- 120 VAC H2 power distribution terminals
- E- Neutral N1 distribution terminals
- F- Draft control circuit protection
- G- RWF55 water level circuit protection
- H- DC power supply circuit protection
- I- Main power circuit protection
- J- Motor starters for the blower for up to 20hp , oil pump for up to 10hp, and compressor motor for up to 20hp
- K- VSD fuses and fuse holder for up to 20hp blower motor
- L- AGG5.210 120 VAC to 24 VAC LMV5 transformer
- M- AGG5.210 120 VAC to 24 VAC LMV5 transformer
- N- Ground GND distribution terminals
- O- 24 VDC +/- distribution terminals
- P- Main three phase 480VAC fused disconnect 30A or 60A
- Q- Up to 90W 24 VDC power supply
- R- Power fail relay
- S- RWF55 water level terminals
- T- LMV linkage control and flame safeguard controller
- U- Manual reset LWCO Warrick relay (optional)
- V- LMV second transformer fuses and fuse holders
- W- Programmable logic controller (PLC) (optional)
- X- 4 inputs analog input module (optional)
- Y- 4 inputs RTD input module (optional)
- Z- 4 inputs RTD input module (optional)
- AA- BMS interface module (BACnet, LON, N2) (optional)

- AB- RWF55 load controller field terminals, LMV51 only
- AC- LMV lockout relay
- AD- Expanded annunciation 13 Relays 120 VAC
- AE- LMV5 output relays
- AF- Circulating pump hot water boilers only, general alarm, PLC health, and monitored digital value output relays
- AG- Draft control relays (optional)
- AH- Draft control high pressure trip time delay timer (optional)
- AI- Safety limits field terminals
- AJ- Running interlocks field terminals
- AK- Recycle limits field terminals
- AL- Auxiliary devices output terminals
- AM- Pilot and gas train field terminals
- AN- Ignition transformer field terminals
- AO- Oil train field terminals (optional)
- AP- Flame scanner field terminals
- AQ- CANbus, 2 actuator field terminals (optional)
- AR- 4 analog input field terminals (optional)
- AS- 2 analog output field terminals (optional)
- AT- RS232/RS485 devices connection terminals
- AU- 4 RTD input field terminals (optional)
- AV- Circulating pump proven field terminals
- AW- 4 RTD inputs for economizer field terminals (optional)
- AX- Draft damper open/close output relays and draft damper alarm dry contact (optional)
- AY- Draft control to LMV permissive and shutdowns terminals (optional)
- AZ- Water level SKD actuator 24 VAC transformer (optional)
- BB- LMV analog input/output terminals
- BF- HVAC LMV start command output terminals

Dimensions

Dimensions in inches; millimeters in brackets

24" x 24" x 10" Combustion Enclosure

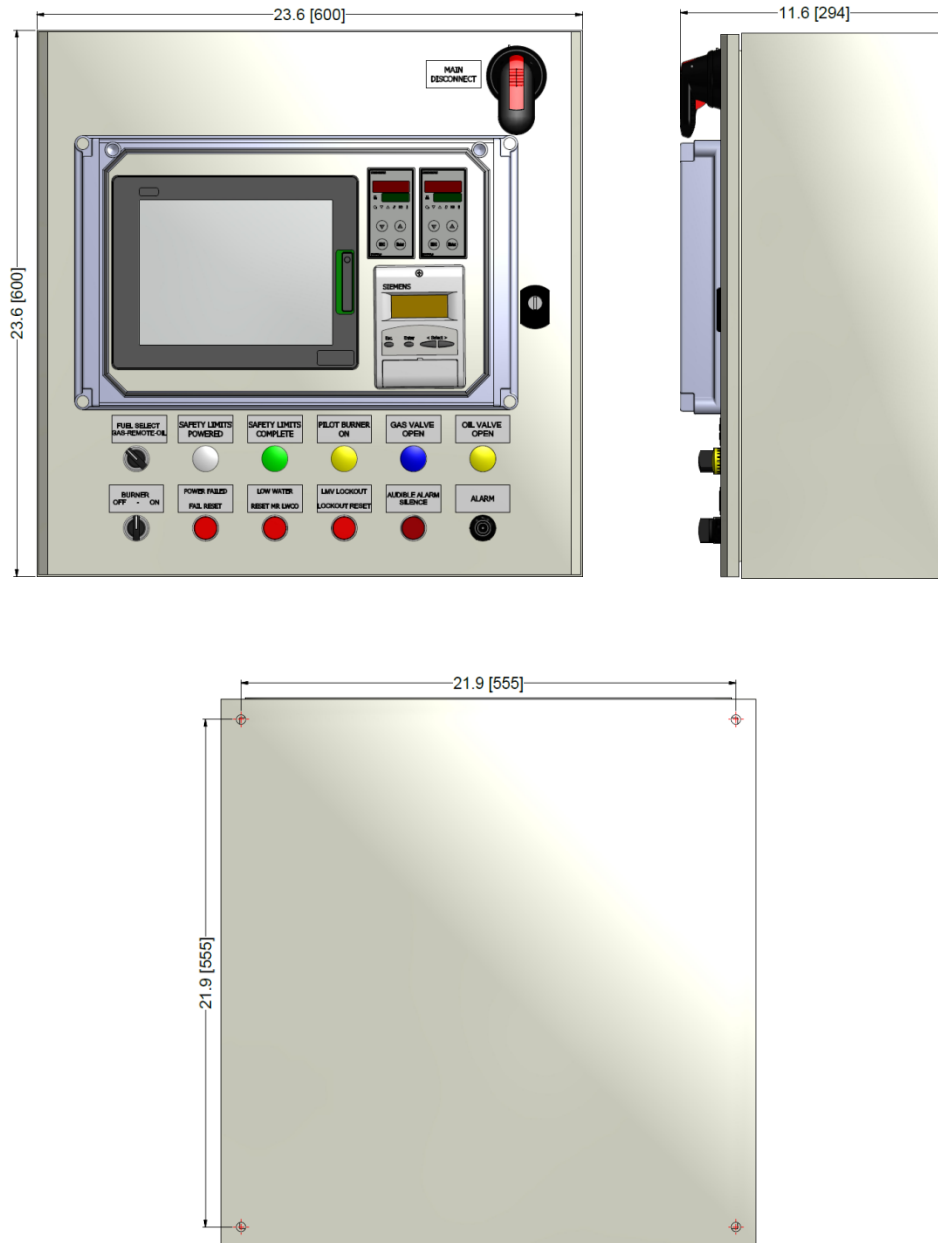

Dimensions (continued)

Dimensions in inches; millimeters in brackets

32" x 32" x 10" Combustion Enclosure

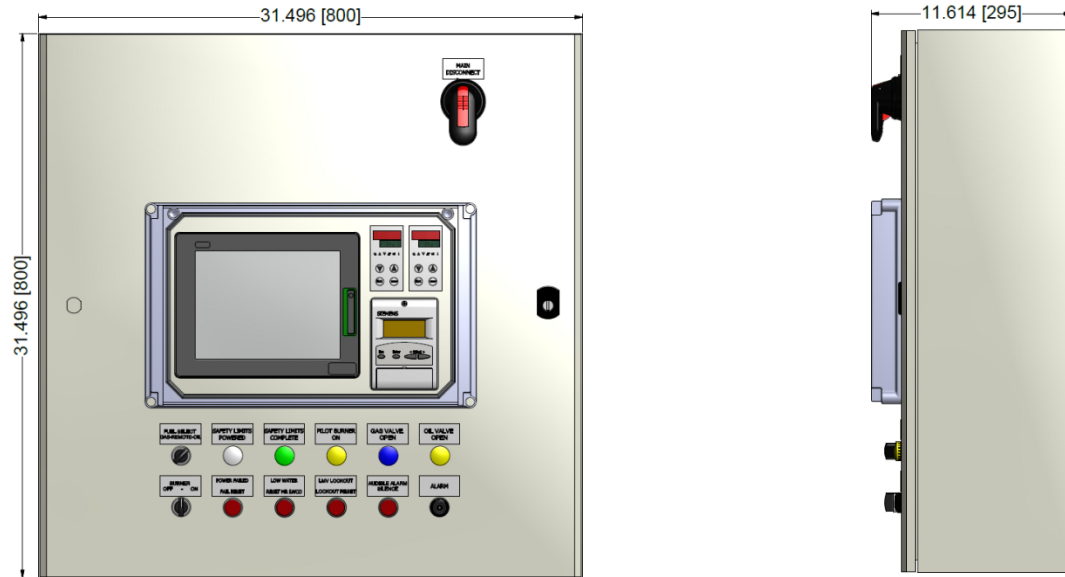

Dimensions (continued)

Dimensions in inches; millimeters in brackets

40" x 32" x 10" Combustion Enclosure

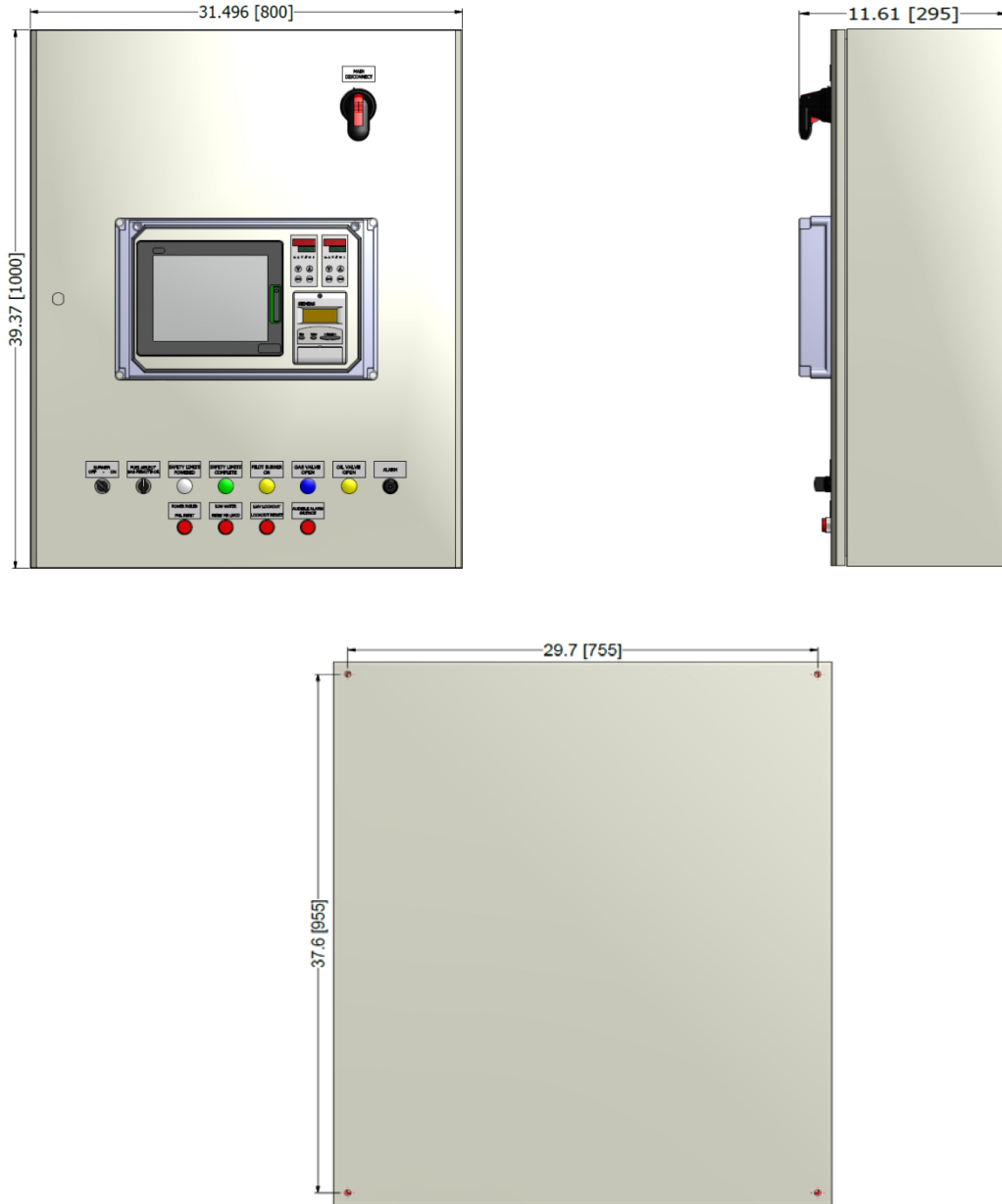

Information in this publication is based on current specifications. The company reserves the right to make changes in specifications and models as design improvements are introduced. Product or company names mentioned herein may be the trademarks of their respective owners. © 2009 SCC Inc.