

VGD Series

VGDxx.xxxU Gas Valves

for use with SKPxx.xxxU electro-hydraulic actuators



VGD20.xxxU



VGD40.xxxU

ISO 9001 and 14000
REGISTERED FIRM



Only with series SKPxx.xxxUx actuators

Description

The normally closed VGDxx.xxxU series of modular double-body gas valves combine with SKPxx.xxxU series electro-hydraulic actuators to provide safety shut-off, gas pressure regulation and/or air-gas ratio control for commercial or industrial gas burners.

Table 1. VGDxx.xxxU model numbers

Model Numbers	Body style	Connection
VGD20.253U	Double	NPT thread
VGD20.323U	Double	NPT thread
VGD20.403U	Double	NPT thread
VGD20.503U	Double	NPT thread
VGD40.065U	Double	NPT thread
VGD40.080U	Double	NPT thread
VGD40.100U	Double	ANSI flange
VGD40.150U	Double	ANSI flange

Features**All Models**

- UL listed, FM approved, CSA certified, IRI approvable, ISO 9001 and 14000 certified. CE, Australian approved versions available
- ¼"-inch NPT pressure taps on the inlet and outlet and between main valves (see *Table 2* for details)
- Stainless steel mesh inlet filter protects the valve seat(s) as well as downstream components
- Dual stem guides ensure precise disc alignment and tight shut-off
- Valves in connection with SKPxx.xxxU actuators open slowly and close rapidly

VGD20.xxxU models

- Compact VGD20.xxxU double-valve bodies consist of 2 safety shut-off valves in series. The first (inlet) valve has a flat valve disc applicable for safety shut-off function only. The second (outlet) valve has a contoured valve disc for use with pressure regulating actuators (SKP2x.xxxU, SKP5x.xxxU, SKP7x.xxxU)
- A 1-inch NPT vent connection between the valves
- Each VGD20.xxxU double-valve requires 2 threaded mounting flanges (AGFxx.xxU). Each flange includes the necessary installation hardware (bolts, nuts and O-ring). Each mounting flange has a ¼-inch NPT pressure tap. The flanges can be pre-mounted onto the pipe, and then bolted onto the VGD20.xxxU gas valve body. This feature eliminates the use of pipe unions and permits the gas valve assembly to be easily removed from a gas train
- Connecting pattern of the 1...2 inch AGFxx.xxU flanges are identical. This space permits any AGFxx.xxU flange to be mounted to any VGD20.xxxU valve body

**NOTE:**

VGD20.xxxU valves and AGFxx.xxU flanges must be ordered as separate items (see *Tables 2 and 3*).

VGD40.xxxU models

- Compact VGD40.xxxU double-valve bodies consist of 2 safety shut-off valves in series
- Each individual safety shut-off valve has double seats to achieve high flow
- Patented seat construction with individual closing spring for each seat to assure reliable shut-off and high close-off pressure rating
- Full port vent line connection plates are available

**NOTE:**

VGD40.xxxU valves and AGA40.xxxxU vent connection plates must be ordered as separate items (see *Tables 2 and 3*).

Application

All VGDxx.xxxU valves can be combined with any SKPxx.xxxU series actuator. The actuator can be mounted while the valve is installed and under pressure.

SKPxx.xxxU regulating actuators are applicable for both low and high supply gas pressure applications, eliminating excessive regulator inventories. Maximum pressure ratings vary with valve size (see *Table 2*).

All VGDxx.xxxU valves perform these functions in combination with each of the following actuators:

SKP15.xxxU	Safety shut-off
SKP25.xxxU	Safety shut-off and constant pressure regulation or zero governor
SKP55.xxxU	Safety shut-off, pressure regulation and differential pressure air-gas ratio control
SKP75.xxxU	Safety shut-off, pressure regulation and adjustable air/gas ratio control

Since more than one function can be performed by a single valve, fewer components and fittings are required-significantly reducing both the size and weight of the gas train. In addition, smaller diameter gas valves can be used. For details on valve sizing see the flow chart (figure 3).

**CAUTION:**

Do not oversize valves equipped with a regulating SKP2x.xxxU / SKP5x.xxxU / SKP7x.xxxU actuator. Oversizing may limit turndown and could cause oscillations.

Ordering information

Gas valves and actuators are ordered separately. For additional SKPxx.xxxU actuator information, see the following technical instructions:

SKP15.xxxU	155-751P25
SKP25.xxxU	155-752P25
SKP55.xxxU	155-753P25
SKP75.xxxU	155-754P25



NOTE:

The SKPxx.xxxU actuators have an operating temperature range of 14 °F to 140 °F (-10 °C to 60 °C)!

Table 2. Product numbers

Product number	Size	Maximum operating pressure psi	Close-off pressure psi	Capacity CFH Natural gas at $\Delta P = 1''$ W.C.	Number of test points, 1/4" NPT		Valve body material
					Inlet	Outlet	
VGD20.253U *)	1"	20	30	600	Two ¼-inch and one 1-inch port between valves		Aluminum
VGD20.323U *)	1¼"	20	30	1200			Aluminum
VGD20.403U *)	1½"	20	30	1,850			Aluminum
VGD20.503U *)	2"	20	30	2,300			Aluminum
VGD40.065U	2½" NPT	10	75	3,880	1	1	Aluminum
VGD40.080U	3" NPT	10	75	5,370	1	1	Aluminum
VGD40.100U **	4" flanged	10	30	9,680	1	1	Aluminum
VGD40.150U **	6" flanged	10	30	17,490	1	1	Aluminum

*) VGD20.xxxU double valves require 2 AGFxx.xxU threaded flanges for installation

***) VGD40.1x0U flanged valves must be installed using non-metallic flange gaskets. Gasket material must be chemically compatible with the fuel gas being used in the application and must be softer than the aluminum flange sealing surface. Acceptable gasket materials include but are not limited to: rubber, paper, and plastic. Observe flange bolt torque specifications as stated in the VGD40 installation instructions. Also refer to ANSI / ASME B16.24.

Accessories

Table 3. Accessories

Part Number	Description	Notes
AGF10.25U	Single 1" connecting flange with ¼" port for VGD20.xxxU	2 required per valve. Order separately
AGF10.32U	Single 1¼" connecting flange with ¼" port for VGD20.xxxU	
AGF10.40U	Single 1½" connecting flange with ¼" port for VGD20.xxxU	
AGF10.50U	Single 2" connecting flange with ¼" port for VGD20.xxxU	
AGA40.4050U	1" NPT vent connection plate for VGD40.xxxU	Each vent connection includes ¼" NPT test port, see Mounting instruction M7631.3 (74 319 0278 0)
AGA40.6580U	1 ¼" NPT vent connection plate for VGD40.xxxU	
AGA40.0100U	2" NPT vent connection plate for VGD40.xxxU	
AGA40.0150U	2 ½" NPT vent connection plate for VGD40.xxxU	

AGA61



Manual adjusting throttle attachment AGA61 permits VGDxx.xxxU series valves to be used as adjustable limiting orifice valves. Once adjusted, the AGA61 has a provision to be sealed from tampering.

AGA66



Sealing gasket to provide NEMA 3, NEMA 3R, and NEMA 4 protection.
 Gasket kit to mount SKPxx.xxxU

- Place between actuator SKPxx.xxxU and valve VGDxx.xxxU
- Increases degree of protection from IP54 to IP65
- Refer to Mounting Instruction M7643.2 (74 319 0421 0)

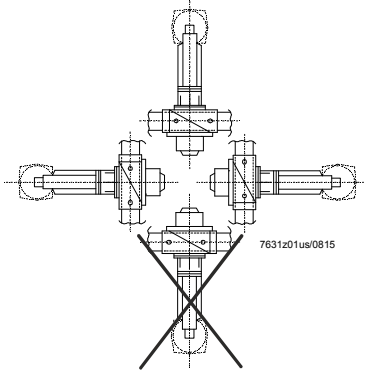
Specifications	Agency approvals/standards	UL/429, FM/7400, CSA/ANSI Z21.21/CSA 6.5 C / I
Approvals		IRI approvable Agency marks apply only for VGDxx.xxxU series gas valve bodies assembled with SKPxx.xxxU actuators.
Operating environment	Maximum operating pressure Maximum back pressure (differential) Close-off pressure Permissible gas temperature Permissible operating temperature	See <i>Table 2</i> VGD20.xxxU: 2 psi (150 mbar) VGD40.xxxU: 4 psi (300 mbar) See <i>Table 2</i> 14 °F to 140 °F (-10 °C to 60 °C) 14 °F to 140 °F (-10 °C to 60 °C)
Use	Siemens gas valves are in accordance with UL429. The valve is used as: - Safety shutoff valve (in connection with SKP15.xxxU) - Control valve with safety shutoff function (in connection with SKP25.xxxU, SKP5x.xxxU or SKP7x.xxxU)	
Perm. mounting position		
Operating pressure	See <i>Type summary</i>	
Types of gases	Suitable natural gases, propane, butane and air For more information see <i>Use</i> .	
Strainer	Built-in, mesh size 0.9 mm	

Specifications

Physical characteristics	Body materials	See Table 2
	Weight	See Tables 4
Connections	Pipe connections	NPT threads or ANSI class 150 flanges (see Table 2)
	Pressure and vent taps	See Tables 2 and 3

Operation All VGDxx.xxxU gas valves are normally closed, two-way valves. The valves have a standard, integral, stainless steel mesh filter (0.9 mm) in the inlet to protect the downstream components against contamination.

All valves have ¼ NPT ports for pressure test connection. A full size vent connection plate is available as an accessory for VGD40.xxxU valves.

See Table 2 and 3 for details on ports and vent connection plates.

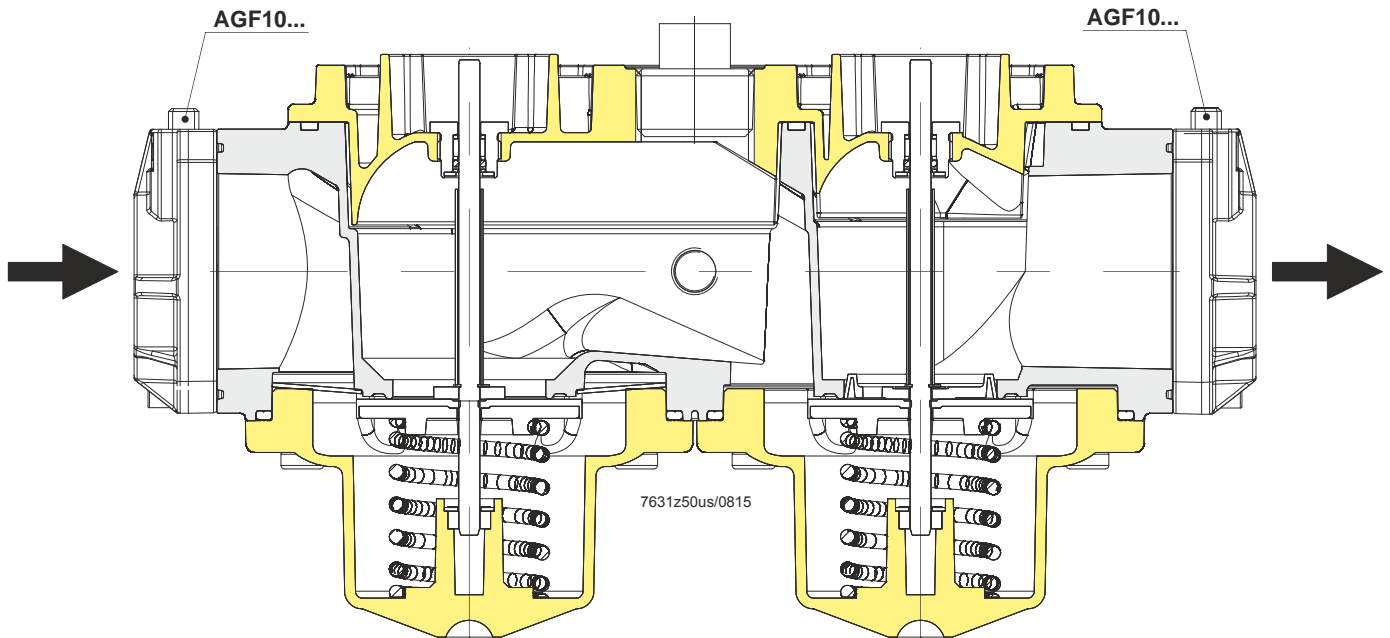

Figure 1. Sectional view of VGD20.xxxU

VGD20.xxxU double valves consist of two valves in series. The first (inlet) valve has a flat valve disc suitable for the safety shut-off function only. The second (outlet) valve has a contoured valve disc for stable regulating control and smooth release of gas.

Operation, continued

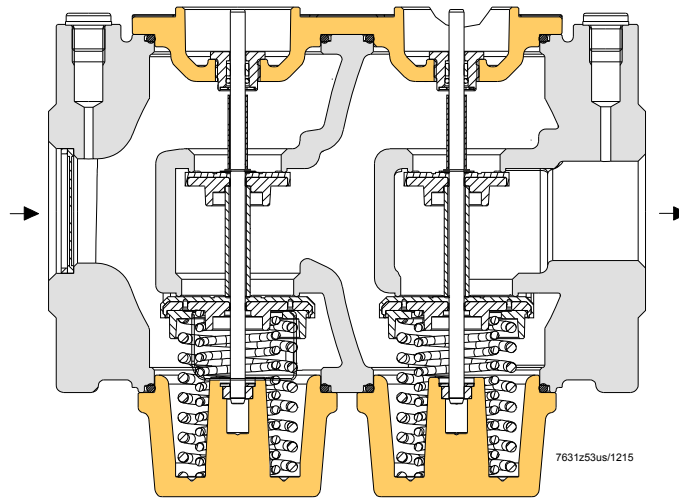

Figure 2. Second view of VGD40.xxxU flange models

VGD40.xxxU double valves consist of two valves in series.
Each valve has a double seat to achieve high flow (see *Figure 2*).

Closing springs:

Each double seat uses one pair of springs. The spring forces act separately as closing forces on the individual valve seats.

Gas flow charts

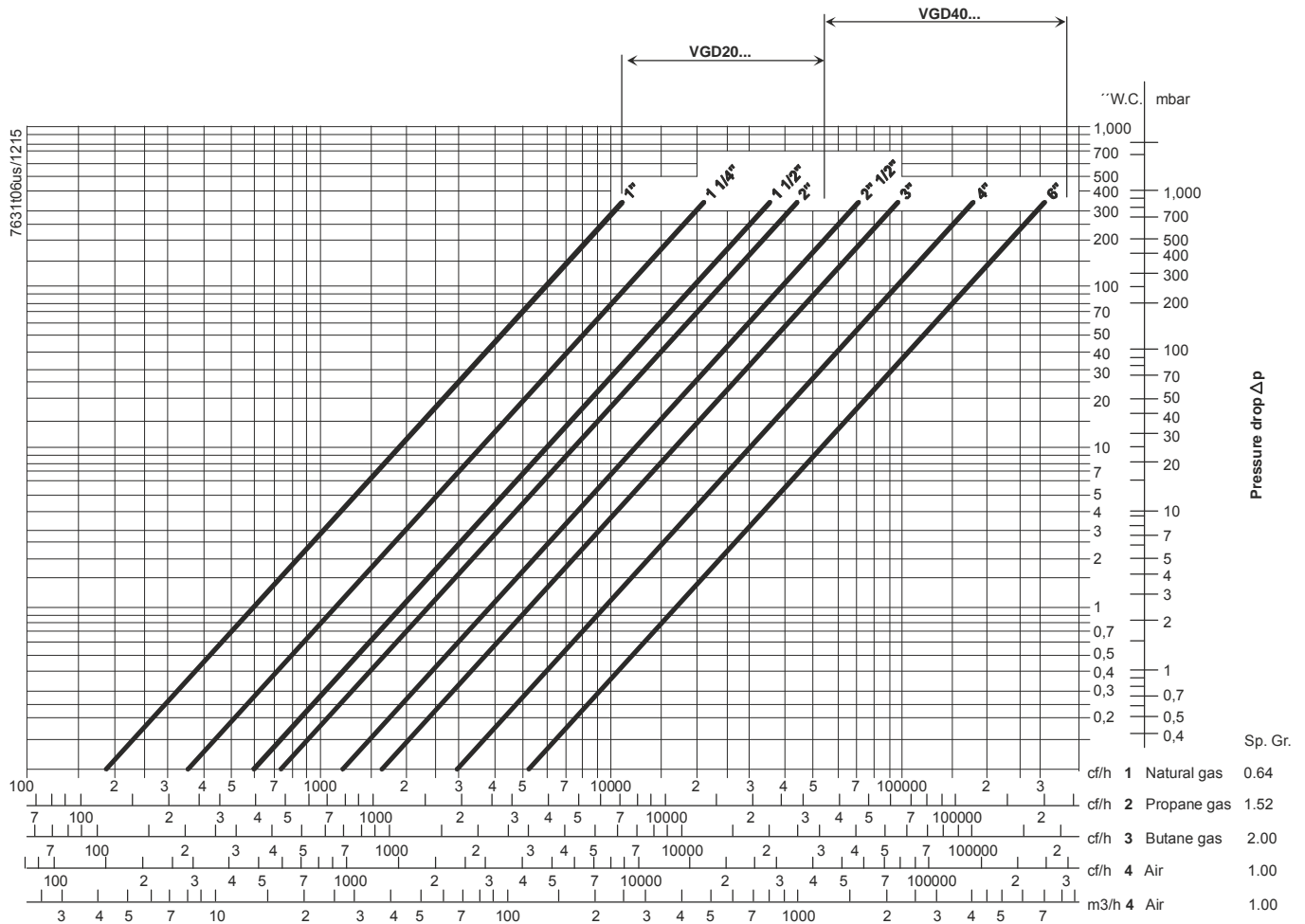

Figure 3. Sizing double valves

Assumptions:

- 1) Pressure downstream of valve is atmospheric
- 2) Maximum gas temperature of 140 °F
- 3) Valve in fully open position



NOTE:

Pressure drop is total drop across both valves when using a SKPx5.xxxU actuator, with or without an AGA66.



CAUTION:

Do not oversize valves equipped with regulating actuators SKP2x.xxxU, SKP5x.xxxU or SKP7x.xxxU. Oversizing may limit turndown and could cause oscillations.

Dimensions

Dimensions in Inches (mm)

VGD20.xxxU

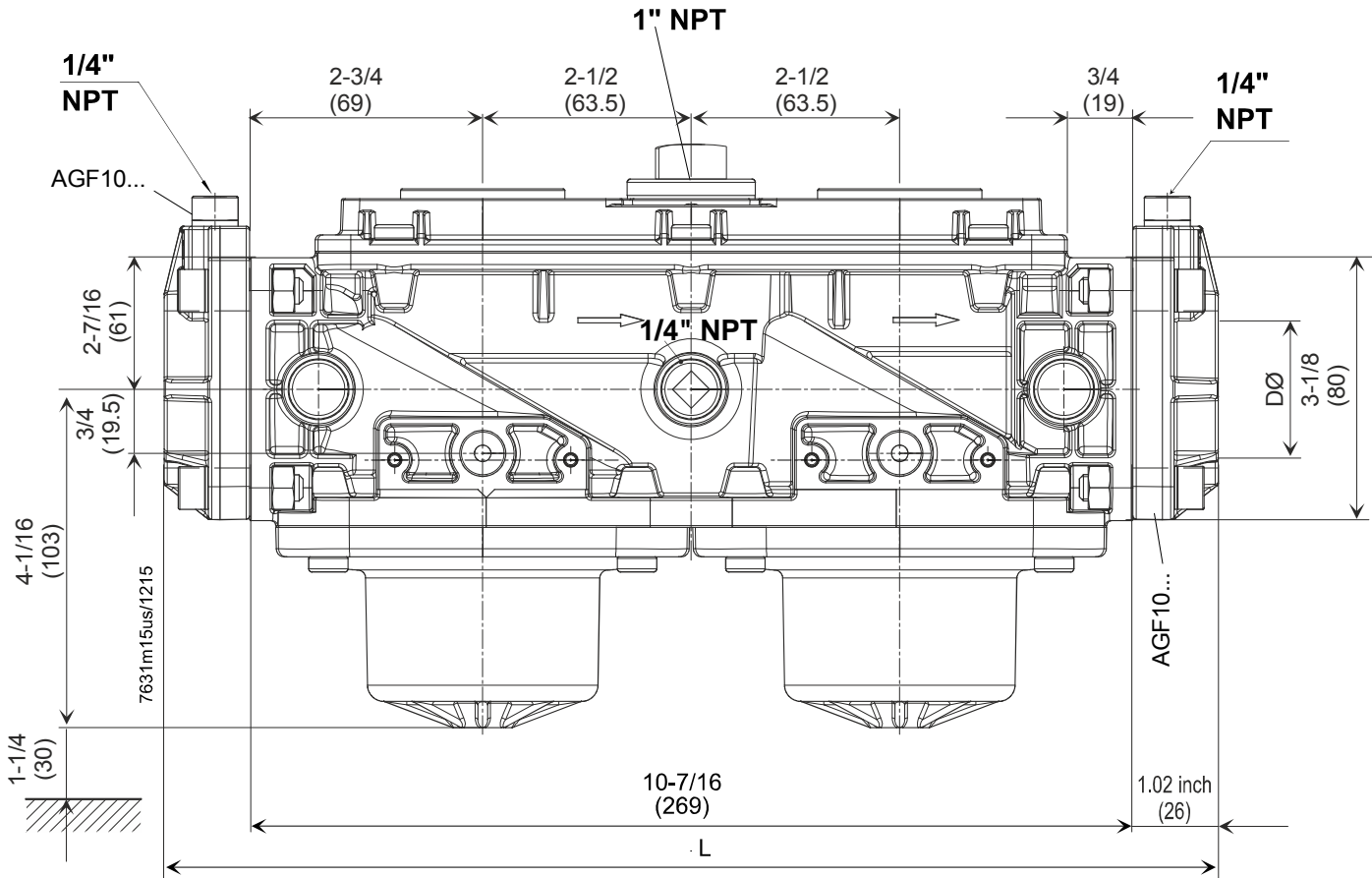

Table 4. VGD20.xxxU dimensions in inches (mm) with 2 flanges AGF10.xxU

Valve model	Nominal size D inch	Length (L) inch (mm)	Weight pounds (Kg)
VGD20.xxxU	1"	10.59 + 2 x 1.02 (269 + 2 x 26)	7 (3.2)
	1 ¼"	10.59 + 2 x 1.02 (269 + 2 x 26)	7 (3.2)
	1 ½"	10.59 + 2 x 1.02 (269 + 2 x 26)	7 (3.2)
	2"	10.59 + 2 x 1.18 (269 + 2 x 30)	7 (3.15)

Dimensions, continued

Dimensions in Inches (mm)

VGD40.065U / VGD40.080U

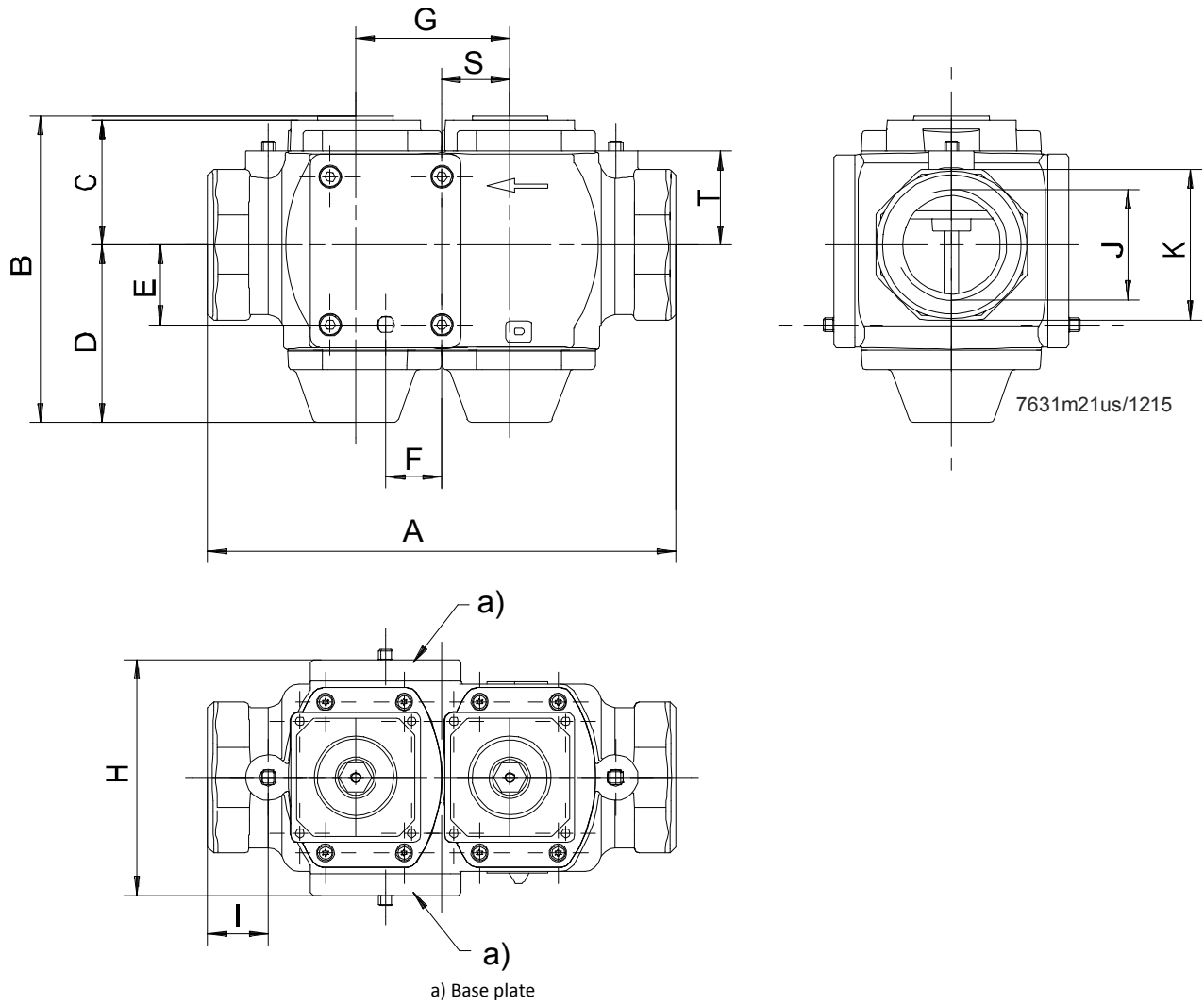

Dimensions, continued

Dimensions in Inches (mm)

VGD40.100U / VGD40.150U

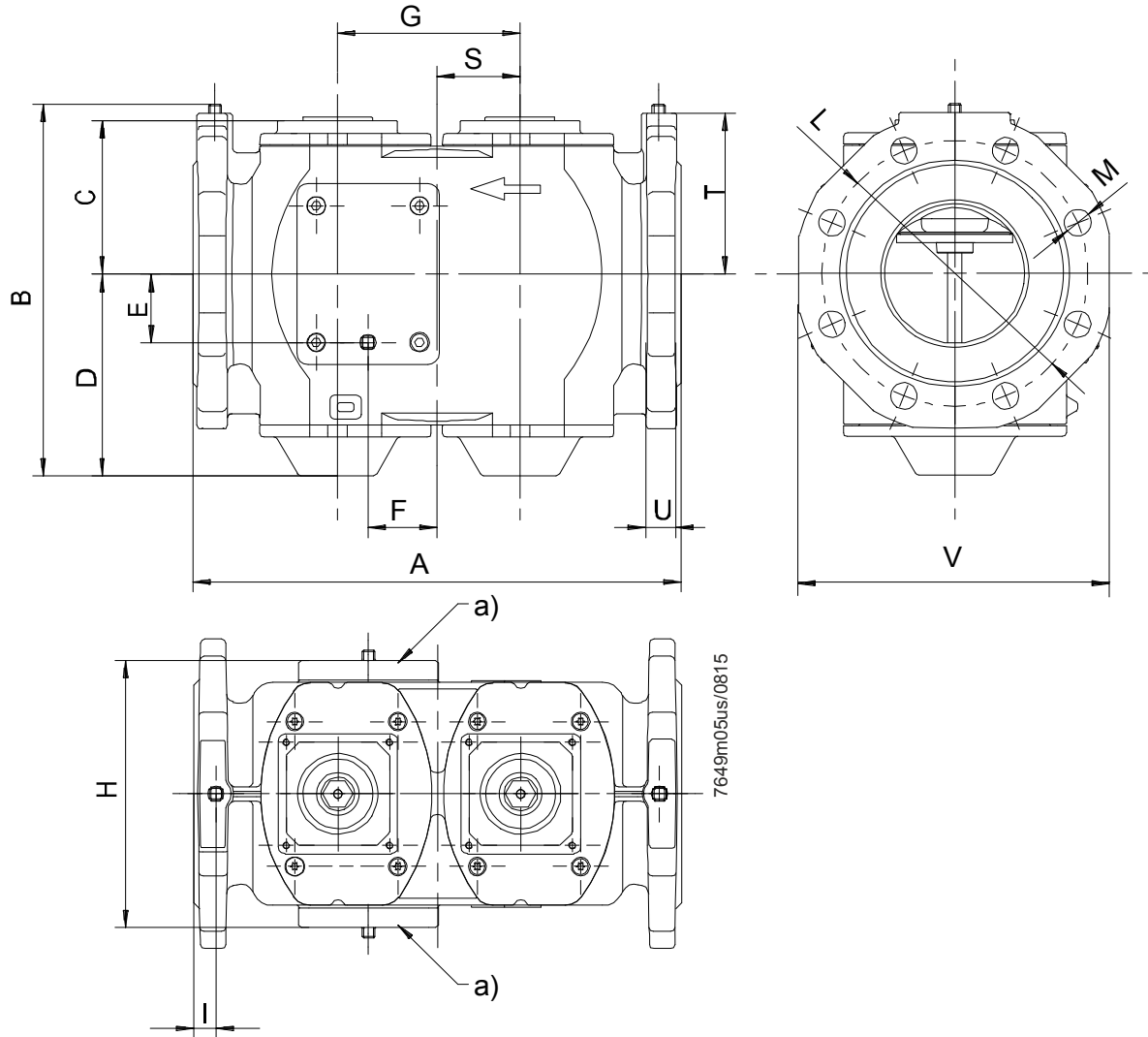

Table 5. VGD40.xxxU dimensions in inches (mm)

Type	A inch (mm)	B inch (mm)	C inch (mm)	D inch (mm)	E inch (mm)	F inch (mm)	G inch (mm)	H inch (mm)	I inch (mm)	J inch NPT	K (SW*) inch (mm)	L (d =) inch (mm)	M (d =) inch (mm)	S inch (mm)	T inch (mm)	U inch (mm)	V inch (mm)
VGD40.065U	11.42 (290)	8.54 (217)	3.25 (82.5)	4.63 (117.5)	2.09 (53.1)	1.46 (37)	4.02 (102)	6.14 (156)	0.63 (16)	2 ½"	4 (100)	5.5 (139.7)	0.75 (19)	1.77 (45)	3.64 (92.5)	0.80 (20.4)	7.01 (178)
VGD40.080U	12.20 (310)	9.39 (238.5)	3.64 (92.5)	5.18 (131.5)	2.09 (47)	0.79 (20)	4.21 (107)	6.30 (160)	0.63 (16)	3"	4.7 (120)	6.0 (152.4)	0.75 (19)	1.2 (30.5)	3.94 (100)	0.88 (22.4)	7.56 (192)
VGD40.100U	13.78 (350)	10.52 (267.3)	4.33 (110)	5.70 (144.8)	1.93 (49)	1.95 (49.5)	5.16 (131)	7.56 (192)	0.63 (16)	---	---	7.5 (190.5)	0.75 (19)	2.83 (72)	4.55 (115.5)	0.87 (22)	8.74 (222)
VGD40.150U	18.90 (480)	13.29 (337.5)	5.71 (145)	7.40 (188)	2.09 (53)	2.30 (58.5)	6.61 (168)	10.31 (262)	0.63 (16)	---	---	9.5 (241)	0.91 (23)	3.92 (99.5)	5.61 (142.5)	0.90 (22.9)	10.63 (270)

*) SW = width across flats

Dimensions, continued

Dimensions in Inches (mm)

VGD40.xxxU valve with vent connection plate

- Option: a) Base plate
 b) Vent connection plate AGA40.xxxxU (optional) to be ordered separately
 a) and b) are interchangeable

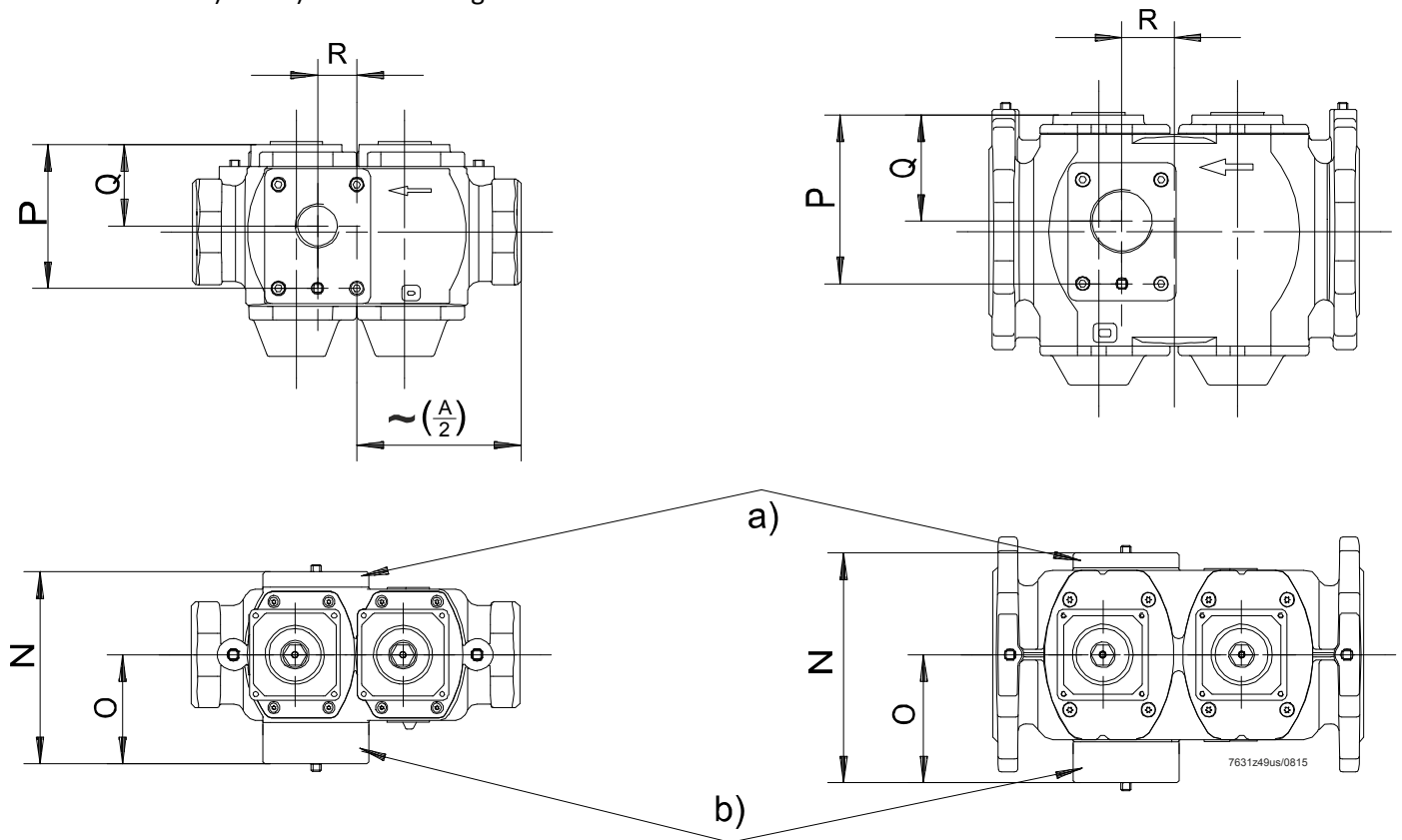

Table 6. VGD40.xxxU dimensions in inches (mm) with mounted vent connecting plate.

Valve model	N inch (mm)	O inch (mm)	P inch (mm)	Q inch (mm)	R inch (mm)	Weight pounds (kg)
VGD40.065U	7.13 (181)	4.06 (103)	5.34 (135.6)	3.02 (76.59)	1.46 (37)	1.6 (7)
VGD40.080U	7.28 (185)	4.13 (105)	5.49 (139.5)	3.17 (80.5)	0.79 (20)	19 (8)
VGD40.100U	8.54 (210)	4.76 (121)	6.26 (159)	3.94 (100)	1.95 (49.5)	29 (13)
VGD40.150U	11.30 (287)	6.14 (156)	7.80 (198)	5.47 (139)	2.28 (58)	53 (24)

Dimensions, continued

Table 7. AGA40.xxxxU Models

Vent connection plate (optional)					
	VGD40.065U	VGD40.080U	VGD40.100U	VGD40.150U	Vent connection thread "Z"
AGA40.6580U	●	●			1¼" NPT
AGA40.0100U			●		2" NPT
AGA40.0150U				●	2½" NPT

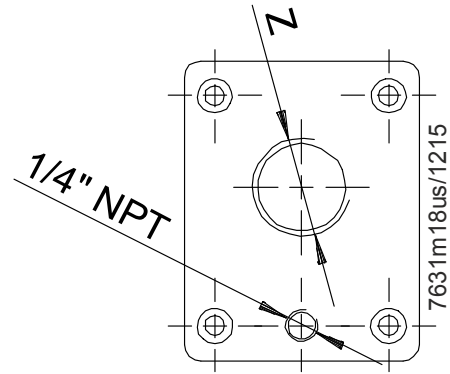

Information in this publication is based on current specifications. The company reserves the right to make changes in specifications and models as design improvements are introduced. Other product or company names mentioned herein may be the trademarks of their respective owners.

Siemens AG Building Technologies Division
 Berliner Ring 23
 76437 Rastatt
 GERMANY

Your feedback is important to us. If you have comments about this document, please send them to techsupport@SCCcombustion.com

Document No. CC1N7631us
 Country of Origin: DE