

TS Series

TS-MS... Master Lead/Lag Panels for Boiler Management, and Building Management System Interface

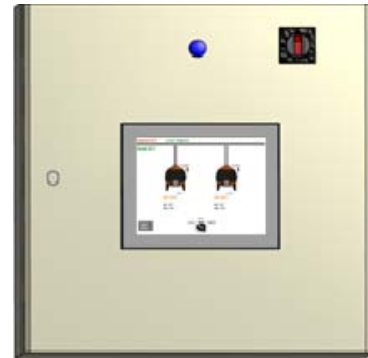

Description

A TS-MS... series Master Lead/Lag Panel sequences and controls up to eight boilers equipped with TS... communication kits and/or TS... combustion enclosures. TS-MS... Master Panel options include communication to TS-D... Deaerator/Surge panel control systems.

A Master Panel controls hot water or steam boilers with Siemens LMV linkageless control systems, with or without an RWF... controller for load or water level control. Each panel includes a 7", 10", or 12" touchscreen and programmable logic controller (PLC).

Flexible communication interface options to the building management system (BMS) provide streamlined data collection, monitoring, and control. Additional options include control of circulating pumps, analog input monitoring for hot water boilers, or temperature monitoring for steam boilers.

Standard Features

- 7", 10" or 12" touchscreen
- Programmable Logic Controller (PLC)
- Manages up to eight (8) boilers with Siemens LMV... controllers
- Lead/lag with automatic boiler rotation
- Lead and lag boiler order selection
- Parallel, sequential, or parallel PV, modulation
- Remote enable and setpoint adjustment via BMS
- Time / temperature based hot standby
- Low temperature / low fire hold
- System steam flow or MBTU totalization based upon firing rate
- Controlling systems with combination of TS... touchscreen kits or TS... serial kits at each boiler with Siemens LMV linkageless systems
- Control system with or without the RWF for water level control or RWF55 for load control
- Water level monitoring with RWF55 loop controllers
- Forced lead boiler selection
- Forced lead boiler to stop boiler rotation
- Forced boiler not to be the lead boiler
- Forced number of boilers in lead lag rotation
- Forced individual boilers to lower firing rate, when boiler pressure exceeds setpoint plus an offset LFH
- Hand-Off-Auto selection
- Override setpoint mode via a digital input
- Boiler firing based on predetermined daily schedule
- Individual boiler alarms and status
- Graphics for individual boiler overview screens are configured based on Master Panel selections
- Individual boiler or master touchscreen graphics capture to USB drive
- Monitored digital outputs can be configured to take action based upon the value in any of the Modbus registers
- Standard or Metric units display
- English or Spanish language options
- Twelve (12) selectable data logging variables stored in CSV format on USB drive
- Real time trending and data logging to a USB thumb drive
- Six (6) selectable variables for trending up to 7 days
- Alarm history stored for most recent 250 alarms
- Screen saver with process variable (PV), setpoint, and demand
- Ethernet and serial communications to local boilers
- Standard Modbus TCP/IP or RTU to BMS communications

- Additional BMS communication options available
- Email and text messaging includes alarms and screen shots for up to six (6) recipients
- Screen shot viewer via USB
- Remote monitoring via smartphone or tablet
- Interface to SCC Deaerator/Surge tank control panel
- Short cut navigation from the overview screen
- Multi-level, password protected screens
- Four (4) analog inputs with field configurable label, span, and type (0-10V, 2-10V, 0-20mA or 4-20mA). Each with low and high alarm setpoints, with auto or manual reset. Totalization available per minute or per hour. Optional for hot water boilers
- Two (2) analog outputs with field configurable span and type (0-10V, 2-10V, 0-20mA or 4-20mA). Each with low and high alarm setpoints, with auto or manual reset. Totalization available per minute or per hour. Optional with the analog input module selection for hot water boilers
- Four (4) Pt1000 (or Pt100) RTD temperature inputs with field configurable label. Each with low and high alarm setpoints, with auto or manual reset. Optional for steam boilers
- Four (4) digital outputs with field configurable logic, including on and off delays. Manual or automatic reset
- Outside air reset for hot water boilers
- Individual circulating pump control outputs for hot water boilers

Application

TS-MS Lead/Lag Panels are engineered for hot water boilers, steam boilers, or other applications utilizing LMV3 or LMV5 linkageless control systems, with or without RWF, for load or water level controls.

Components

All TS-MS... Master Panels include the following components:

- 7", 10" or 12" touchscreen
- Programmable Logic Controller (PLC)
- Power supply and branch circuit protection
- Digital, analog, and RTD input modules
- Analog and digital inputs and outputs
- Interconnect terminals for field wiring

Product Part Numbers

Master Lead/Lag panel part number identification.

	TS	-	MS	8	1	0	S	-	S	X	X
Touchscreen											
Master Lead/Lag											
Number Of Boilers											
4 = Up to four boilers and SCC DA/Surge Panel											
5 = Up to five boilers											
7 = Up to seven boilers and SCC DA/Surge Panel											
8 = Up to eight boilers											
9 = Up to eight boilers and SCC DA/Surge Panel											
Enclosure											
1 = NEMA 1											
2 = NEMA 12, includes cover over the touchscreen											
4 = NEMA 4X											
A = NEMA 1 with cooling fan											
B = NEMA 12 with cooling fan, includes cover over touchscreen and fan											
C = NEMA 4X with cooling fan, includes cover over fan											
Touchscreen Size											
7 = 7.0" touchscreen											
0 = 10" touchscreen											
2 = 12" touchscreen											
BMS Communication											
S = Modbus TCP/IP and Modbus RTU 485											
B = BACnet/IP or Ethernet/IP											
L = LonWorks											
M = BACnet MS/TP, or Johnson Metasys N2											
N = Profinet											
P = Profibus											
Application											
S = Steam boilers with TS touchscreen kits at each boiler											
H = Hot water boilers with TS touchscreen kits at each boiler											
R = Steam boilers with serial kits at each boiler											
W = Hot water with serial kits at each boiler											
U = Universal steam boilers with TS touchscreen kits and serial kits at each boiler											
Z = Universal hot water boilers with TS touchscreen kits and serial kits at each boiler											
Temperature Measurement for Steam Boilers or Analog Measurement for Hot Water Boilers											
T = 4 Platinum 100/1000 Ohms RTD inputs (only for selection S, R, or U application above)											
A = 4 analog inputs module (only for selection H, W, or Z application above)											
X = None											
Circulating Pump Controls (Hot water applications H,W, or Z only)											
P = Circulating pump controls (based on number of hot water boilers selected above)											
X = None											

Specifications

		7" Touchscreen	10" Touchscreen	12" Touchscreen
Electrical Characteristics	Operating Voltage	110-120 VAC	110-120 VAC	110-120 VAC
	Operating Frequency	50-60 HZ	50-60 HZ	50-60 HZ
	Power Consumption Full Load	360VA	360VA	360VA
	TS Touchscreen Power	24 VDC	24 VDC	24 VDC
	TS Power Consumption	≤ 6.8 W	≤ 17 W	≤ 19 W
	Dry Contacts	2 Amps	2 Amps	2 Amps
Operating Environment	Operating Temperature	32 to 122 °F [0 to 50 °C]	32 to 131 °F [0 to 55 °C]	32 to 131 °F [0 to 55 °C]
	Humidity	Max. 80% with no condensation	Max. 85% with no condensation	Max. 85% with no condensation
	NEMA Rating (Standard)	1	1	1
	NEMA Rating (Optional)	4-4X Indoor NEMA 12	4-4X Indoor NEMA 12	4-4X Indoor NEMA 12
Field Cables (By others)	Between Master and Boiler Touchscreens	CAT5e-CAT6-CAT6e-CAT7		
	Between Master and Serial Kits (no touchscreens)	Belden 3106A recommended		
BMS Cable Length	Modbus RTU RS-232 Connection	Up to 15 feet		
	Modbus RTU RS-485 Connection	Up to 1500 feet		
	All Other Protocols	Adhere to BMS protocol wiring specifications		

Specifications (continued)

Note: For all RS-485 connections, use Belden Cable 3106A (multi-conductor cable with twisted pair, EIA Industrial RS-485 PLTC/COM) or equivalent.

Table 1: Belden Cable 3106A Wire Color Designation

Electrical Diagram	Belden Cable 3106A
Red (RS485+)	Orange (RS485+)
Black (RS485-)	White (RS485-)
White (SG)	Blue (SG)

Connections

Power Connections

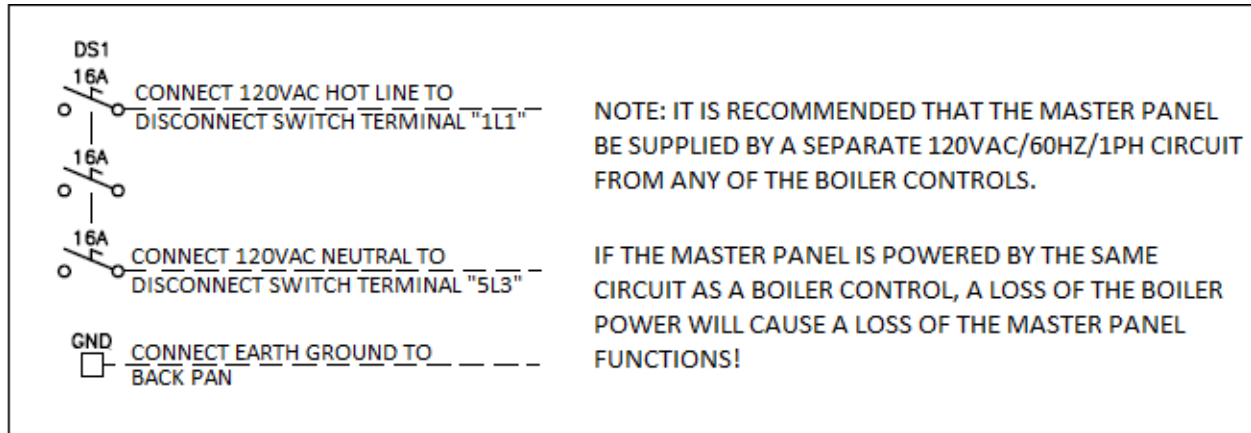

Digital Input Remote Control Terminals

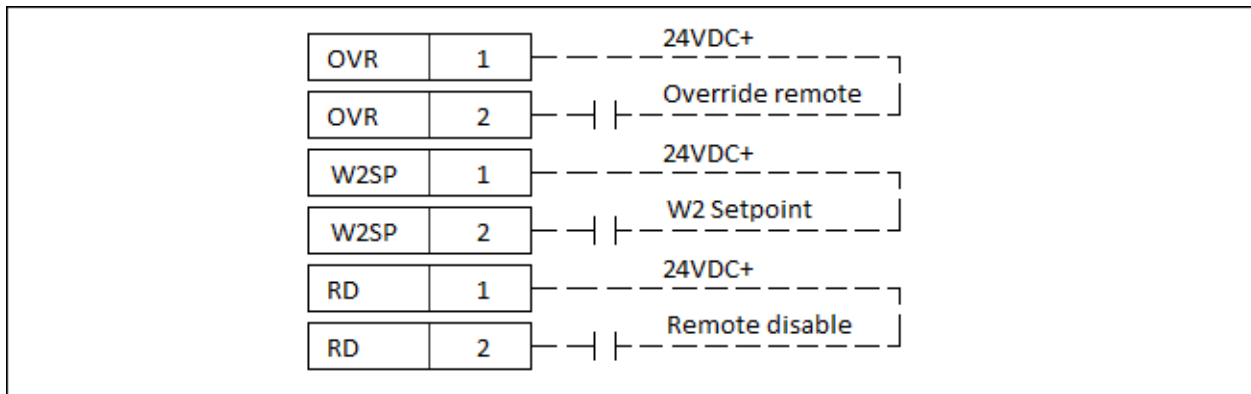

Outputs Monitored Value Terminals

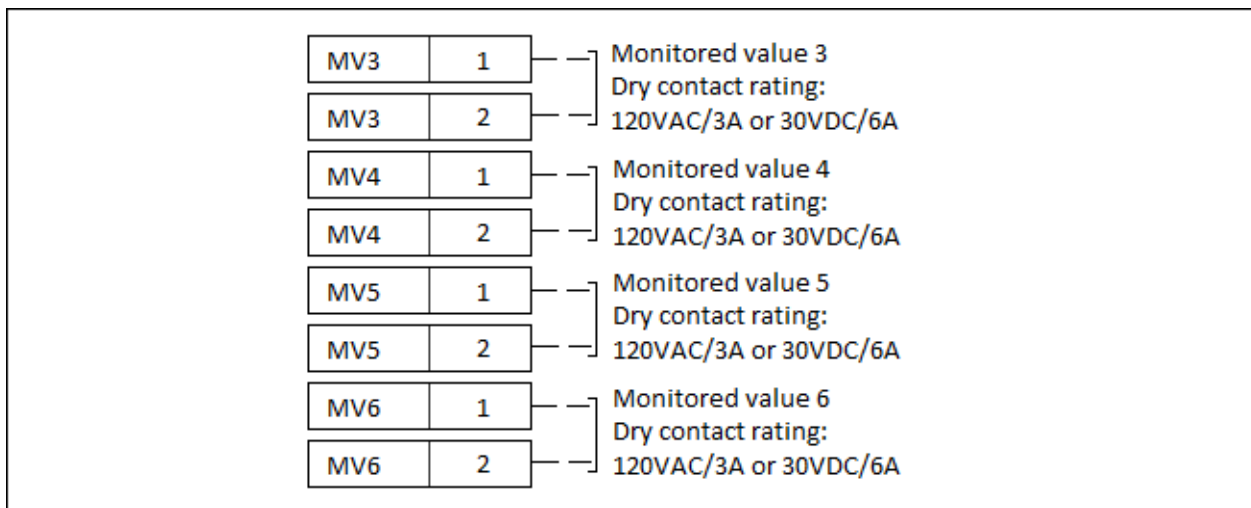

Connections (continued)

PLC output alarm terminals

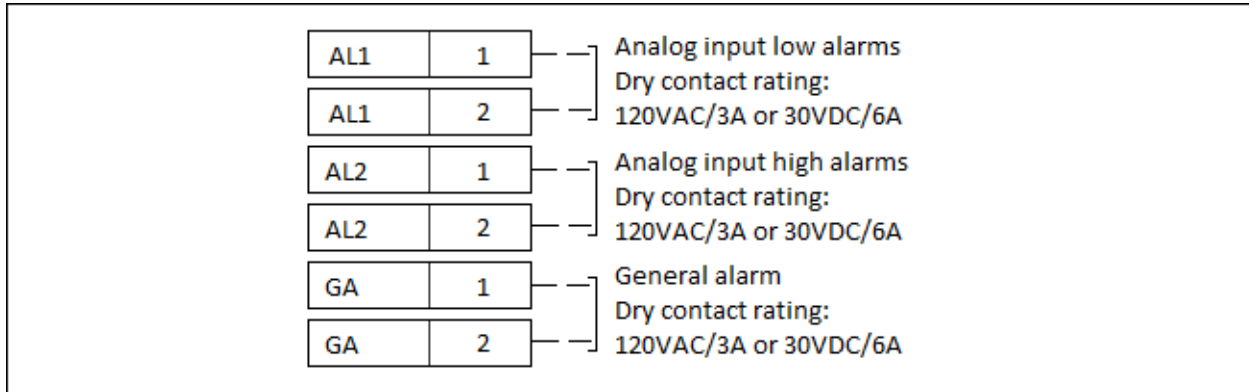

Hot Water Boilers Only (Application H, W or Z): Digital Input Pump Proven Terminals

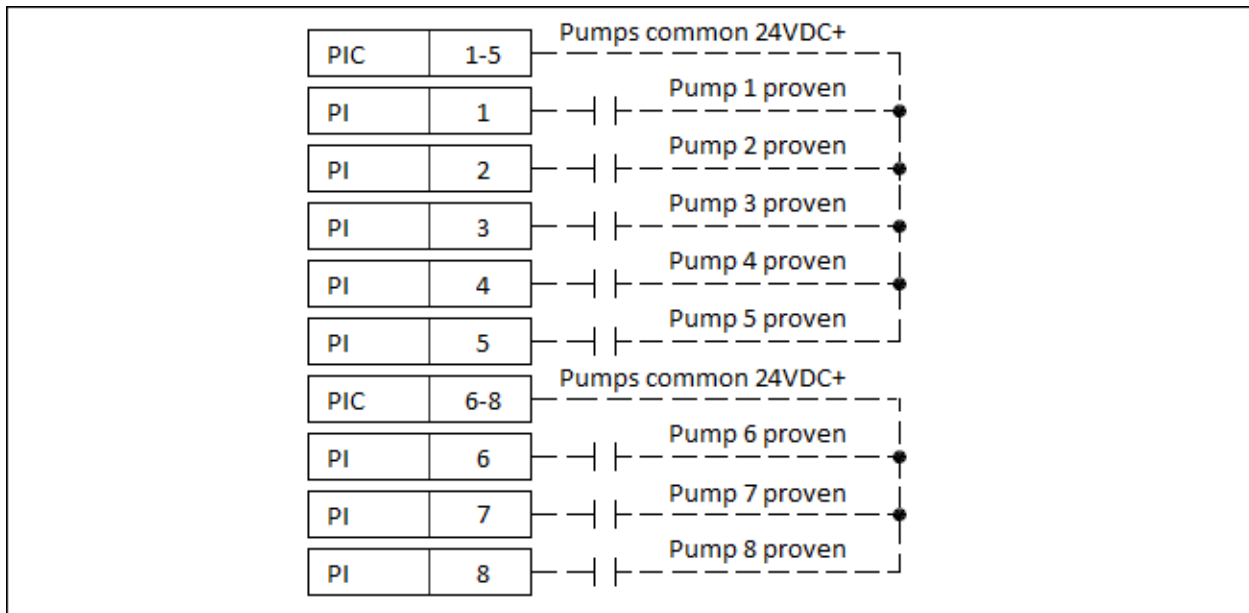

Note: Number of boilers in the part number corresponds to the number of wired digital inputs for pump proven terminals

Connections (continued)

Hot Water Boilers Only (Application H, W, or Z): Digital Output Pump Control Terminals

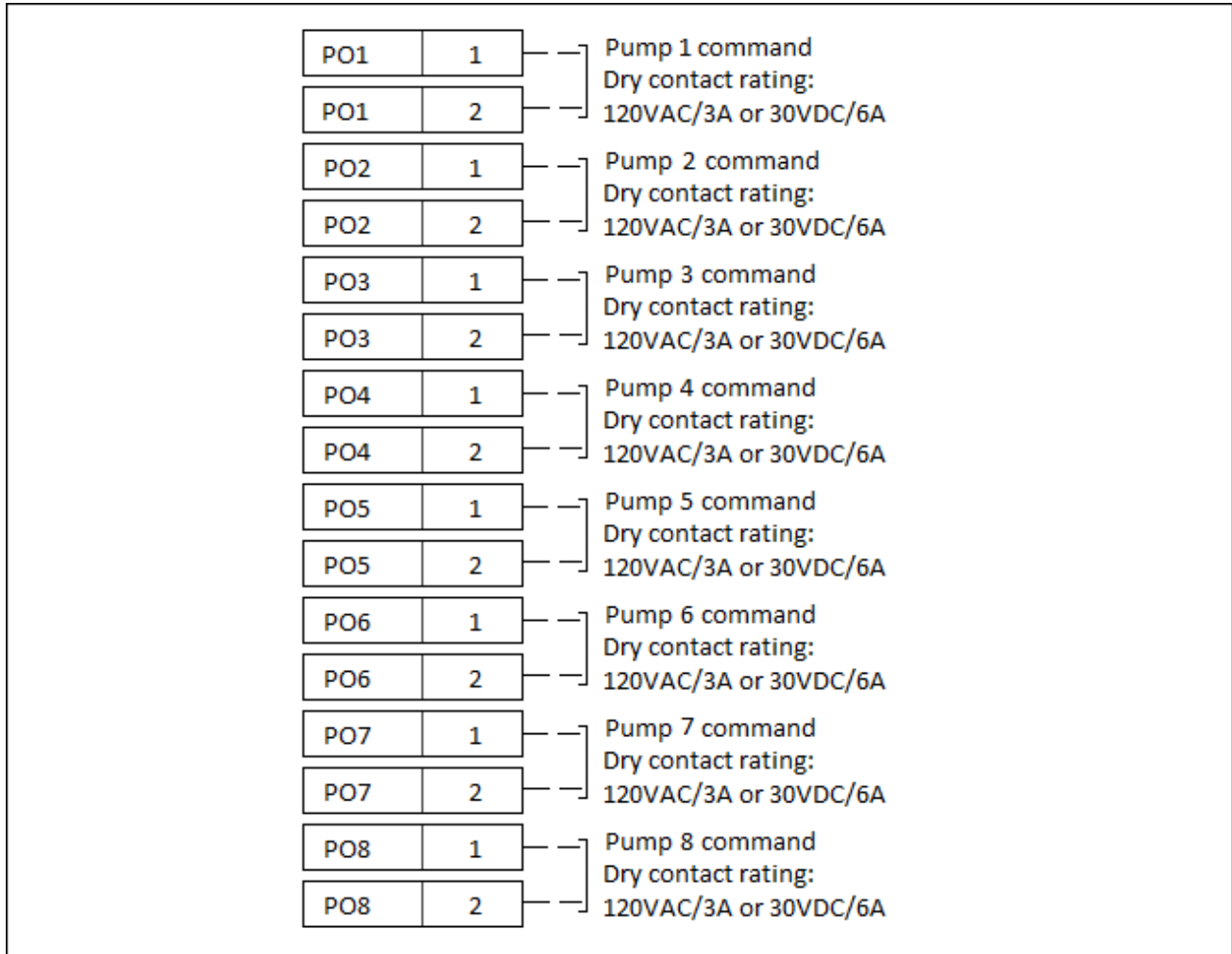

Note: Number of boilers in the part number corresponds to the number of wired digital outputs for pump control terminals

Connections (continued)

Analog Input and Output Terminals (one module)

- Standard for Steam Boilers (Application S, R, or U)
- Optional for Hot Water Boilers (Application H, W or Z)

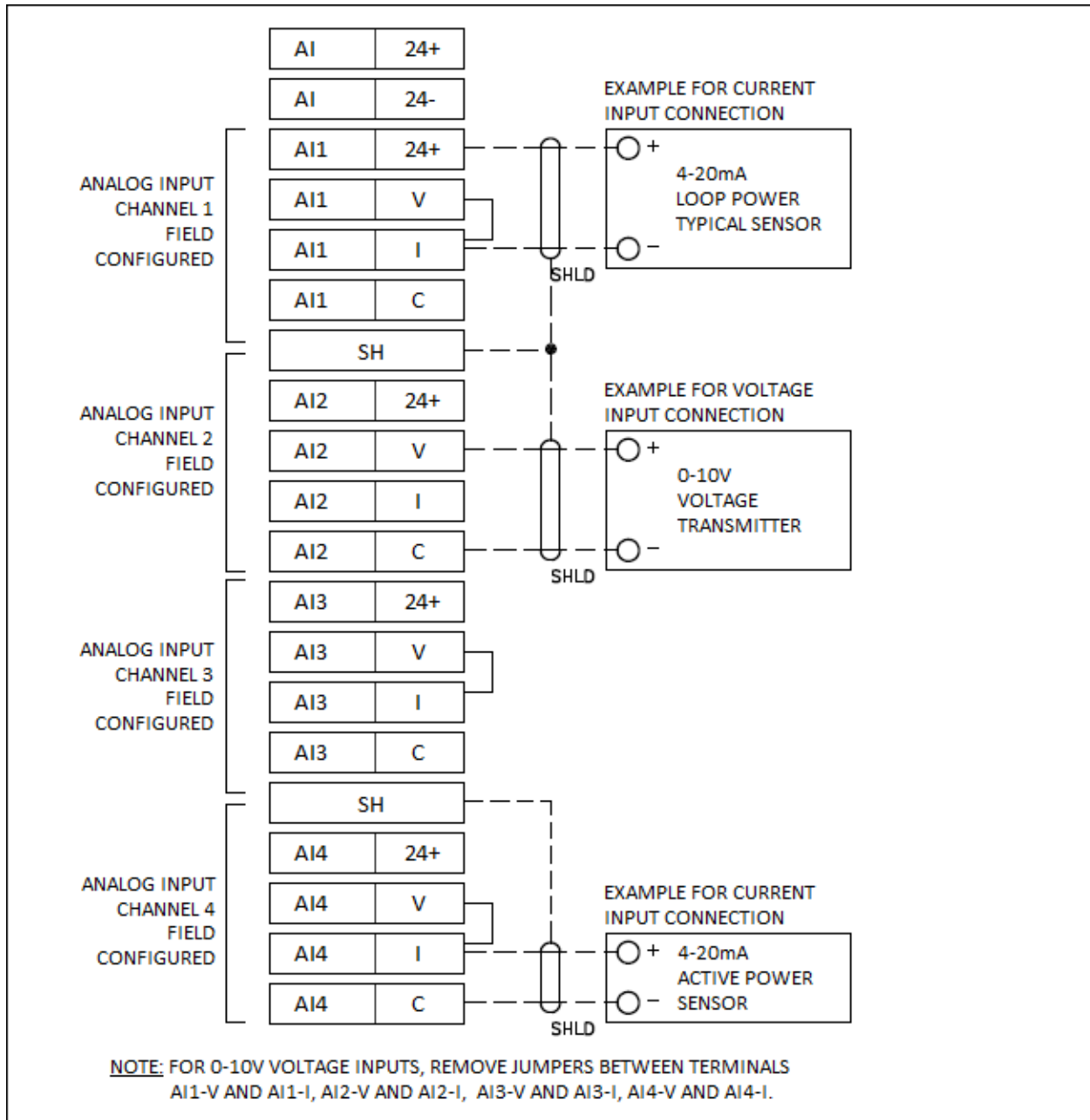

Connections (continued)

Analog Input and Output Terminals (one module) continued

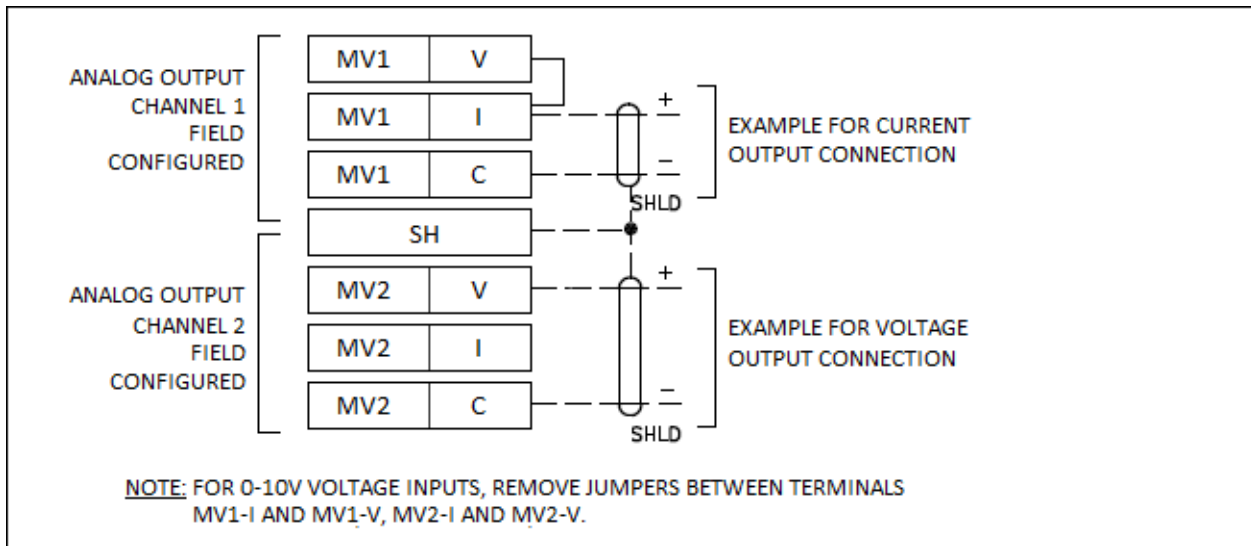

Connections (continued)

RTD Input Terminals

- Standard for Hot Water Boilers (Application H, W or Z)
- Optional for Steam Boilers (Application S, R, or U)

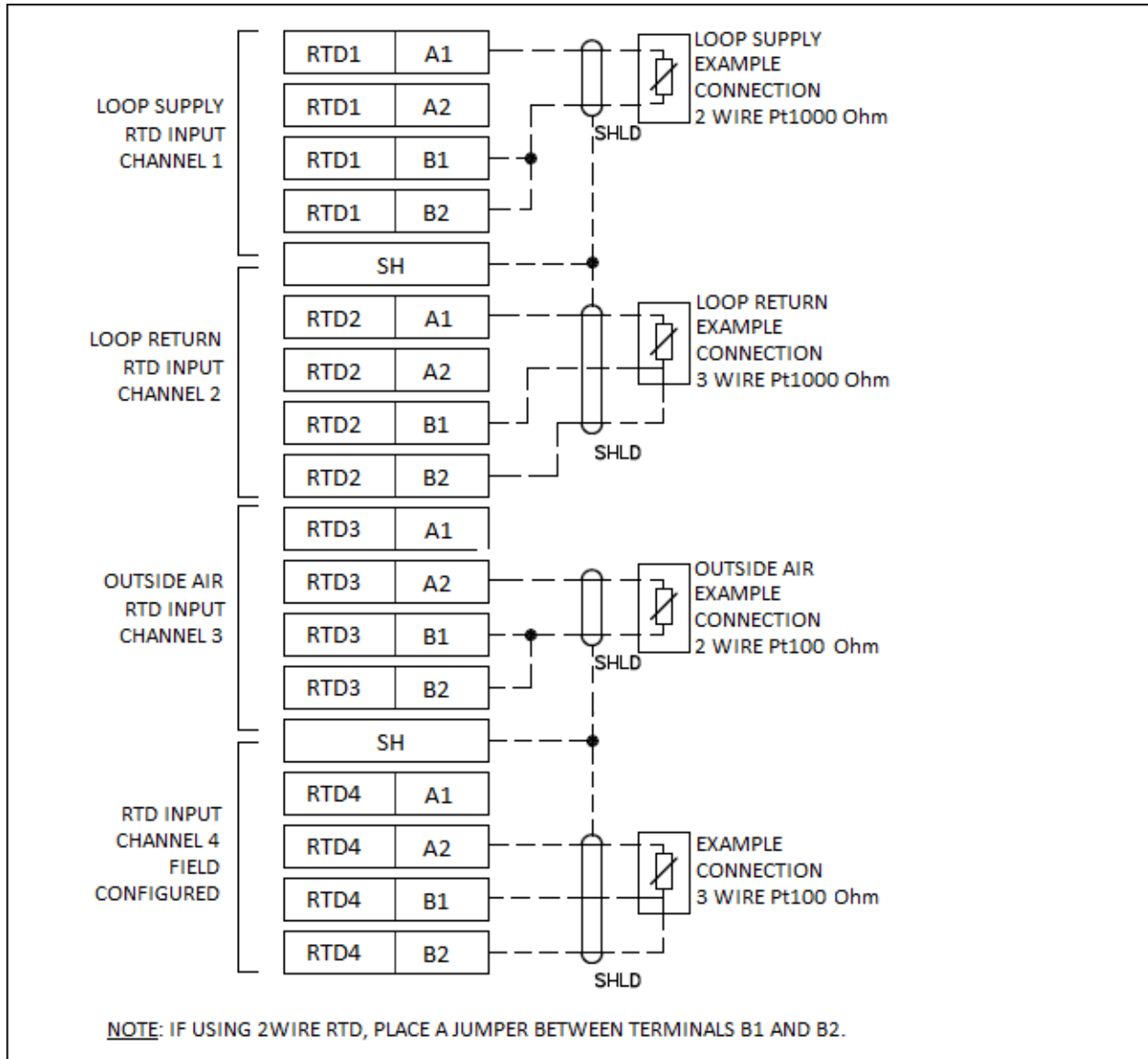

Connections (continued)

RTD Input Terminals

- Optional for Steam Boilers (Application S, R, or U)

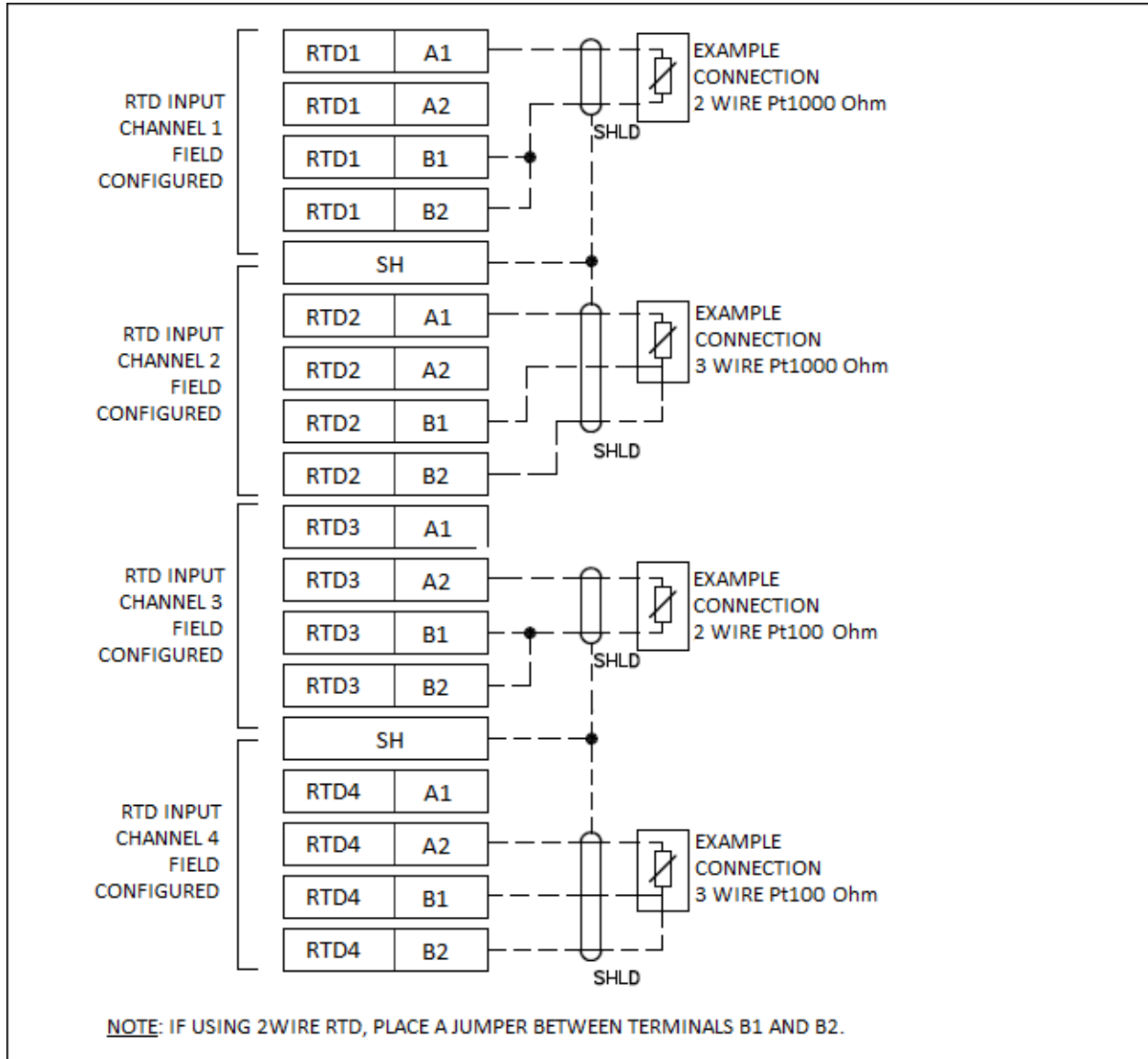

Connections (continued)

Ethernet connection with TS kits at each boiler and Deaerator/Surge control system (if applicable)

- Ethernet connections for up to 5 TS kits, or up to 4 TS kits with SCC Deaerator/Surge control system. Ethernet cables not included.

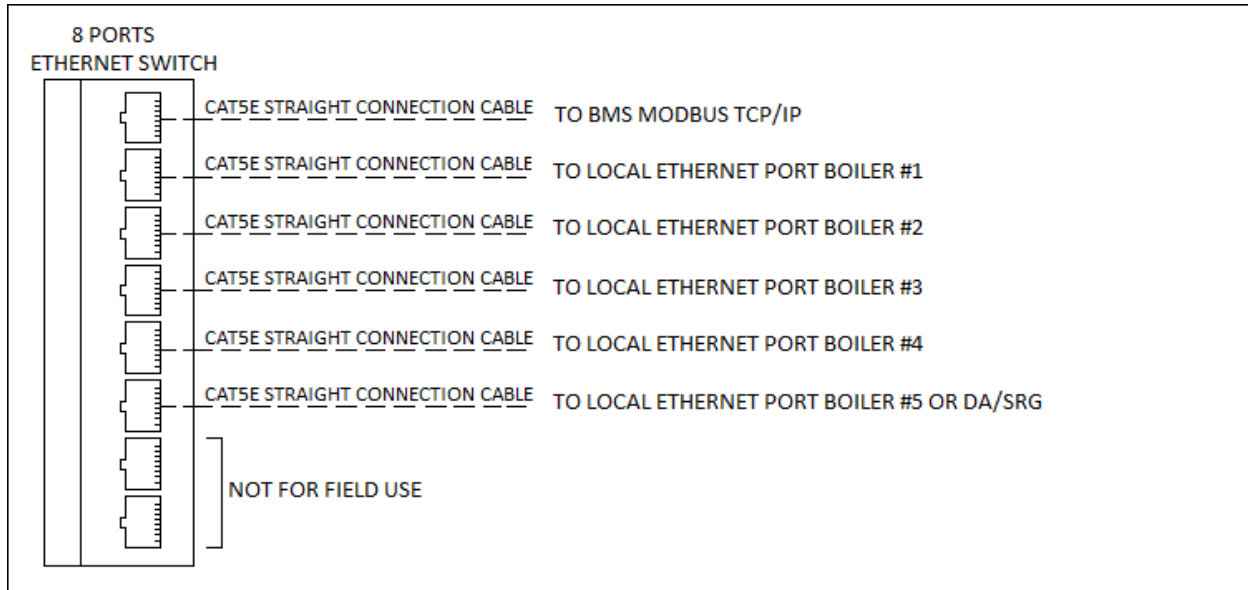

NOTE 1: Wire all CAT5e cables separately from AC power wires.

Note 2: If a second DA or second Surge tank SCC control panel connection required, the maximum boiler connections will be reduced by one.

Connections (continued)

Ethernet connections for up to 8 TS kits, or up to 7 TS kits with Deaerator/Surge control system.
 Ethernet cables not included.

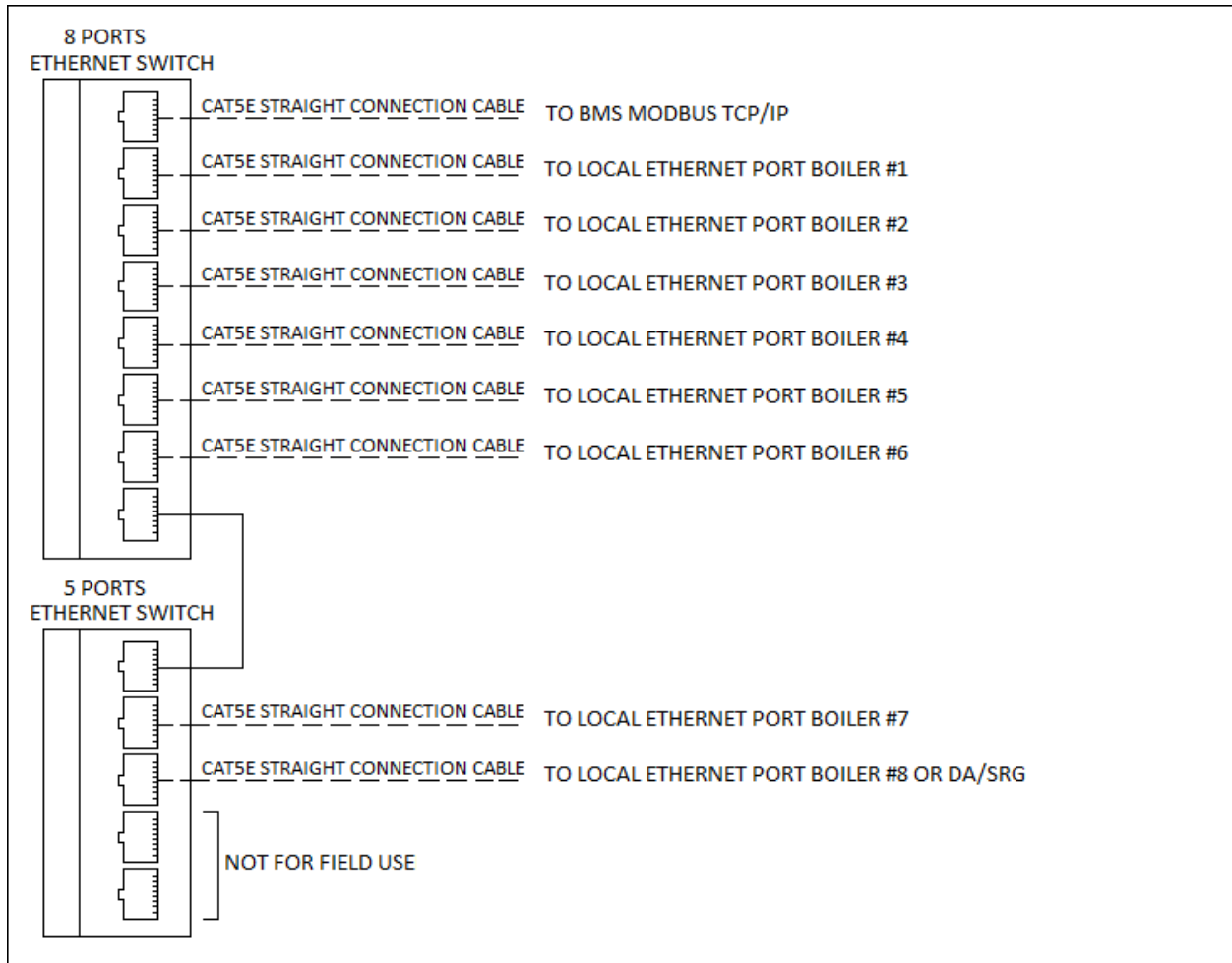

NOTE 1: Wire all CAT5e cables separately from AC power wires.

Note 2: If a second DA or second Surge tank SCC control panel connection required, the maximum boiler connections will be reduced by one.

Connections (continued)

Ethernet connection for up to 8 TS kits and Deaerator/Surge control system. Ethernet cables not included.

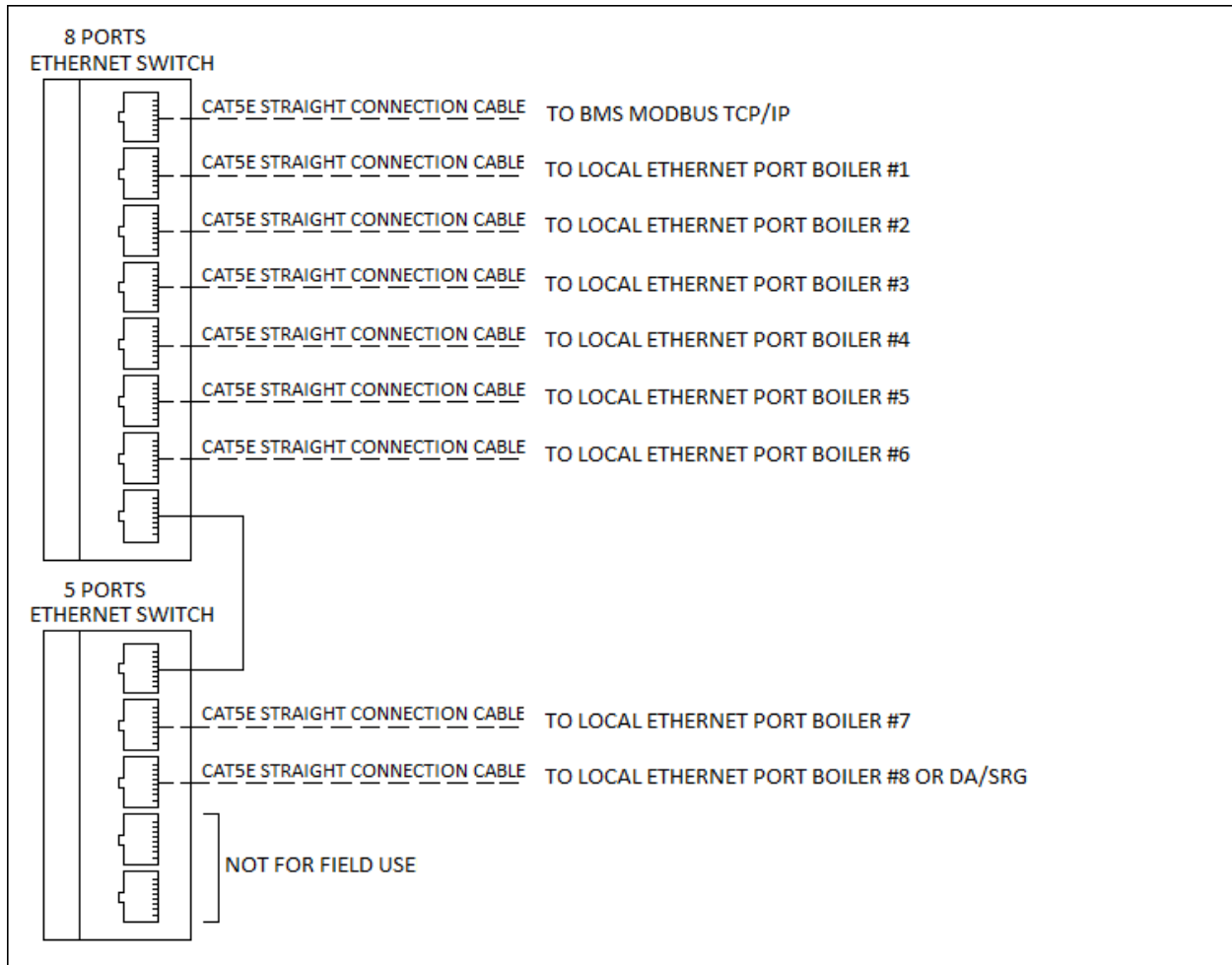

NOTE 1: Wire all CAT5e cables separately from AC power wires.

Note 2: If a second DA or second Surge tank SCC control panel connection required, the maximum boiler connections will be reduced by one.

Connections (continued)

Modbus RS-485 serial connections with LMV52 serial kits (no touchscreen at each boiler). Shielded cables not included.

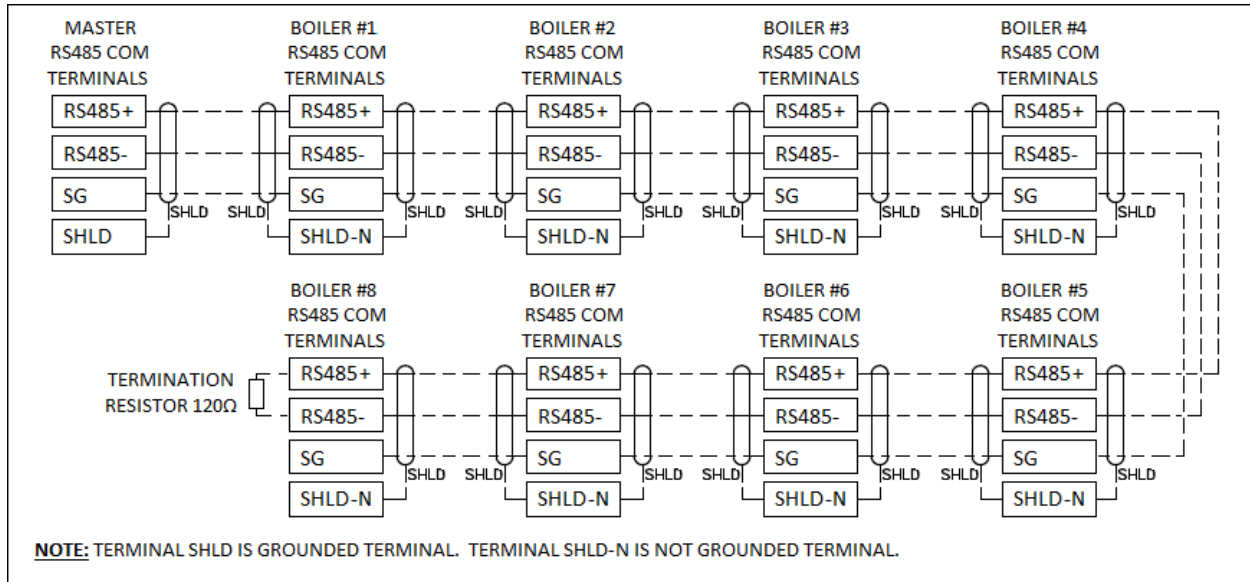

Connections (continued)

Modbus RS-485 serial connection with LMV51 serial kits (no touchscreen at each boiler), and with RWF55 as load controller (LC)

OR

Modbus RS-485 serial connection with LMV52/51 serial kits (no touchscreen at each boiler), and with RWF55 as water level controller (WL)

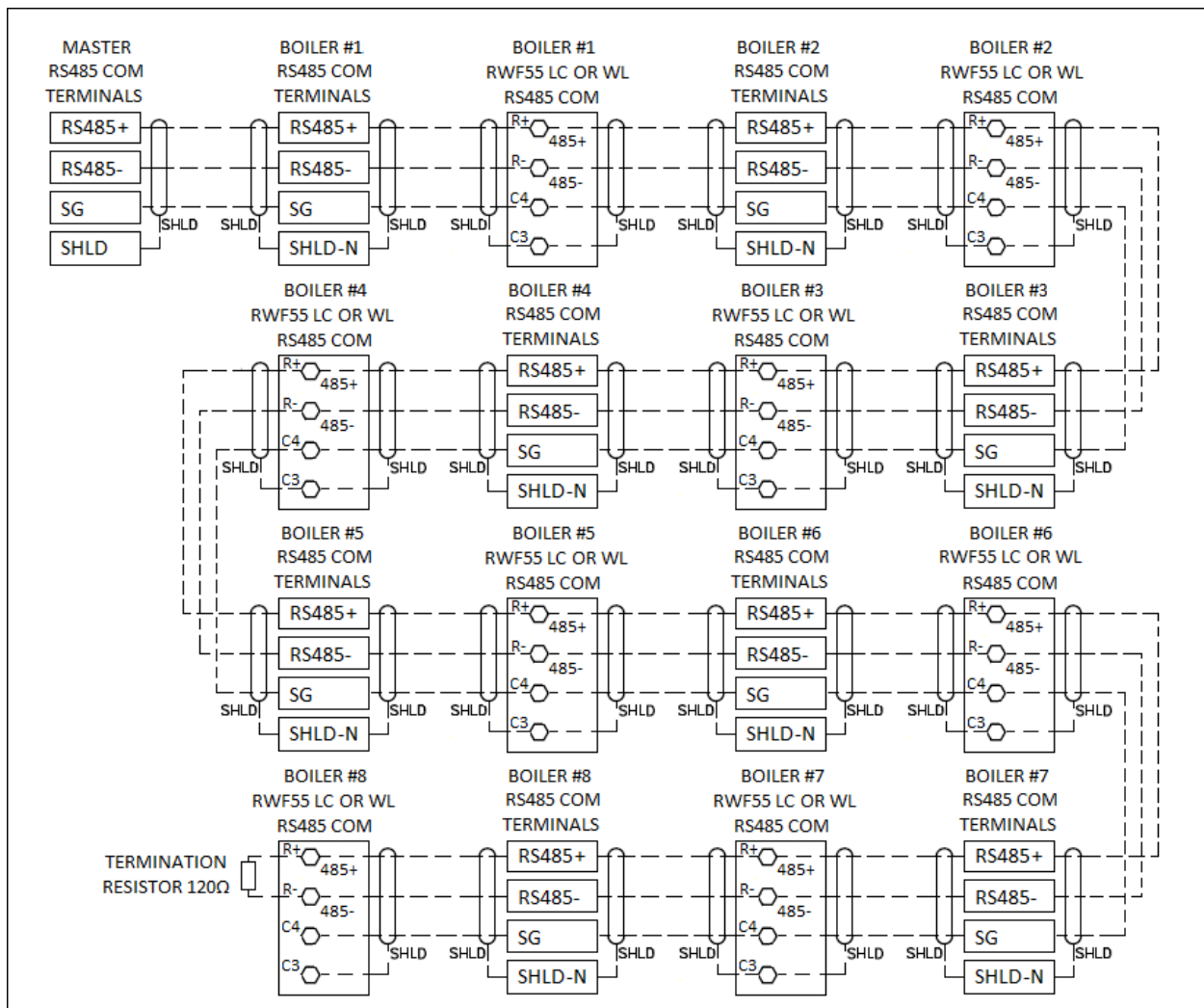

Connections (continued)

Modbus RS-485 serial connection with LMV3x serial kits (no touchscreen at each boiler), and with RWF55 as load controller (LC)

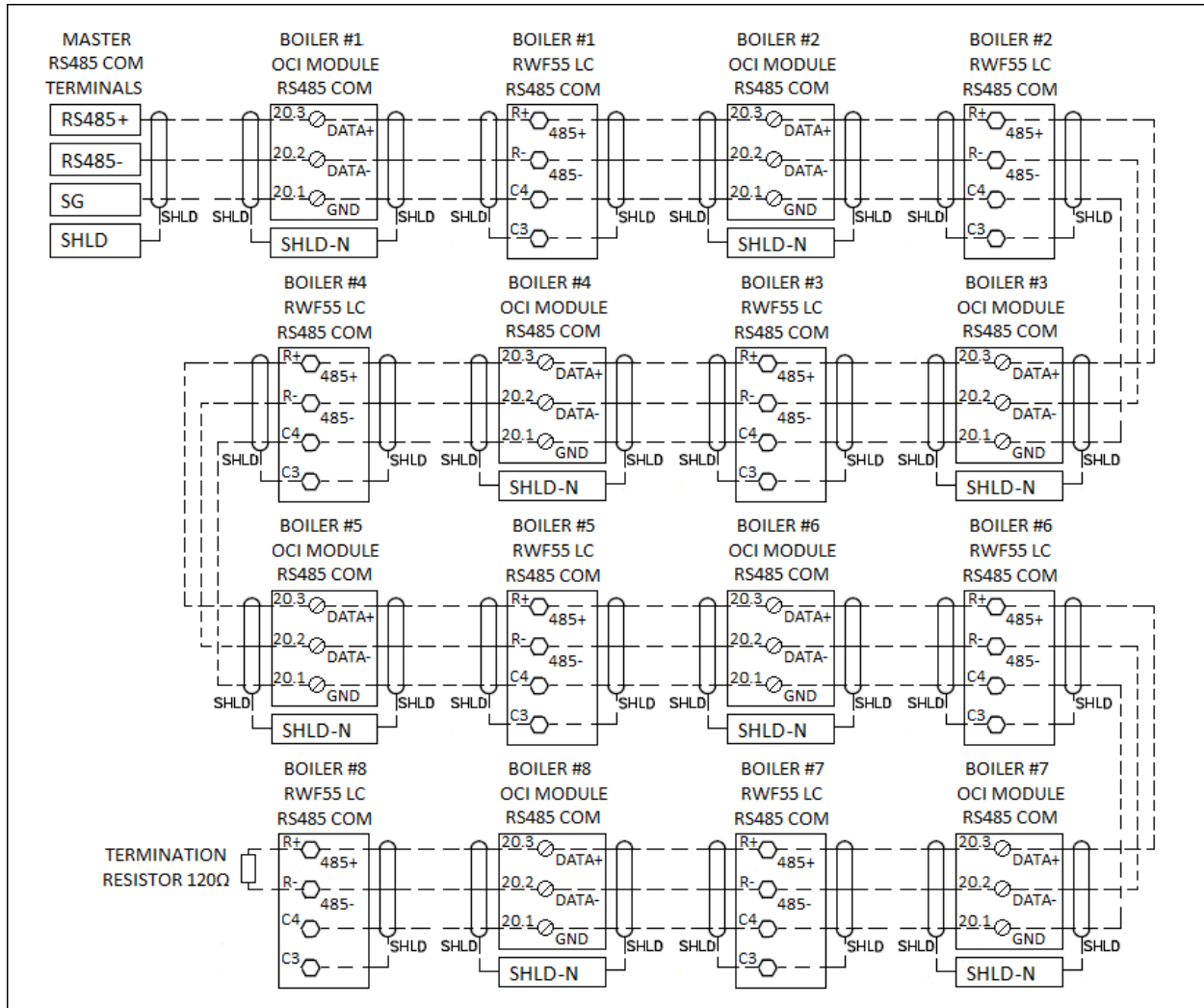

Connections (continued)

Modbus RS-485 serial connection with LMV3x serial kits (no touchscreen at each boiler), and with RWF55 as load controller (LC), and RWF55 as water level controller (WL)

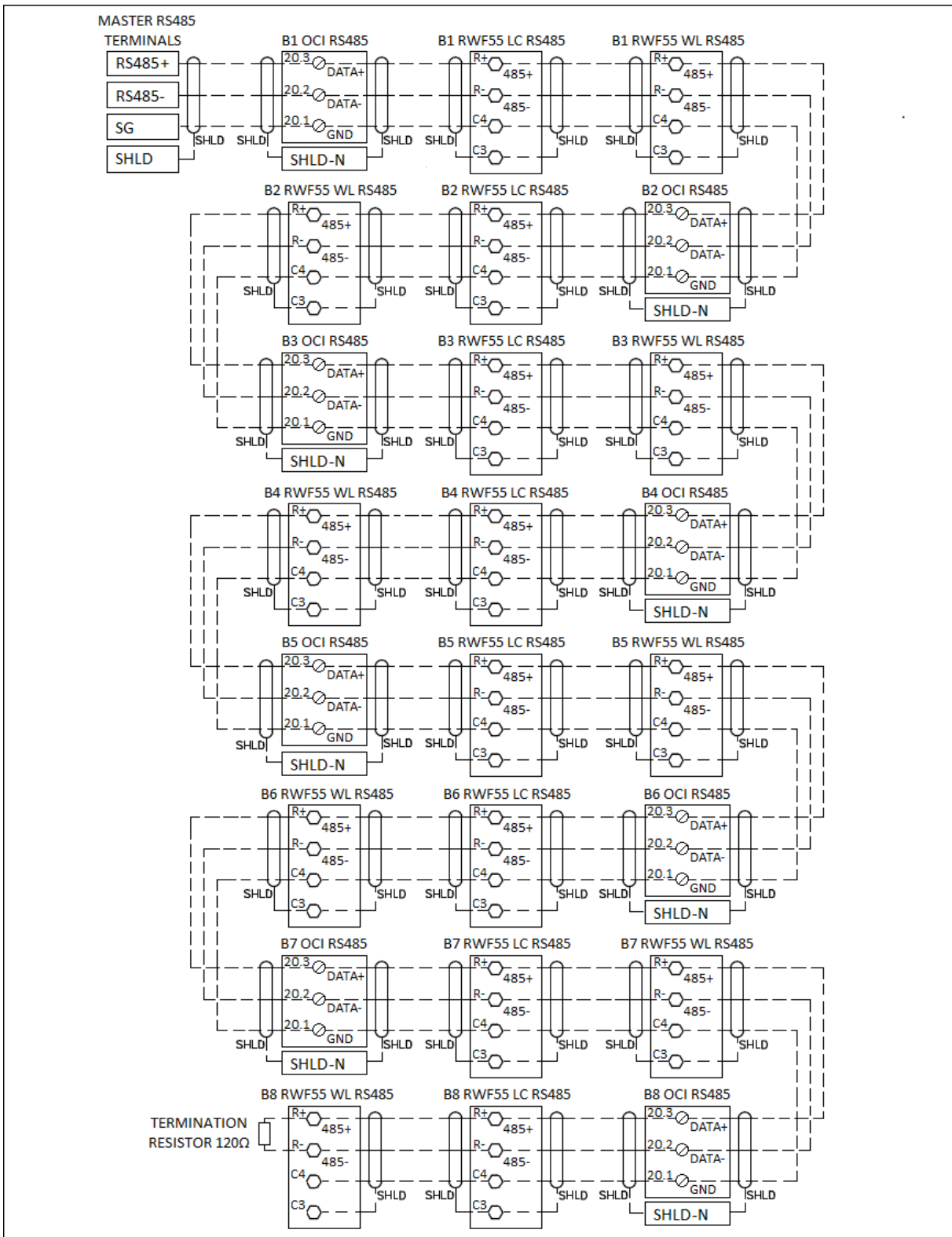

Connections (continued)

Modbus RS-485 serial connection with LMV3x serial kits (no touchscreen at each boiler), RWF10 as load controller (LC)

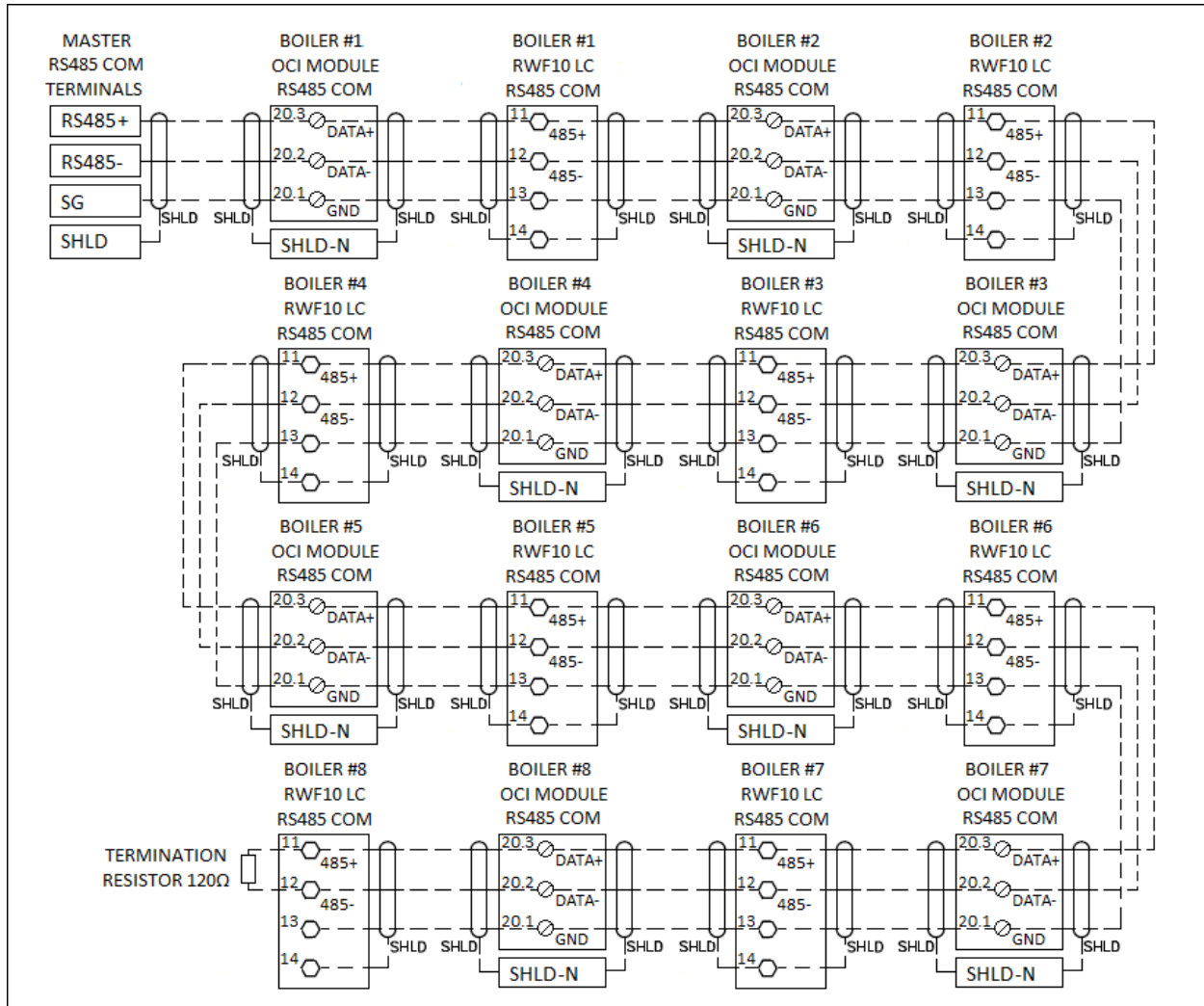

Connections (continued)

Modbus RS-485 serial connection with LMV3x serial kits (no touchscreen at each boiler), RWF10 as load controller (LC), and RWF55 as water level controller (WL)

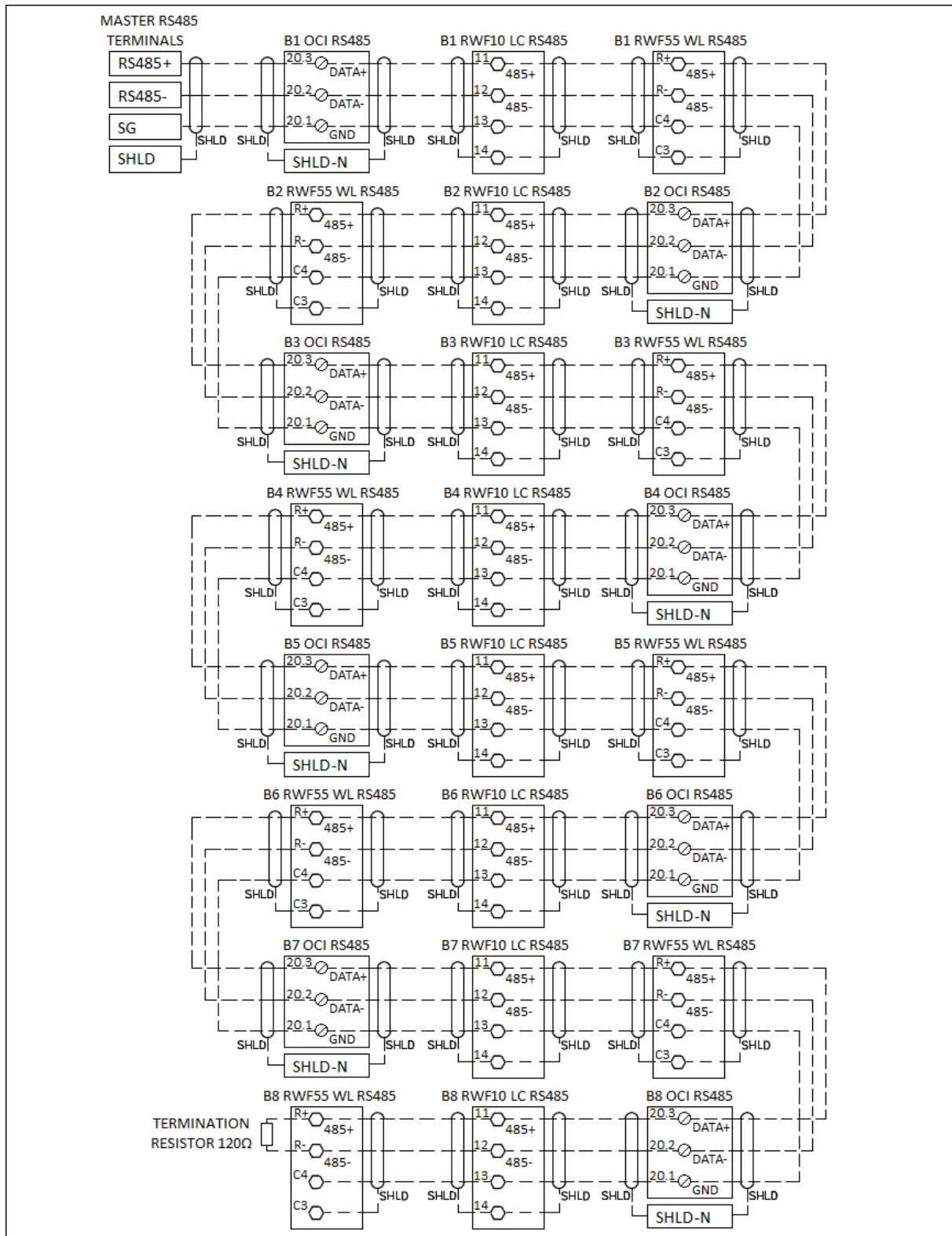

Connections (continued)

Modbus RS-485 serial connection with RWF55 load controller (LC)

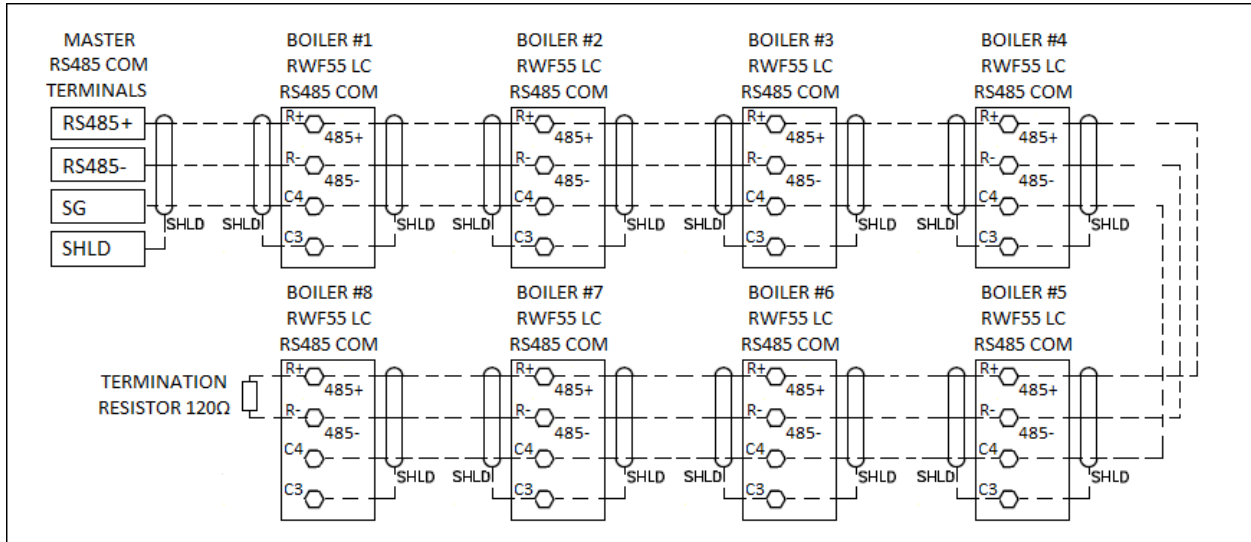

Connections (continued)

BMS Communications Connections

Standard Modbus TCP/IP

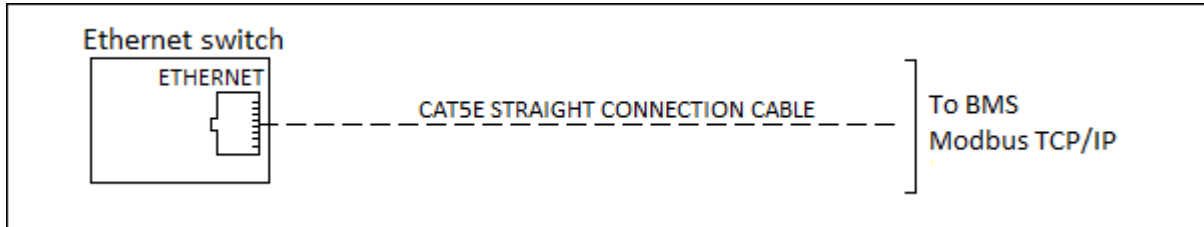

Standard Modbus RTU RS232

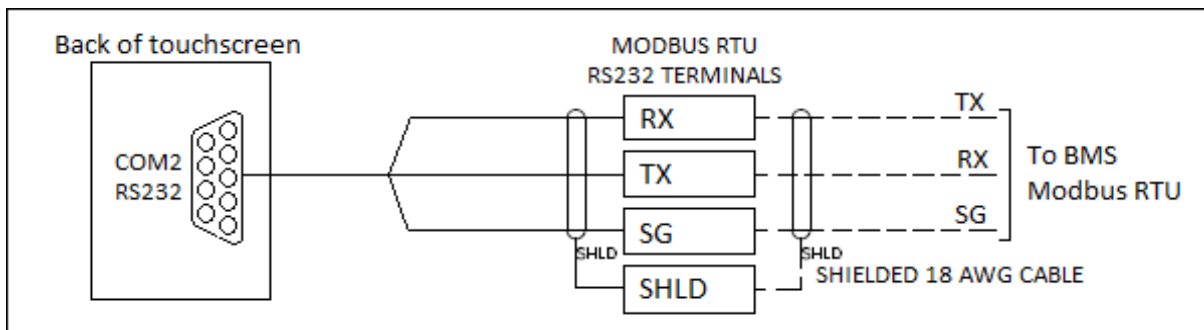

Standard Modbus RTU RS485

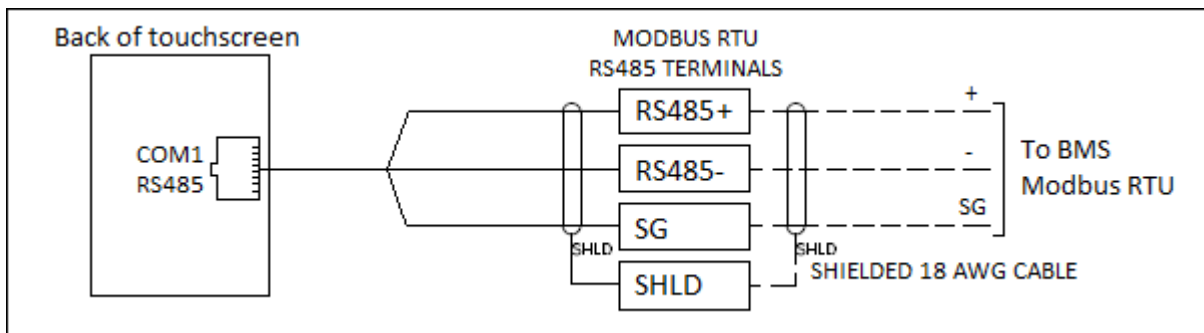

Connections (continued)

BMS Communication Connections

N2 Johnson, BACnet MS/TP, BACnet/IP, or Modbus TCP/IP

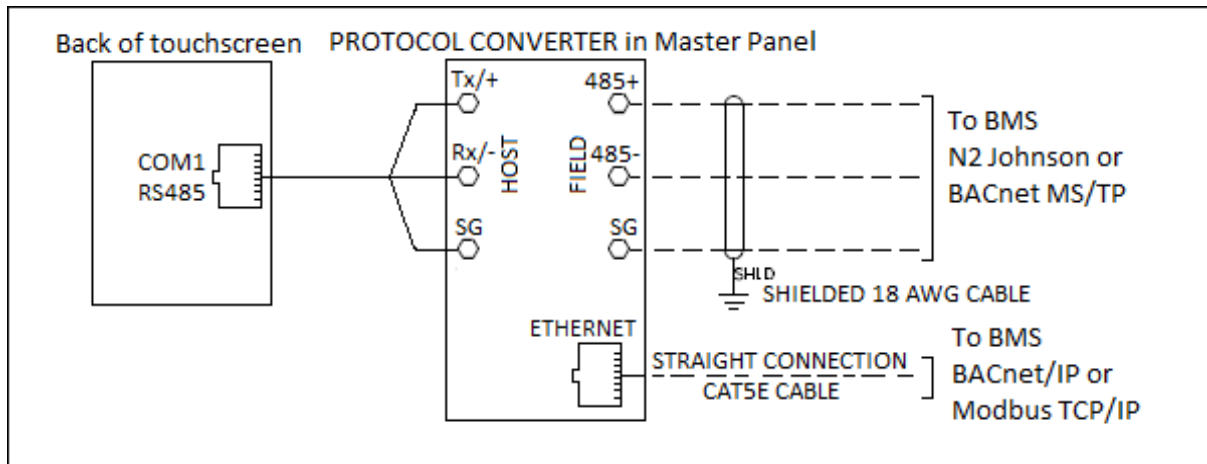

BACnet/IP, EtherNet/IP, or PROFINET (RTA) only with boiler data or Ethernet/IP

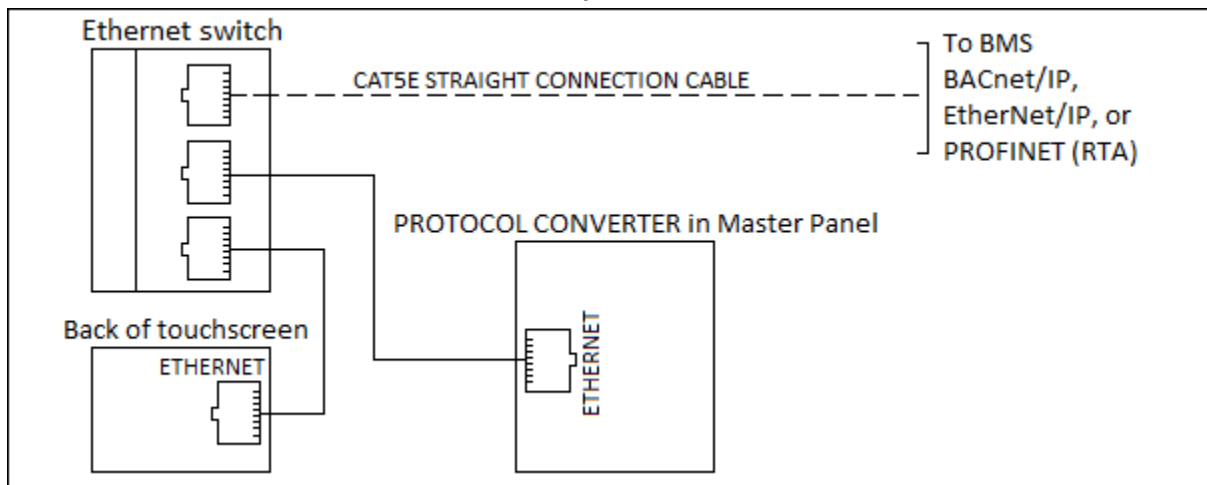

Connections (continued)

BMS Communication Connections

PROFINET or PROFIBUS

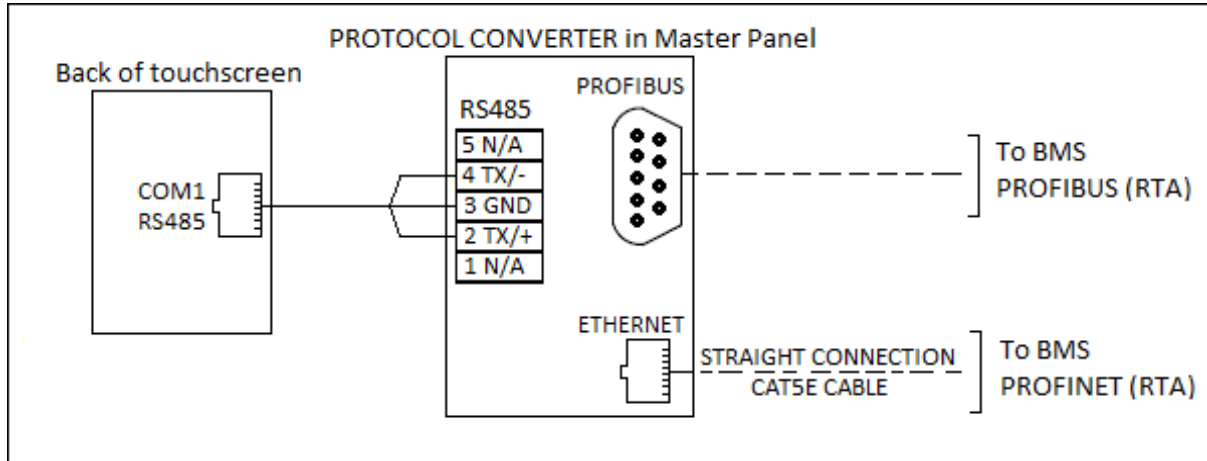

LonWorks

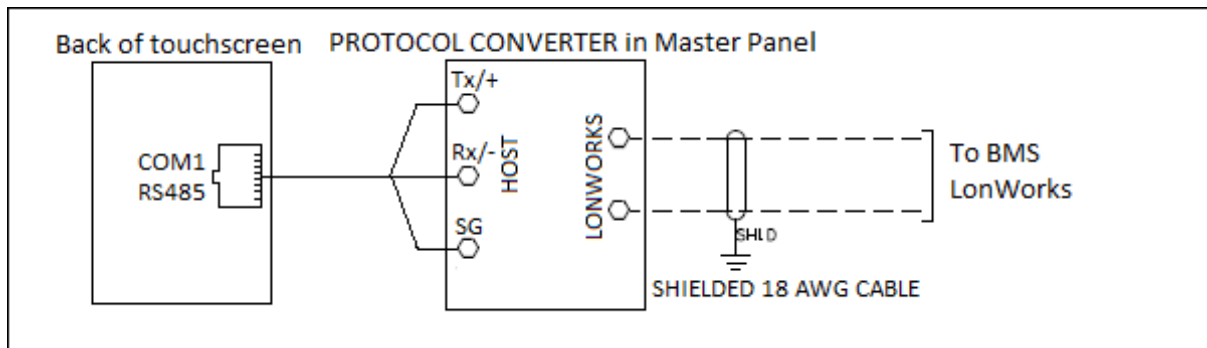

Enclosure Parts Description

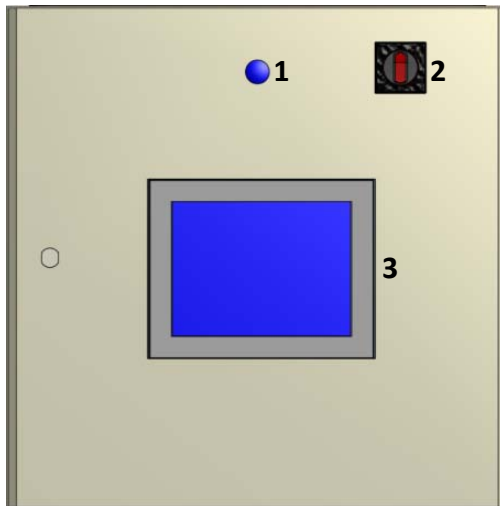

Front

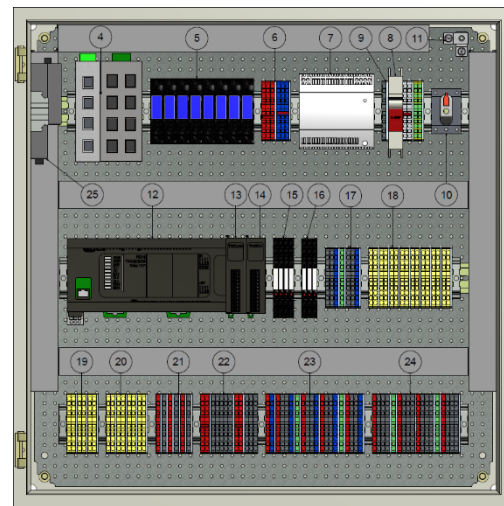

Back Pan

- 1- 24 VDC PLC normal indicator light
- 2- Main 120 VAC lockable disconnect handle
- 3- 7", 10" or 12" Schneider touchscreen
- 4- Ethernet switch, number of ports dependent upon product part number
- 5- Circulating pump and isolation valves output relays, only if circulating pump controls option (Y) is selected for hot water boilers (Application H, W, or Z)
- 6- 24 VDC enclosure terminals
- 7- 24 VDC power supply
- 8- Circuit breaker
- 9- 120 VAC power terminals
- 10- 120 VAC main disconnect with UL lock
- 11- Ground lugs
- 12- Schneider Programmable Logic Controller (PLC)
- 13- Analog input module, standard for (Application S, R, or U); included if analog option (A) is selected for hot water boilers (Application H, W, or Z)
- 14- RTD input module, standard for hot water boilers (Application H, W, or Z); included if RTD option (T) is selected for steam boilers (Application S, R, or U)
- 15- Monitored value discrete output relays
- 16- General and analog high/low alarm relays
- 17- Analog output field terminals
- 18- Circulating pumps control field terminals, standard for hot water boilers only (Application H, W, or Z)
- 19- General, PLC normal, high, and low analog input alarm field terminals
- 20- Monitored value discrete output field terminals
- 21- Override, remote set point, and remote disable field terminals
- 22- Circulating pump proven field terminals for hot water boilers only (Application H, W, or Z)
- 23- RTD input field terminals, standard for hot water boilers (Application H, W, or Z), optional for steam boilers (Application S, R, or U)
- 24- Analog input field terminals, standard for steam boilers (Application S, R, or U), included if analog option (A) is selected for hot water boilers (Application H, W, or Z)
- 25- BMS interface module for communications other than Modbus (Options B, L, or M)

Enclosure Dimensions

Dimensions in inches; millimeters in brackets

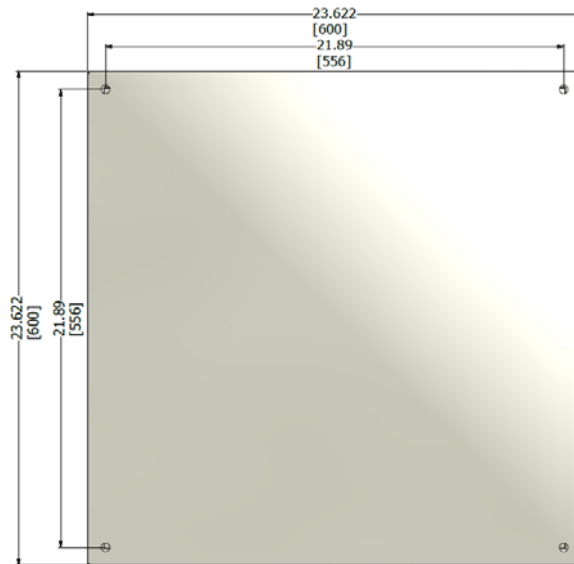

Back

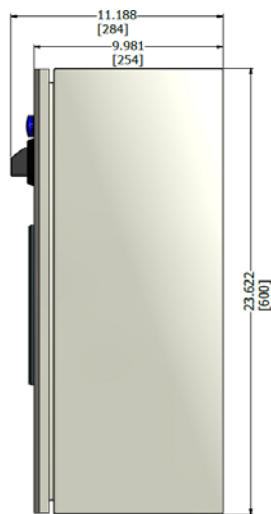

Side (NEMA 1/NEMA 4X)

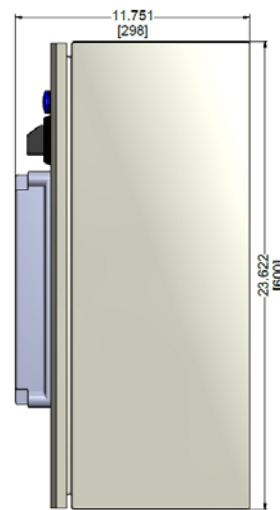

Side (NEMA 12 with cover)

Information in this publication is based on current specifications. The company reserves the right to make changes in specifications and models as design improvements are introduced. Product or company names mentioned herein may be the trademarks of their respective owners. © 2009 SCC Inc.