

## TS Series

---

### TS... Serial Communication Kits for use with LMV3, LMV5, and RWF... Controls

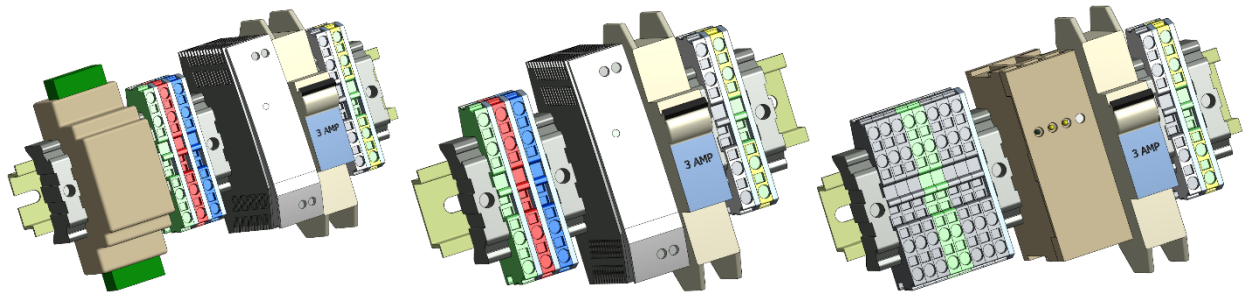

---

### Description

A TS... series serial communication kit connects a Siemens LMV linkageless control system to an SCC Master Lead/Lag Panel without a local touchscreen at each boiler.

The TS... serial kit communicates serially between each LMV linkageless control system and an SCC Master Lead/Lag Panel for up to eight boilers.

---

### Features

- Serial RS485 Modbus interface to SCC Master Lead/Lag Panel
- Daisy chain via shielded cable between serial kits at each burner with LMV controls
- LMV3 or LMV5 serial RS485 communications

---

### Application

TS... serial communication kits are suited for condensing boilers, steam boilers, and other applications utilizing an LMV3 or LMV5 linkageless control system without a local touchscreens at each boiler.

---

### Components

TS... serial communication kits include the following components:

- 3 Amp circuit breaker
- 24 VDC power supply with TS-3X-KT or TS-3M-KT
- RS232 to RS485 converter with TS-5X-KT
- Field interconnecting terminals

## Product Part Numbers

For communication kit part number identification only. See Table 1 for available part numbers.

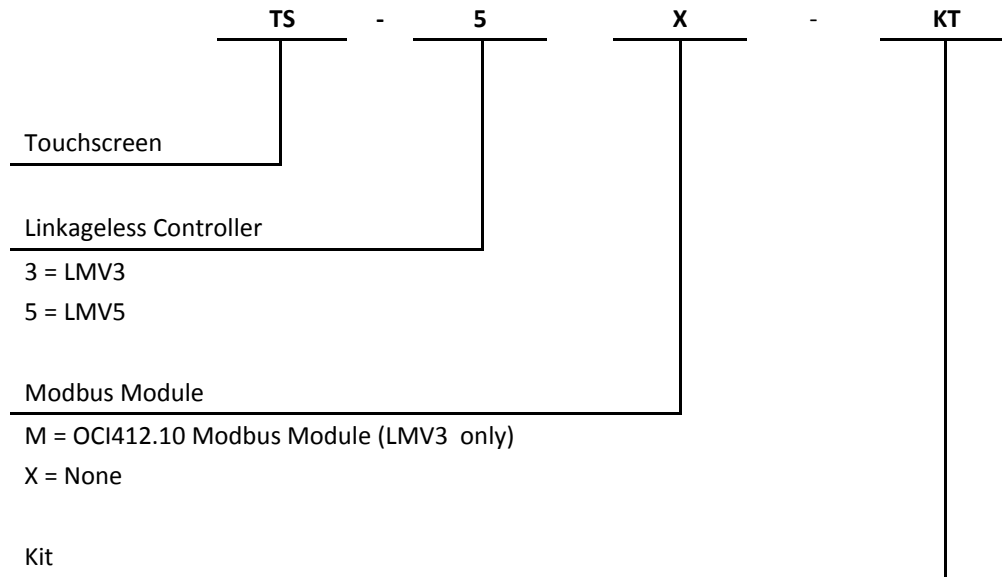

**Table 1: Available Serial Communication Kits**

| Part Number | Connects to Linkageless System |      | Modbus Module LMV3 | 24 VDC Power Supply |
|-------------|--------------------------------|------|--------------------|---------------------|
|             | LMV3                           | LMV5 | OCI412.10          | TS-PS-24VDC2.5A     |
| TS-3X-KT    | x                              |      |                    | x                   |
| TS-3M-KT    | x                              |      | x                  | x                   |
| TS-5X-KT    |                                | x    |                    |                     |

## Specifications

|                            |                             | TS-3X-KT, TS-3M-KT            | TS-5X-KT                        |
|----------------------------|-----------------------------|-------------------------------|---------------------------------|
| Electrical characteristics | Main Operating Voltage      | 120 VAC                       | 120 VAC                         |
|                            | Main Operating Frequency    | 50 – 60 HZ                    | 50 – 60 HZ                      |
|                            | Component Operating Voltage | 24 VDC/VAC                    | 120 VAC                         |
|                            | Power Consumption           | ≤ 60 VA                       | 5 VA max                        |
| Operating environment      | Operating Temperature       | 32 to 122 °F<br>[0 to 50 °C]  | -10 to 131 °F<br>[-16 to 55 °C] |
|                            | Humidity                    | Max. 85% with no condensation | Max. 85% with no condensation   |

## Connections

### TS-3X-KT with LMV3, RWF55 load controller (LC), and RWF55 for water level controller (WL)

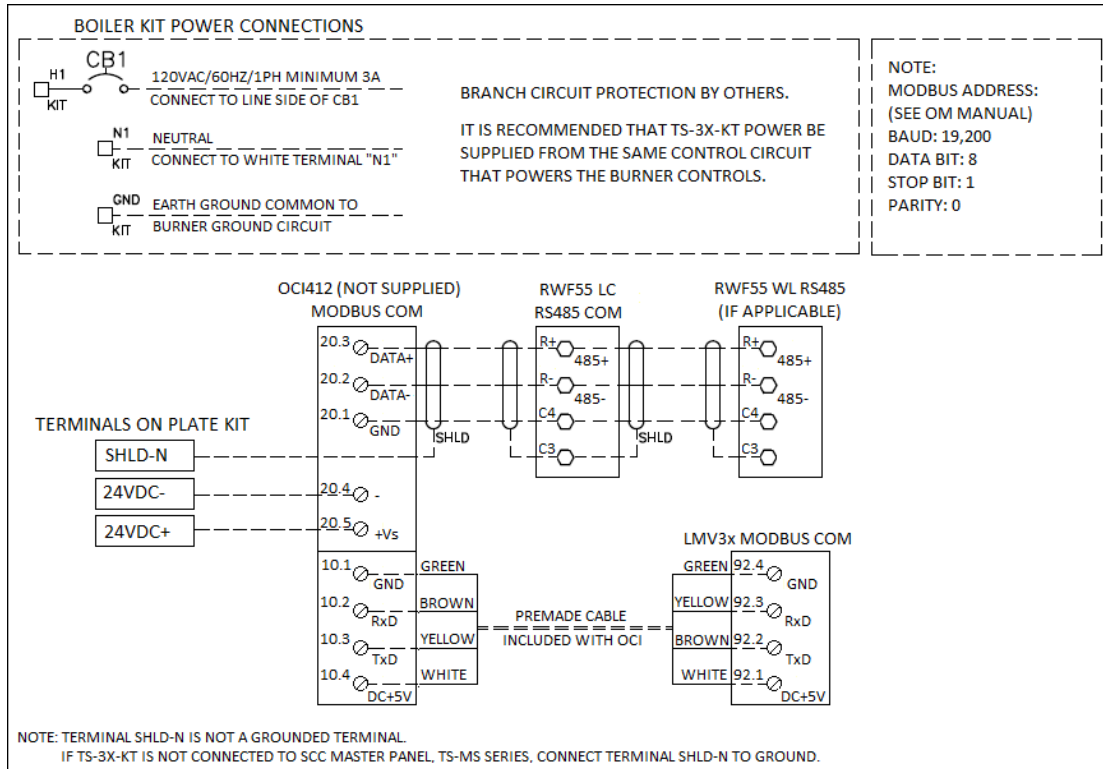

### TS-3X-KT with LMV3, RWF10 load controller (LC), and RWF55 for water level controller (WL)

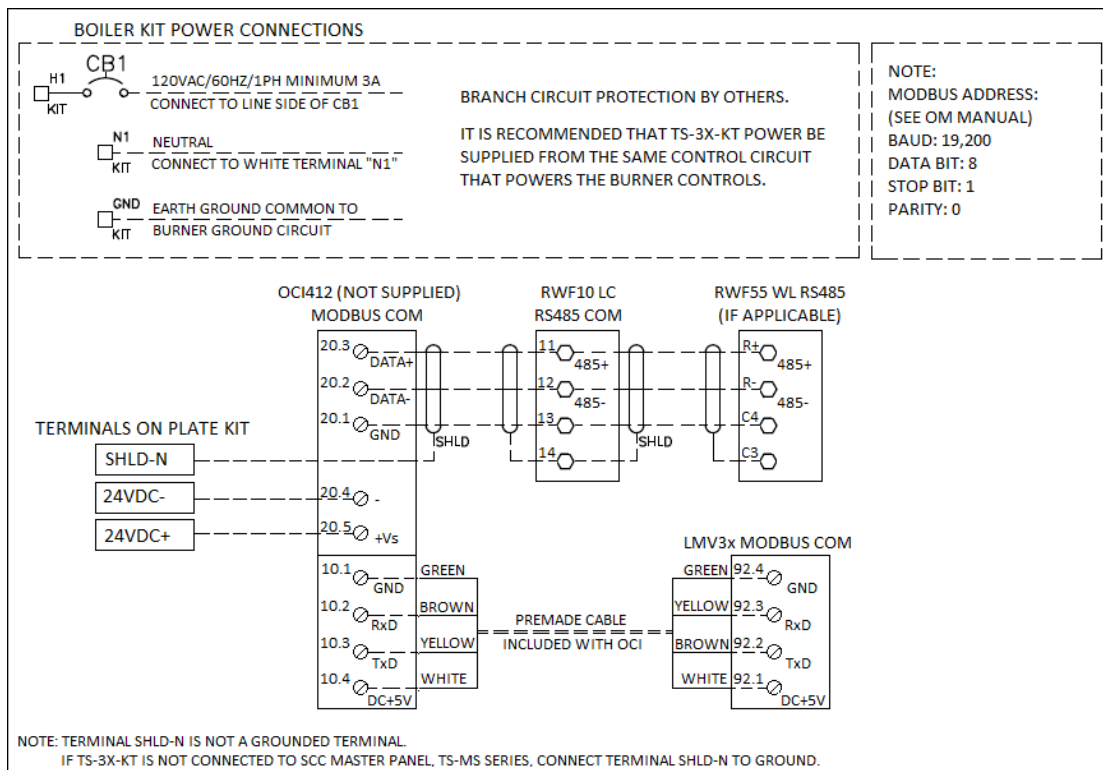

## Connections (continued)

### TS-3M-KT with LMV3, RWF55 load controller (LC), and RWF55 for water level controller (WL)

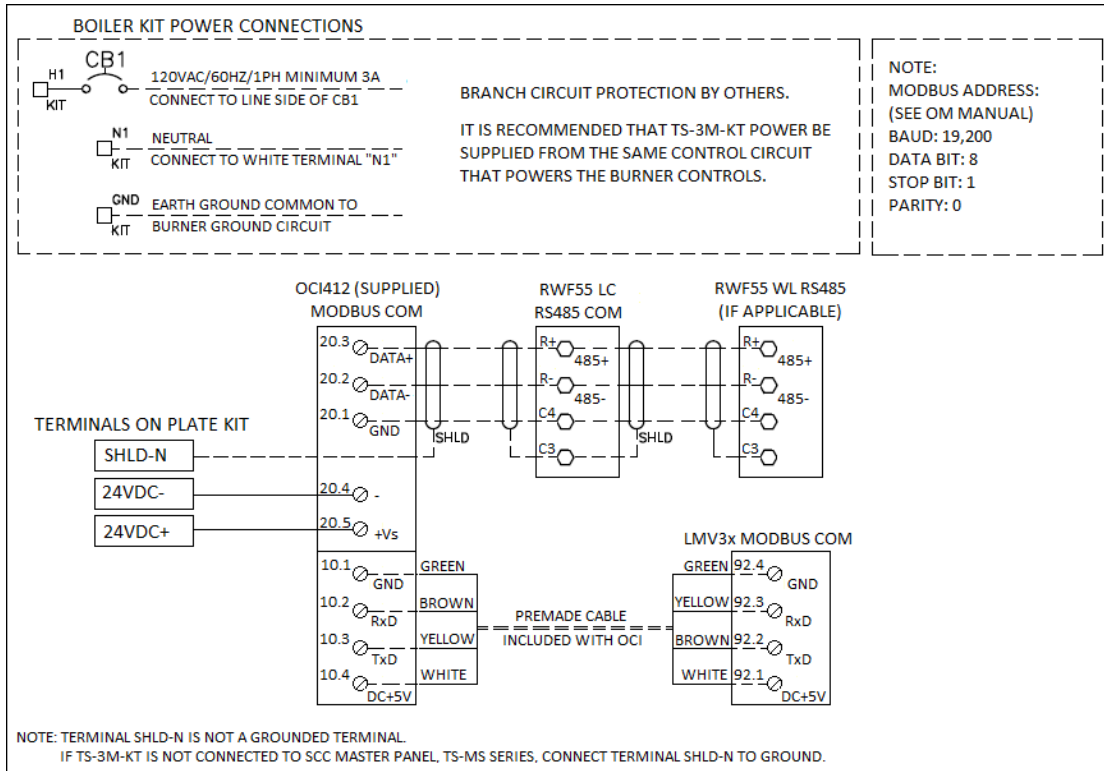

### TS-3M-KT with LMV3, RWF10 load controller (LC), and RWF55 for water level controller (WL)

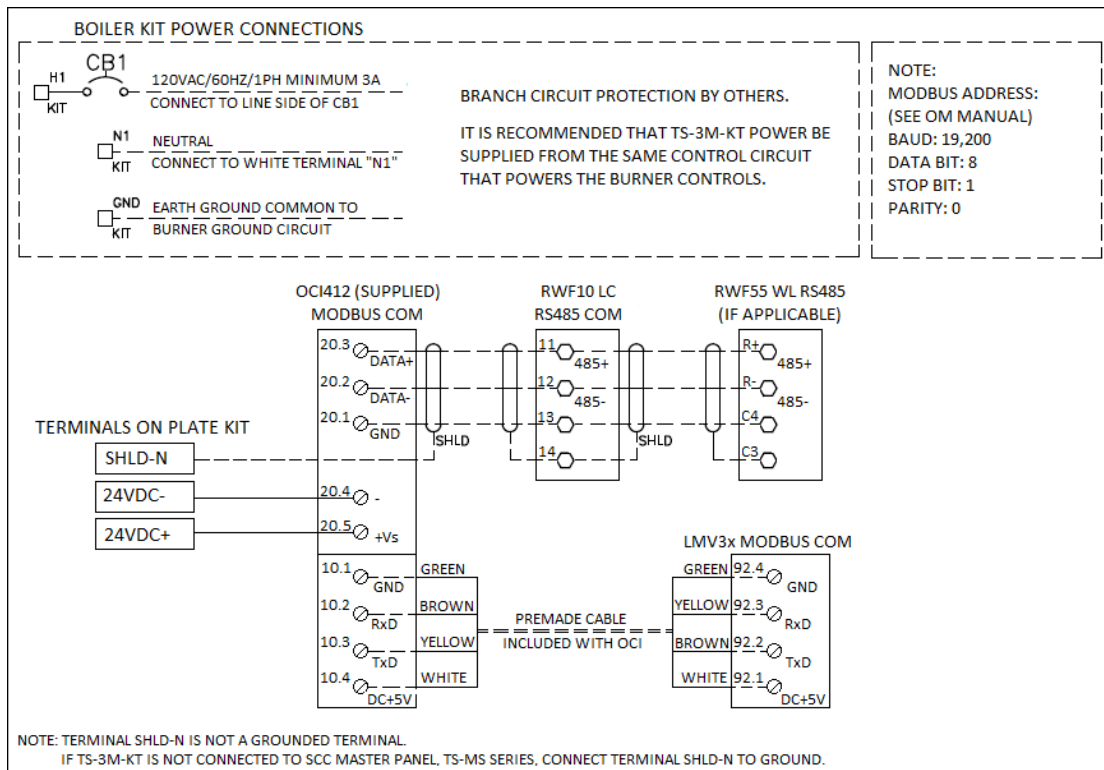

## Connections (continued)

### TS-5X-KT with LMV5, RWF55 load controller (LC), and RWF55 for water level controller (WL)

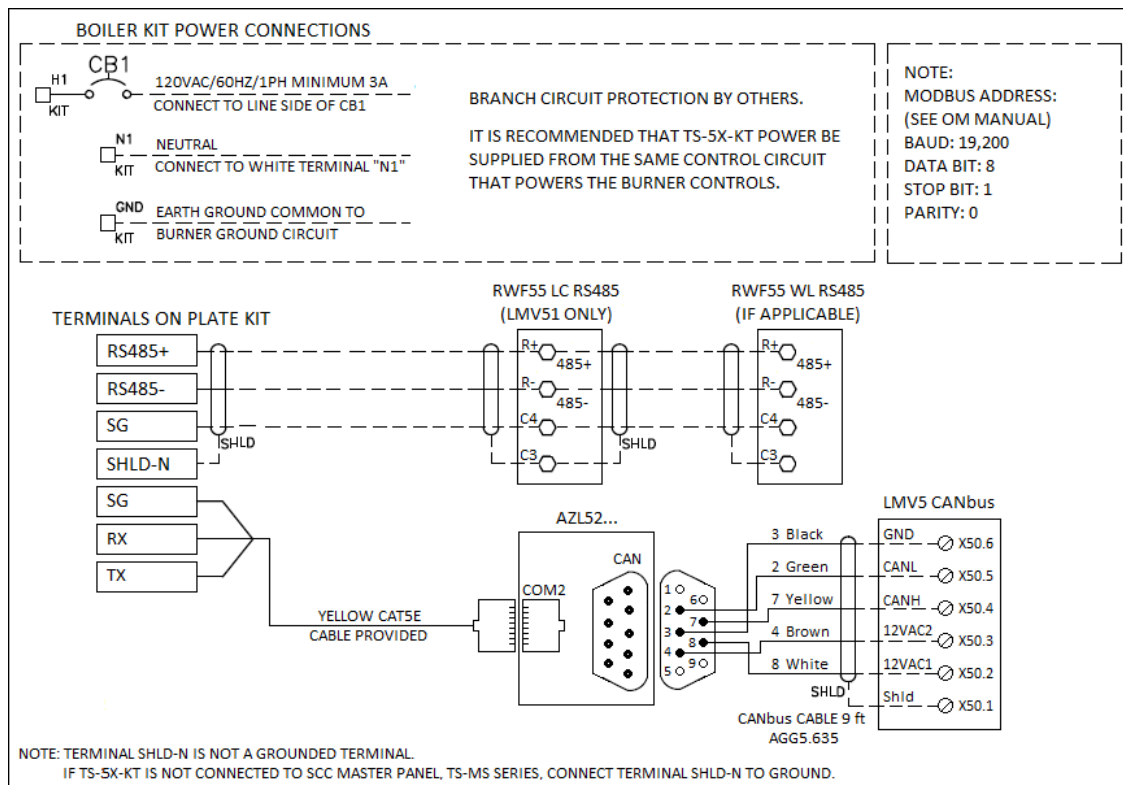

**Note:** For all RS-485 connections, use Belden Cable 3106A (multi-conductor cable with twisted pair, EIA Industrial RS-485 PLTC/COM) or equivalent.

**Table 2: Belden Cable 3106A Wire Color Designation**

| Electrical Diagram | Belden Cable 3106A |
|--------------------|--------------------|
| Red (RS485+)       | Orange (RS485+)    |
| Black (RS485-)     | White (RS485-)     |
| White (SG)         | Blue (SG)          |

## Parts Description

### TS-3X-KT

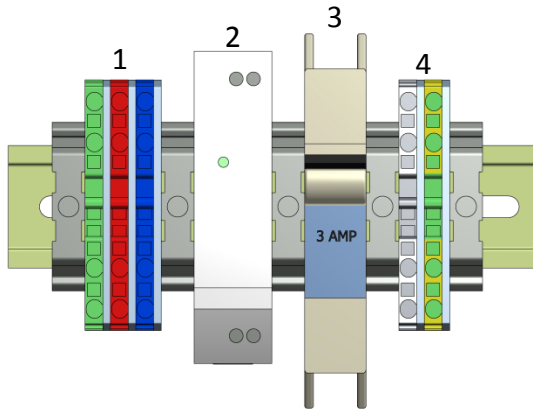

- 1- 24 VDC Terminals
- 2- 24 VDC Power Supply
- 3- 3 Amp Circuit Breaker
- 4- Neutral and Ground Power Terminals

### TS-3M-KT

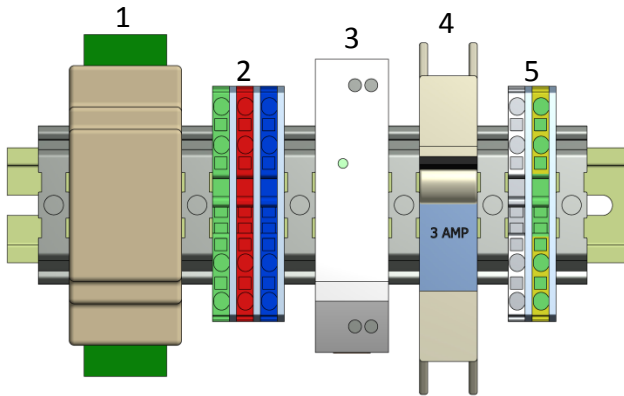

- 1- OCI Modbus RS485 Module
- 2- 24 VDC Terminals
- 3- 24 VDC Power Supply
- 4- 3 Amp Circuit Breaker
- 5- Neutral and Ground Power Terminals

### TS-5X-KT

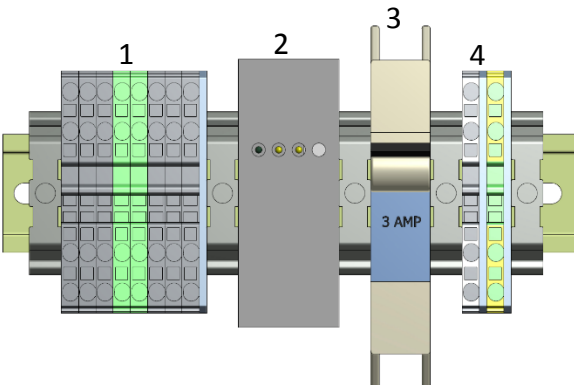

- 1- RS232-RS485 Modbus Interconnecting Terminals
- 2- Modbus Communication Module
- 3- 3 Amp Circuit Breaker
- 4- Neutral and Ground Power Terminals

## Dimensions

Dimensions in inches; millimeters in brackets

### TS-3X-KT

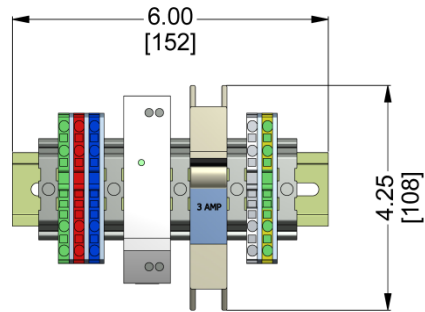

### TS-3M-KT

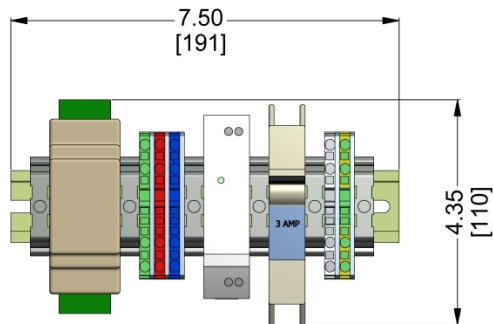

### TS-5X-KT

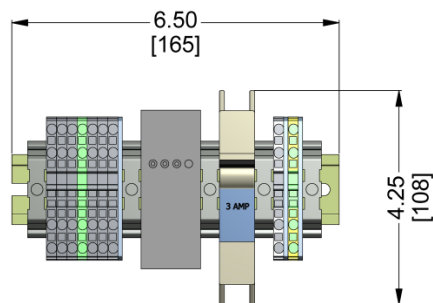

Information in this publication is based on current specifications. The company reserves the right to make changes in specifications and models as design improvements are introduced. Product or company names mentioned herein may be the trademarks of their respective owners. © 2009 SCC Inc.