



Presentation example PME7...

Presentation example LME7...

## PME73.811... Program module for burner control LME73.000

### User Documentation

#### Application:

- stage or modulating, direct or pilot ignited forced draft burners
- Integrated actuator control via 3-position controller or analog signal (feedback potentiometer in the actuator required)
- Integrated valve proving (can be parameterized)
- Actuator without CLOSED position, ignition load = low-fire position
- Response time in case of loss of flame 3 seconds (1 second / 3 seconds adjustable)
- E.g. for burners to EN 676 or industrial thermo process plants to EN 746 part 2

The PME7... and this User Documentation are intended for use by OEMs which integrate the LME7... with PME7... in their products.



**Note!**  
This documentation is only valid together with LME7... Basic Documentation (P7105)!

# Contents

1	Supplementary documentation .....	3
2	Warning notes .....	4
3	Typographical conventions .....	4
4	Program sequence PME73.811.....	5
5	List of phase display .....	7
6	Fuel trains (examples) .....	9
6.1	Gas direct ignition (G), 1-stage .....	9
6.2	Gas pilot ignition 1 (Gp1/1), 1-stage .....	9
6.3	Gas pilot ignition 1 (Gp1/2), 1-stage, with valve proving.....	10
7	Valve proving .....	11
8	Input POC .....	13
9	Input gas pressure switch-min .....	13
10	Shutdown sequence (parameter 212) .....	13
11	Connection diagram for LME72.000... with actuator SQM4... .....	14
12	Time table and settings .....	15
13	Inputs and outputs / internal connection diagram .....	17
14	Parameter list (AZL2... ).....	18
15	Error code list.....	21
16	Legend .....	22
17	List of figures .....	23

# 1 Supplementary documentation

Product type	Type of documentation	Documentation number
LME...	Environmental Product Declaration	E7105
PME...	Environmental Product Declaration	E7105.1
LME7...	Data Sheet	N7105
LME7	Basic Documentation	P7105
LME...	Product Range Overview	Q7101

## 2 Warning notes



### Warning!

The safety, warning and technical notes given in the Basic Documentation on the LME7... (P7105) apply fully to the present document also!

To avoid injury to persons, damage to property or the environment, the following warning notes must be observed!

The LME7... are safety devices! Do not open, interfere with or modify the unit. Siemens does not assume responsibility for damage resulting from unauthorized interference!

## 3 Typographical conventions

### Safety notes

This User Documentation contains notes which must be observed to ensure your personal safety and to protect the product and the connected equipment. The instructions and notes are highlighted by warning triangles or a hand symbol and are presented as follows, depending on the hazard level:



#### Warning

means that death, severe personal injury or substantial damage to property **can** occur if adequate precautionary measures are not taken



#### Note

draws your attention to **important information** on the product, on product handling, or to a special part of the documentation

### Qualified personnel

Only **qualified staff** are allowed to install and operate the equipment. Qualified staff in the context of the safety-related notes contained in this document are persons who are authorized to commission, ground and tag devices, systems and electrical circuits in compliance with established safety practices and standards.

### Correct use

*Note the following:*

The device may only be used on the applications described in the technical documentation and only in connection with devices or components from other suppliers that have been approved or recommended by Siemens.

The product can only function correctly and safely if shipped, stored, set up and installed correctly, and operated and maintained as specified.

# 4 Program sequence PME73.811...

→ For fuel trains **G** and **Gp1** without or with valve proving



**Caution!**  
**Factory setting:**  
**Parameter 254 → Flame-out response time in case of loss of flame 3 seconds!**  
**For a flame-out response time about 1 second, the parameter 254 must be changed.**

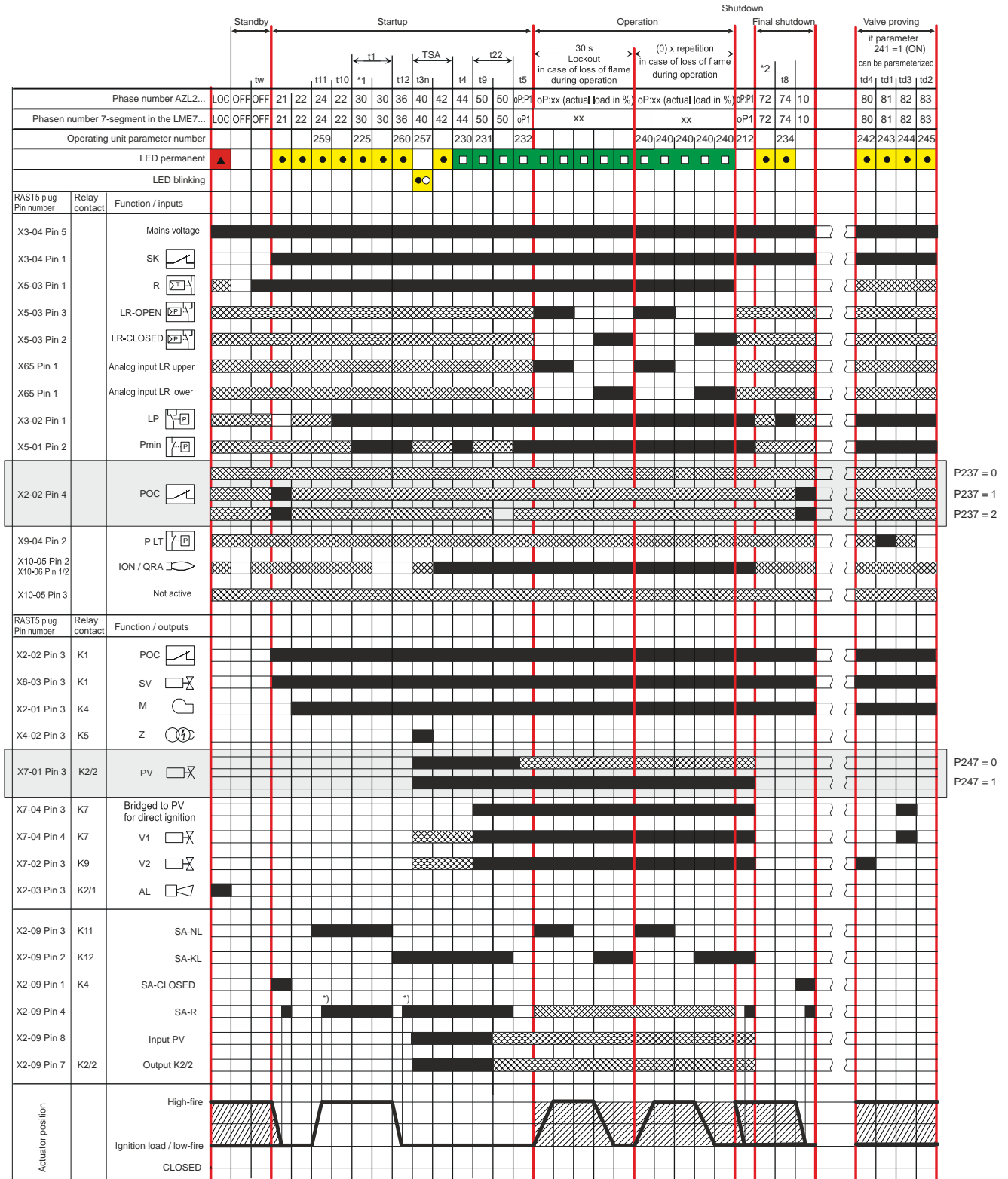

Figure 1: Program sequence **G** and **Gp1**

7105d91e/0218

Program sequence modulating with SQM4x.x1... / SQM4x.x2... / SQM4x.x4... / SQM4x.x5...

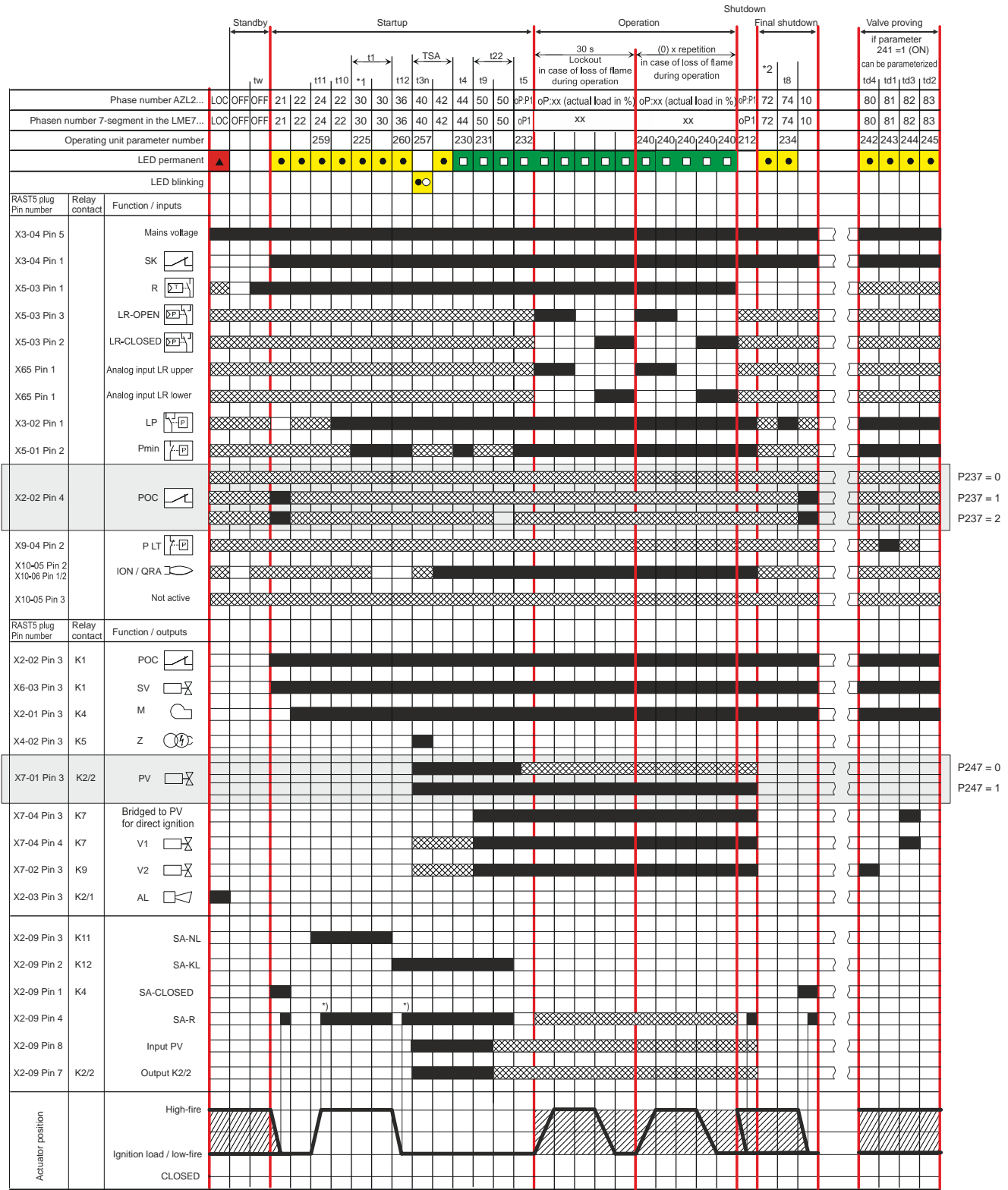

Figure 2: Program sequence with SQM4

- \* ) During the actuator's running phases, the actuator's feedback signal must first be OFF, then ON
- \*1 Valve proving during prepurging, if
  - parameter 241 = 1 after power ON, lockout or
  - parameter 234 (postpurge time) = 0 seconds
- \*2 Valve proving during postpurging, if
  - parameter 241 = 1 and
  - parameter 234 (postpurge time) >0 seconds

## 5 List of phase display

Phase number of display		LED	Function
7-segment	AZL2...		
LOC	LOC	OFF	Lockout phase
<b>Standby</b>			
OFF	OFF	OFF	Standby, waiting for heat request
P08	Ph08	OFF	Power ON/test phase (e.g. detector test)
<b>Startup</b>			
P21	Ph21	Yellow	Safety valve ON, air pressure switch in no-load position Test if POC closed (timeout/lockout after 5 seconds) Actuator travels in CLOSED position (timeout)
P22	Ph22	Yellow	Part 1: Fan motor ON Part 2: Specified time air pressure switch Message (timeout), stabilization air pressure switch
P24	Ph24	Yellow	Actuator travels in prepurge position (timeout)
P30	Ph30	Yellow	Part 1: Prepurge time without extraneous light test *1 Part 2: Prepurging with extraneous light test (2.1 seconds)
P36	Ph36	Yellow	Actuator travels in ignition load position (timeout)
P40	Ph40	Yellow flashing	Postignition time
P42	Ph42	Green	Flame detection
P44	Ph44	Green	Interval: End of safety time and fuel valve V1 and fuel valve V2 ON
P50	Ph50	Green	Part 1: Interval: Fuel valve V1 or fuel valve V2 ON and pilot valve OFF Part 2: Flame-out response time
<b>Operation</b>			
xx	oP:xx	Green	Operation (modulation), display of actual load in percent (%)
oP1	oP:P1	Green	Part 1: Interval until load controller release Part 2: Exit operation (shutdown): The actuator travels toward low-fire position CLOSED while it is running (parameter 212)
<b>Shutdown</b>			
P10	Ph10	OFF	Home run
P72	Ph72	Yellow	Shutdown, valve proving *2
P74	Ph74	Yellow	Postpurge time
<b>Valve proving</b>			
P80	Ph80	Yellow	Test space is evacuated
P81	Ph81	Yellow	Test time atmospheric pressure
P82	Ph82	Yellow	Test space is filled
P83	Ph83	Yellow	Test time gas pressure
<b>Safety shutdown phases</b>			
P01	Ph01	Yellow / red	Under voltage / over voltage
P02	Ph02	Yellow	Safety shutdown (e.g. open safety loop) → lockout
P04	Ph04	Green / red	Extraneous light in standby
P90	Ph90	Yellow	Gas pressure switch-min open → lockout

*1	Valve proving during prepurging, if - parameter 241 = 1 after power ON, lockout or - parameter 234 (postpurge time) = 0 seconds
*2	Valve proving during postpurging, if - parameter 241 = 1 and - parameter 234 (postpurge time) >0 seconds



# 6 Fuel trains (examples)

## 6.1 Gas direct ignition (G), 1-stage

**LME73.000...**

X7-01			X7-04			
1	2	3	1	2	3	4
PE	N	L	PE	N	L	L
Dbr2			V1			

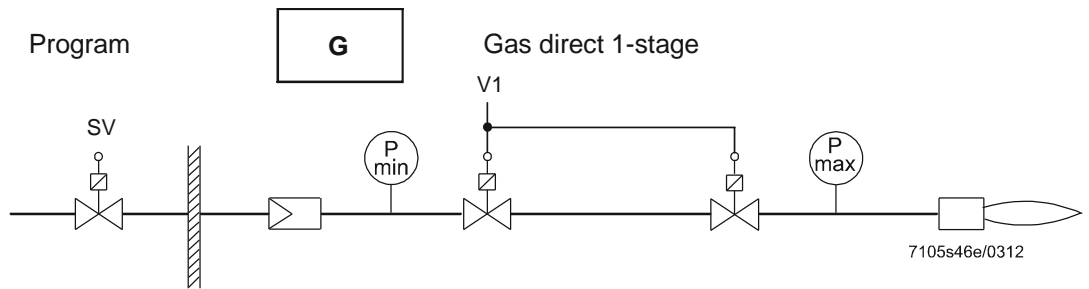

**LME73.000...**

X2-09

1	2	3	4	5	6	7	8
SA-CLOSE	SA-KL	SA-NL	SA-R	PE	N	Output K2/2	Input PV
							Dbr3

Figure 3: Fuel train gas direct ignition (G), 1-stage

## 6.2 Gas pilot ignition 1 (Gp1/1), 1-stage

**LME73.000...**

X7-01			X7-04			
1	2	3	1	2	3	4
PE	N	L	PE	N	L	L
PV			V1			

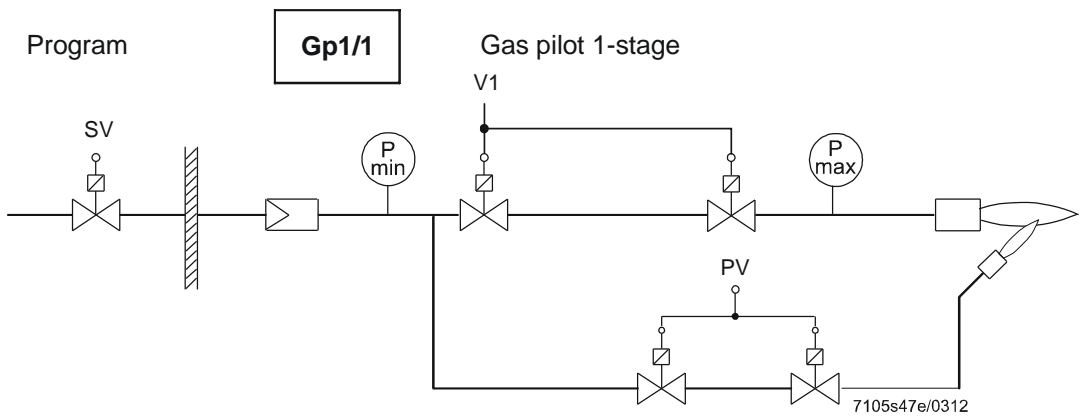

**LME73.000...**

X2-09

1	2	3	4	5	6	7	8
SA-CLOSE	SA-KL	SA-NL	SA-R	PE	N	Output K2/2	Input PV
							Dbr3

Figure 4: Fuel train gas pilot ignition 1 (Gp1/1), 1-stage

## 6.3 Gas pilot ignition 1 (Gp1/2), 1-stage, with valve proving

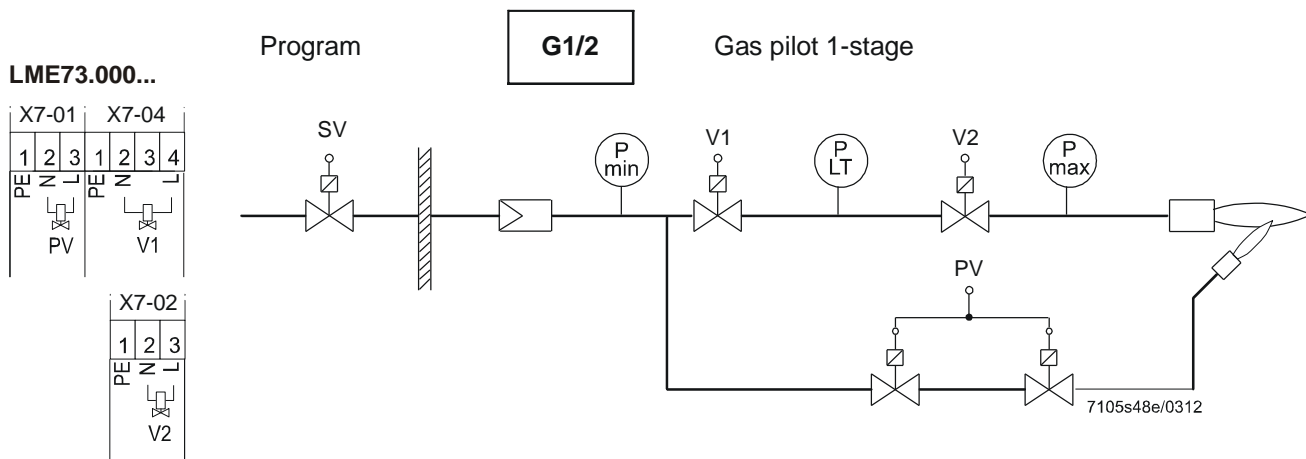

Figure 5: Fuel train gas pilot ignition 1 (Gp1/2), 1-stage, with valve proving



### Note:

When valve proving is activated the load on the valve's terminals is restricted.

Fuel valve V1 terminal X7-04 pin 4 or fuel valve V2 terminal X7-02 pin 3

- Rated voltage AC 120 V AC 230 V
- Rated current 50/60 Hz 50/60 Hz
- Rated current 1 A 1 A
- Power factor  $\cos\varphi > 0.4$   $\cos\varphi > 0.4$

If the terminal load is not reduced (max. rated current 2 A,  $\cos\varphi > 0.4$ ), the design lifetime will be reached after about 100,000 burner startup cycles!

# 7 Valve proving

Valve proving is dependent on parameter 241. It is employed to detect leaking gas valves and, if necessary, to prevent the valves from opening or ignition from being switched on. Lockout is initiated.

## Valve proving with separate pressure switch

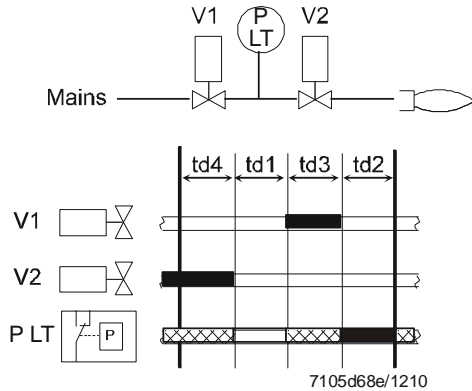

Figure 6: Valve proving with separate pressure switch

Step 1: td4 – test space evacuating.

Gas valve on the burner side is opened to bring the test space to atmospheric pressure.

Step 2: td1 – test time atmospheric pressure.

When the gas valve has closed, the gas pressure in the test space must not exceed a certain level.



Step 3: td3 – test space filling.

Gas valve on the mains side opens to fill the test space.

Step 4: td2 – test time gas pressure.

When the gas valve has closed, the gas pressure in the test space must not drop below a certain level.

### Legend

- td1 Test time atmospheric pressure
- td2 Test time gas pressure
- td3 Test space filling
- td4 Test space evacuating
- V... Fuel valve
- P LT Pressure switch valve proving
-  Input/output signal 1 (ON)
-  Input/output signal 0 (OFF)
-  Permissible input signal 1 (ON) or 0 (OFF)

### Test time atmospheric pressure

- Gas pressure present → pressure switch open
- Gas pressure not present → pressure switch closed

Valve proving can be parameterized to take place on shutdown.

No.	Parameter
241.00	Valve proving 0 = OFF 1 = ON <sup>1)</sup>
242	Valve proving - test space evacuating
243	Valve proving - test time atmospheric pressure
244	Valve proving - test space filling
245	Valve proving - test time gas pressure

<sup>1)</sup> Valve proving during postpurging, if parameter 234 >0 (postpurge time) and parameter 241 = 1

## Program sequence with valve proving

During startup Valve proving during startup is performed only after resetting from the lockout position, after Power ON, and when parameter 234 = 0 seconds.

In that case, valve proving takes place at the same time as pre-purging. This means that the pre-purge time corresponds to at least the sum of all 4 valve proving parameters (242, 243, 244, and 245).

During shutdown Valve proving during shutdown is performed only if the post-purge time is greater than 0 seconds (parameter 234 > 0).

If no postpurge time is parameterized, valve proving takes place during startup when prepurging.

During shutdown (heat request OFF), it is checked if parameter 241 = 1 second (valve proving ON) and parameter 234 ≠ 0 seconds before the fuel valve closes.

This means that, first, fuel valve V1 is closed. Fuel valve V2 remains open, so that the remaining gas in the test space can be burned. The postpurge time runs at the same time as valve proving.

This means that the post-purge time corresponds to at least the sum of all 4 valve proving parameters (242, 243, 244, and 245).

During postpurging and valve proving, the actuator remains in the position reached during its running time (parameter 212).



### Warning!

**The OEM must set the evacuation, filling and test times for atmospheric or mains pressure on every plant in compliance with the requirements of EN 1643. If not observed, there is a risk of impairment of safety functions.**

It must be ensured that the 2 test times are correctly set. It is to be checked whether the gas required for the test may be fed into the combustion chamber (on the relevant application). The test times are safety-related.

After a reset, unlock, and in the case of aborted or prevented valve proving, the LME7 will perform valve proving the next time it is started up (only when valve proving is activated).

In the case of valve proving, prepurging is active during the startup phase, even if it has been deactivated.

Example of aborted valve proving:

When the safety loop or the start prevention input for gas (containing pressure switch-min) opens during valve proving.

## Valve proving – calculation of leakage rate

$$t_{\text{Test}} = \frac{(P_G - P_W) \cdot V \cdot 3600}{P_{\text{atm}} \cdot Q_{\text{Leak}}}$$

QLeak	in l/h	Leakage rate in liters per hour
PG	in mbar	<b>Overpressure</b> between the fuel valves at the beginning of the test phase
PW	in mbar	Overpressure set on the pressure switch (normally 50% of the gas inlet pressure)
Patm	in mbar	<b>Absolute air pressure</b> (1013 mbar normal pressure)
V	in l	Volume between the fuel valves (test volume) including fuel valve volume of the pilot valve and volume of the pilot path
tTest	in s	Test time

## 8 Input POC

Behavior POC input (terminal X2-02 Pin 3 and Pin 4) Parameter 237 defines if and how the POC is tested.

No.	Parameter
237	POC function 0: Inactive → Input does not need to be connected 1: Active (test during startup and shutdown (not safety relevant)) → POC is checked for closed during startup and shutdown. This means that the POC can be replaced with a wire link. 2: Active (test during startup and shutdown, as well as when switching to operating mode (safety relevant)) → POC is checked for closed during startup and shutdown and checked for open when switching to operating mode. This means that a signal change must take place by switching the POC.

An incorrect signal from the POC (parameter 237 > 0) is detected in the relevant phases. An error-induced lockout takes place (error code Loc; 14).

Factory setting of parameter 237 = 1 second.

This means the POC is active and can be replaced with a wire link.

**Access level: SO**

## 9 Input gas pressure switch-min

Behavior when gas pressure switch-min opens (terminal X5-01 pin 2 and pin 3)

If the minimum gas pressure is not reached (opening of the gas pressure switch-min), the LME7 moves to the lockout position (fault code Loc: 20). If the gas pressure switch-min is closed again following reset, the LME7 carries out a restart (if the heat request is still in place). If the gas pressure switch-min is still open following reset, the LME7 is locked again.

The minimum gas pressure is tested after the pre-purge time, in the interval time, and during operation. The gas pressure switch-min is not evaluated during the first and second safety time.

## 10 Shutdown sequence (parameter 212)

If the heat request at terminal X5-03 pin 1 is deactivated, the actuator closes by traveling toward the low-fire position for the parameterized running time (parameter 212). At the end of the running time (parameter 212) or when the actuator reaches the low-fire position, the closing action and burner operation are ended. The burner is shut down in the actuator position reached.

Upon shutdown, postpurging and/or valve proving take place, depending on the parameter settings made. If parameter 212 = 0, the burner is shut down in the actuator's last running position before the heat request is deactivated.

# 11 Connection diagram for LME72.000... with actuator SQM4...



Note:

The connection diagram shown is merely an example which must be verified in the individual case depending on the application!

**PME73.811... 1-stage modulating**  
**With or without pilot ignition**  
**With or without valve proving**

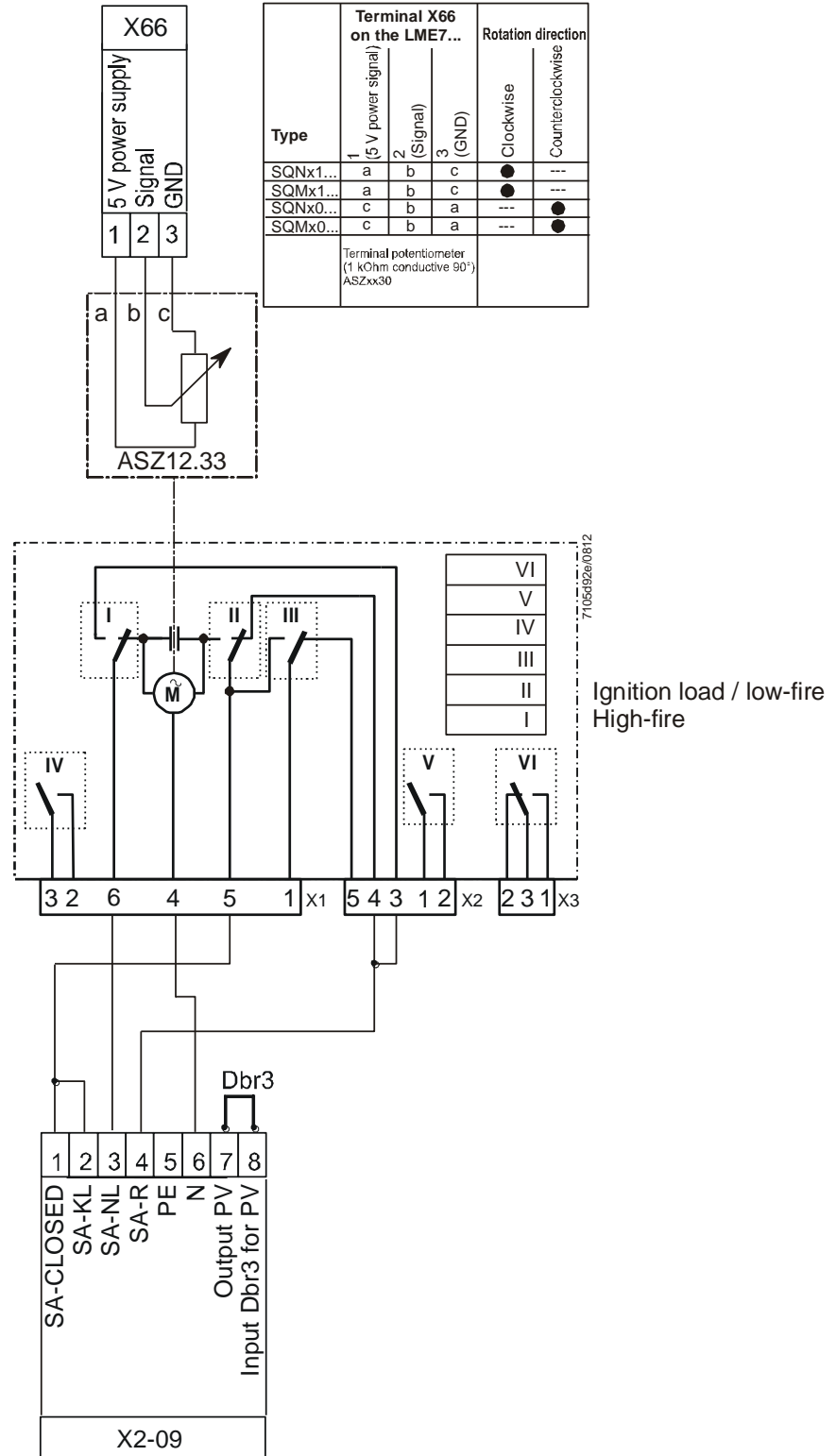

Figure 7: Connection diagram for LME73.000... with actuator SQM4...

## 12 Time table and settings

Type	Times in seconds															
	tw	TSA max.	t1 P225 4) min.	t3n P257 approx.	t4 P230 min.	t5 P232 min.	t8 P234 5) min.	t9 P231 approx.	t10 approx.	t11 P259 approx.	t12 P260 approx.	t22	2)	3)	td1 P243 td2 P245 min.	td3 P244 td4 P242 max.
Requirements	2.5	5	30	4.4	3	2	15	10	15	60	60	---	---	---	10	3
Factory setting	---	t3n+0.45	29.106+2.1	4.116+0.3	3.234	2.058	19.404	9.996	15	58.212	58.212	t9+P254(1/3)	---	---	10.29	2.646
Max.	2.5	14	1237+2.1	13.23+0.3	74.97	74.97	1237	74.97	---	1237	1237	---	0.45	0.45	37.485	2.646
Min.	---	---	0+2.1	0+0.3	3.234	2.058	0	0	---	0	0	---	0.3	---	1.029	0
Step size	---	---	4.851	0.147	0.294	0.294	4.851	0.294	---	4.851	4.851	---	---	---	0.147	0.147

Function parameter	Parameter number	Factory setting
Actuator running time to low-fire position in the event of shutdown	212	58,212 seconds
POC function 0: Inactive 1: Active (test during startup and shutdown → not safety relevant) 2: Active (test during startup and shutdown, as well as when switching to operating mode → safety relevant)	237	1
Intermittent operation after 24 hours of continuous operation 0: OFF 1: ON	239	0
Repetition in the event of lost of flame during operation 0: None 1: None 2: 1 x repetition	240	0
Valve proving 0 = OFF 1 = ON	241	1
Continuous pilot (during operation) 0 = OFF 1 = ON	247	0
Reaction time flame error or air pressure switch error 0: 1 second 1: 3 seconds	254	1 1)



- 1) **Caution!**  
**Factory setting:**  
**Parameter 254 → Response time in case of loss of flame 3 seconds!**  
**For a response time about 1 second, the parameter 254 must be changed.**

## Legend

tw Waiting time  
TSA Safety time  
t1 Prepurge time  
t3n Postignition time parameter 257 +0.3 seconds  
t4 Interval: End of safety time – fuel valve V1 and fuel valve V2 ON  
t5 Interval: Pilot valve OFF - load controller release  
t8 Postpurge time  
t9 Interval: Fuel valve V1 ON and pilot valve OFF  
t10 Specified time air pressure switch message (timeout)  
t11 Opening time of actuator (timeout)  
t12 Closing time of actuator (timeout)  
t22 2<sup>nd</sup> safety time

td1 Test time atmospheric pressure  
td2 Test time gas pressure  
td3 Test space filling  
td4 Test space evacuating

- 1) Reaction time to a change of signal by the air pressure switch contact (opens) and flame-out response time in the event of loss of flame
- 2) Reaction time to a change of signal by the inputs (e.g. pressure switch-min)
- 3) Flame detection time
- 4) Minimum time  $td1 + td2 + td3 + td4$  if: Parameter 241 = 1 (ON, after mains ON, with lockout, parameter 234 (postpurge time) = 0 (postpurging)
- 5) Minimum time  $td1 + td2 + td3 + td4$  if: Parameter 241 = 1 (ON) and parameter 234 (postpurge time) >0 (postpurging)



# 13 Inputs and outputs / internal connection diagram

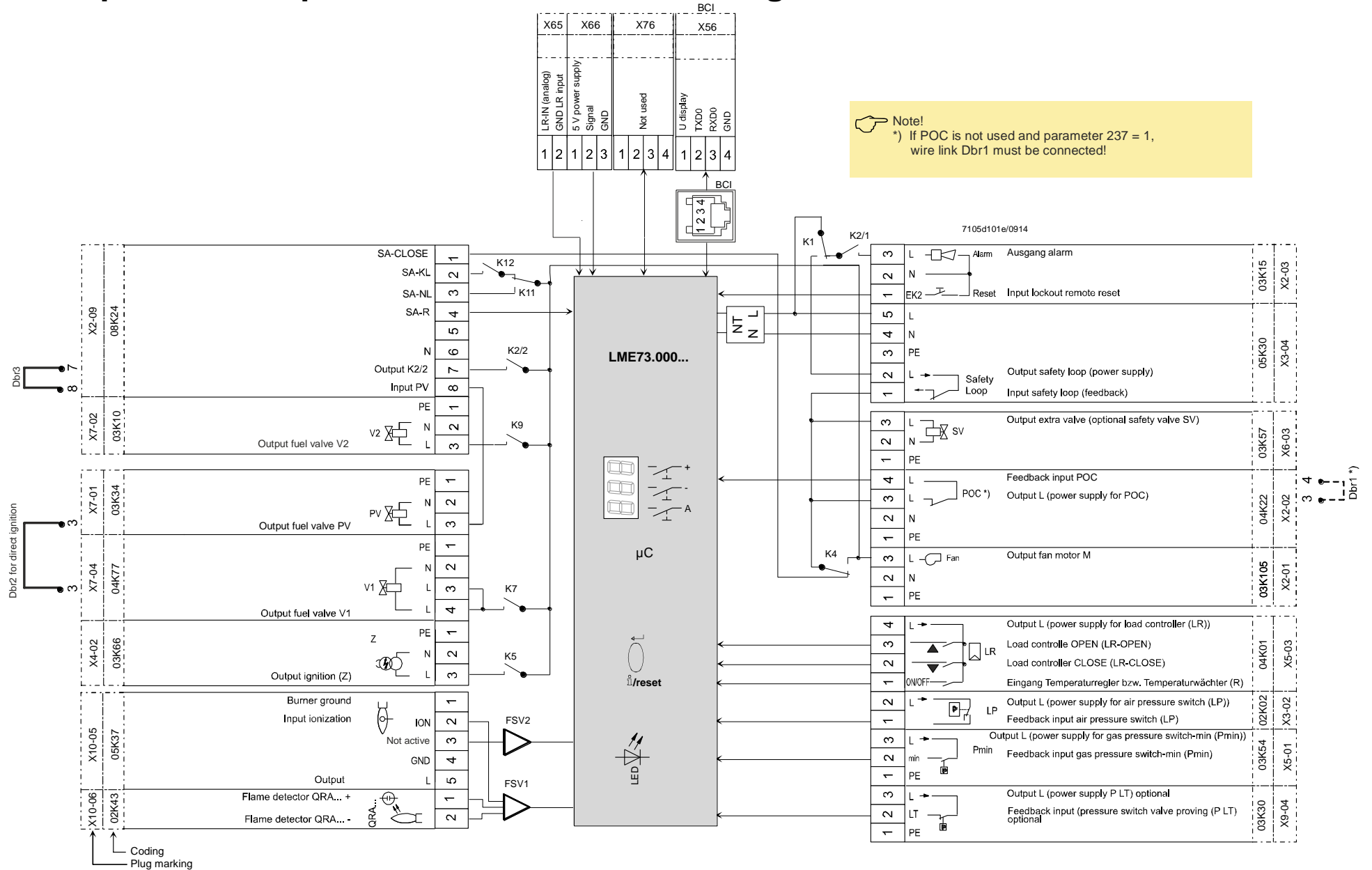

Figure 8: Inputs and outputs / internal connection diagram

## 14 Parameter list (AZL2...)

Parameter number	Parameter	Edit	Value range		Increment	Factory setting	Password level reading from level	Password level writing from level
			Min.	Max.				
<b>000</b>	<b>Internal parameter</b>							
41	Heating engineer (HF) password (4 characters)	Edit	xxxx	xxxx	---	---	---	OEM
42	OEM password (5 characters)	Edit	xxxxx	xxxxx	---	---	---	OEM
60	Backup/restore	Edit	Restore	Backup	---	---	---	SO
<b>100</b>	<b>General</b>							
102	Identification date	Read only	---	---	---	---	Info	---
103	Identification number	Read only	0	9999	1	0	Info	---
113	Burner identification	AZL2: Readable ACS410: Selectable	0	99999999	1	-----	Info	OEM via ACS410
123	Min. power control step	Edit	1%	10%	0,1	2	SO	SO
140	Mode display of display and operating unit AZL2... 1 = standard (program phase) 2 = flame 1 (QRA.../ION) 3 = flame 2 (QRB.../QRC...) ⇒ not used 4 = active power (power value)	Edit	1	4	1	1	SO	SO
164	Number of startups resettable	Resettable	0	999999	1	0	Info	Info
166	Total number of startups	Read only	0	999999	1	0	Info	---
170.00	Switching cycles relay contact K12	Read only	0	999999	1	0	Info	---
170.01	Switching cycles relay contact K11	Read only	0	999999	1	0	Info	---
170.02	Switching cycles relay contact K2	Read only	0	999999	1	0	Info	---
170.03	Switching cycles relay contact K1	Read only	0	999999	1	0	Info	---
171	Max. switching cycles relay	Read only	0	999999	1	0	Info	---





Parameter number	Parameter	Edit	Value range		Increment	Factory setting	Password level reading from level	Password level writing from level
			Min.	Max.				
<b>200</b>	<b>Burner control</b>							
212	Actuator running time to low-fire position in the event of shutdown	Edit	0 s	1237 s	4,851 s	58,212 s	SO	SO
225	Prepurge time -2,1 seconds	Edit	0 s	1237 s	4,851 s	29,106 s	SO	OEM
230	Interval: End of safety time - fuel valve V1 and fuel valve V2 ON	Edit	3,234 s	74,97 s	0,294 s	3,234 s	SO	OEM
231	Interval: Fuel valve V1 and fuel valve V2 ON – pilot valve OFF	Edit	0 s	74,97 s	0,294 s	9,996 s	SO	OEM
232	Interval: Pilot valve OFF – load controller release	Edit	2,058 s	74,97 s	0,294 s	2,058 s	SO	OEM
234	Postpurge time	Edit	0 s	1237 s	4,851 s	19,404 s	SO	OEM
237	POC function 0: Inactive 1: Active (test during startup and shutdown (not safety relevant)) 2: Active (test during startup and shutdown, as well as when switching to operating mode (safety relevant))	Edit	0	2	1	1	SO	SO
239	Intermittent operation after 24 hours of continuous operation 0 = OFF 1 = ON	Edit	0	1	1	0	SO	OEM
240	Repetition in the event of loss of flame during operation 0 = none 1 = none 2 = 1 x Repetition	Edit	0	2	1	0	SO	OEM
241	Valve proving 0 = OFF 1 = ON	Edit	0	1	1	1	SO	OEM
242	Valve proving - test space evacuating	Edit	0 s	2,648 s	0,147 s	2,648 s	SO	OEM
243	Valve proving - test time atmospheric pressure	Edit	1,029 s	37,485 s	0,147 s	10,290 s	SO	OEM
244	Valve proving - test space filling	Edit	0 s	2,648 s	0,147 s	2,648 s	SO	OEM
245	Valve proving - test time gas pressure	Edit	1,029 s	37,485 s	0,147 s	10,290 s	SO	OEM
247	Continuous pilot (during operation) 0 = OFF 1 = ON	Edit	0	1	1	0	SO	OEM
254	Reaction time to loss of flame / fault air pressure switch 0 = 1 s 1 = 3 s	Edit	0	1	1	1	SO	OEM
257	Postignition time -0.3 seconds	Edit	0 s	13,23 s	0,147 s	4,116 s	SO	OEM
259	Opening time of actuator (timeout)	Edit	0 s	1237 s	4,851 s	58,212 s	SO	OEM
260	Closing time of actuator (timeout)	Edit	0 s	1237 s	4,851 s	58,212 s	SO	OEM

Parameter number	Parameter	Edit	Value range		Increment	Factory setting	Password level reading from level	Password level writing from level
			Min.	Max.				
<b>600</b>	<b>Power setting</b>							
654	Analog input (feedback potentiometer ASZxx.3x required) 0 = 3-position step input 1 = 0...10 V 2 = 0...135 Ω 3 = 0...20 mA 4 = 4...20 mA with lockout at I <4 mA 5 = 4...20 mA	Edit	0	5	1	1	SO	SO
<b>700</b>	<b>Error history</b>							
701	Current error: 00: Error code 01: Startup meter reading 02: HMI phase 03: Power value	Read only	2 0 --- 0%	255 999999 --- 100%	1 1 --- 1	---	Service	---
702	Error history former 1: 00: Error code 01: Startup meter reading 02: HMI phase 03: Power value	Read only	2 0 --- 0%	255 999999 --- 100%	1 1 --- 1	---	Service	---
• • •								
711	Error history former 10: 00: Error code 01: Startup meter reading 02: HMI phase 03: Power value	Read only	2 0 --- 0%	255 999999 --- 100%	1 1 --- 1	---	Service	---
<b>900</b>	<b>Process data</b>							
936	Normalized speed	Read only	0%	100%	0,01%	---	Service	---
951	Mains voltage	Read only	0 V	LME73.000x1...: 175 V LME73.000x2...: 350 V	1 V	---	Service	---
954	Flame intensity	Read only	0%	100%	1%	---	Service	---

# 15 Error code list

Error code		Clear text	Possible causes
AZL2...	7-Segment		
Loc: 2	Loc 2	No establishment of flame at the end of safety time	<ul style="list-style-type: none"> <li>- Faulty or soiled fuel valves</li> <li>- Faulty or soiled flame detector</li> <li>- Poor adjustment of burner, no fuel</li> <li>- Faulty ignition equipment</li> </ul>
Loc: 3	Loc 3	Air pressure faulty (air pressure switch welded in no-load position, decrease to specified time (air pressure switch flame-on response time))	Air pressure switch faulty <ul style="list-style-type: none"> <li>- Loss of air pressure signal after specified time</li> <li>- Air pressure switch has welded in no-load position</li> </ul>
Loc: 4	Loc 4	Extraneous light	Extraneous light during burner startup
Loc: 5	Loc 5	Air pressure faulty, air pressure switch welded in working position	Time supervision air pressure switch <ul style="list-style-type: none"> <li>- Air pressure switch has welded in working position</li> </ul>
Loc: 6	Loc 6	Fault of actuator	<ul style="list-style-type: none"> <li>- Actuator faulty or blocked</li> <li>- Faulty connection</li> <li>- Wrong adjustment</li> </ul>
Loc: 7	Loc 7	Loss of flame	Too many losses of flame during operation (limitation of repetitions) <ul style="list-style-type: none"> <li>- Faulty or soiled fuel valves</li> <li>- Faulty or soiled flame detector</li> <li>- Poor adjustment of burner</li> </ul>
Loc: 10	Loc 10	Error not relatable (application), internal error	Wiring error or internal error, output contacts, other faults
Loc: 12	Loc 12	Valve proving	Fuel valve V1 leaking
Loc: 13	Loc 13	Valve proving	Fuel valve V2 leaking
Loc: 14	Loc 14	POC error	Error valve closure control POC
Loc: 20	Loc 20	Gas pressure switch-min open	Gas shortage
Loc: 22	Loc 22	Safety loop open	<ul style="list-style-type: none"> <li>- Gas pressure switch-max open</li> <li>- Safety limit thermostat cut out</li> </ul>
Loc: 60	Loc 60	Analog power source 4...20 mA, I <4 mA	Wire breakage
Loc: 138	Loc 138	Restore process successful	Restore process successful
Loc: 139	Loc 139	No program module detected	No program module plugged in
Loc: 167	Loc 167	Manual locking	Manual locking
Loc: 206	Loc 206	AZL2... incompatible	Use the latest version
rSt Er1	rSt Er1	Error in compatibility program module to LME7 during restore process	Program sequence of program module does not match the LME7
rSt Er2	rSt Er2	Error in compatibility program module to LME7 during restore process	Hardware of LME7 does not match the program module
rSt Er3	rSt Er3	Error during restore process	<ul style="list-style-type: none"> <li>- Program module faulty</li> <li>- Program module removed during restore process</li> </ul>
bAC Er3	bAC Er3	Fault of compatibility program module to LME7 during backup process	Program sequence of program module does not match the LME7
Err PrC	Err PrC	Fault of program module	<ul style="list-style-type: none"> <li>- Error in data content of program module</li> <li>- No program module fitted</li> </ul>

# 16 Legend

AL	Alarm device
Dbr...	Wire link
 reset (EK1)	Lockout reset button (info button)
EK2	Remote lockout reset button
FSV	Flame signal amplifier
ION	Ionization probe
K...	Relay contact
LED	3-color signal lamp
LP	Air pressure switch
LR	Load controller
LR-OPEN	Load controller OPEN position
LR-CLOSED	Load controller CLOSED position
M	Fan motor
NT	Power supply unit
P LT	Pressure switch - valve proving
Pmax	Pressure switch-max
Pmin	Pressure switch-min
POC	Valve closure control (proof of closure)
PV	Pilot valve
QRA...	Flame sensor
R	Control thermostat or pressurestat
SA	Actuator
SA-KL	Actuator low-fire
SA-NL	Actuator high-fire
SA-R	Actuator feedback
SA-ZU	Actuator CLOSED
SA-ZL	Actuator ignition load
SK	Safety Loop
SV	Safety valve
V1	Fuel valve
V2	Fuel valve
Z	Ignition transformer
	Input/output signal 1 (ON)
	Input/output signal 0 (OFF)
	Permissible input signal 1 (ON) or 0 (OFF)

# 17 List of figures

---

Figure 1: Program sequence .....	5
Figure 2: Program sequence .....	6
Figure 3: Fuel train gas direct ignition (G), 1-stage .....	9
Figure 4: Fuel train gas pilot ignition 1 (Gp1/1), 1-stage .....	9
Figure 5: Fuel train gas pilot ignition 1 (Gp1/2), 1-stage, with valve proving .....	10
Figure 6: Valve proving with separate pressure switch .....	11
Figure 7: Connection diagram for LME73.000... with actuator SQM4... ..	14
Figure 8: Inputs and outputs / internal connection diagram.....	17