



## Basic Unit with integrated Fuel / Air Ratio Control for Forced Draft Burners LMV27.100...

The LMV27... is a microprocessor-based burner control with matching system components for the control and supervision of forced draft burners of medium to high capacity.

The LMV27... and this Data Sheet are intended for use by OEMs which integrate the actuators in their products!

### Use

Microprocessor-controlled basic unit for single-fuel burners of any capacity, in intermittent operation with electronic air-fuel ratio control, maximum 2 actuators and with integrated gas valve proving.

The system components (display and operating unit, actuators) are connected directly to the LMV27... basic unit. All safety-related digital inputs and outputs of the system are monitored by contact feedback network.

For Europe

For intermittent operation in connection with the LMV27..., the ionization probe or the QRA..., QRB... or QRC... optical flame detector can be used.

For North America

For intermittent operation in connection with the LMV27..., the ionization probe or the optical flame detector QRA4... can be used.

- Gas burner controls to EN 298
- For gas burners with fans conforming to EN 676
- For oil burners with fan to EN 267

## Features

---

The following components are integrated in the basic unit of the LMV27...:

- Burner management system complete with valve proving system
- Electronic fuel / air ratio control system for a maximum of 2 actuators SQM3... or SQN1...
- Modbus interface
- BCI for connection a display or PC
- Unit parameter adjustable either via display or PC software ACS410

## Notes

---



### **Warning!**

**All safety, warning and technical notes given in the Basic Documentation of the LMV27... (P7541) also apply to this document!**



**Applied directives:**

- Low-voltage directive 2014/35/EC
- Directive for gas-fired appliances 2009/142/EC
- Directive for pressure devices 97/23/EC and 2014/68/EC (2016-07-16)
- Electromagnetic compatibility EMC (immunity) \*) 2014/30/EC

\*) The compliance with EMC emission requirements must be checked after the burner management system is installed in equipment

Compliance with the regulations of the applied directives is verified by the adherence to the following standards / regulations:

- Automatic burner control systems for burners and appliances burning gaseous or liquid fuels DIN EN 298
- Safety and control devices for gas burners and gas burning appliances - Valve proving systems for automatic shut-off valves DIN EN 1643
- Gas/air ratio controls for gas burners and gas burning appliances - Part 2: Electronic types DIN EN 12067-2
- Safety and control devices for gas burners and gas burning appliances DIN EN 13611
- Safety and control devices for gas burners and gas-burning appliances - Particular requirements Part 1: Automatic and semi-automatic valves ISO 23552-1
- Automatic electrical controls for household and similar use Part 2-5: Particular requirements for automatic electrical burner control systems DIN EN 60730-2-5

**The relevant valid edition of the standards can be found in the declaration of conformity!**



**Note on DIN EN 60335-2-102**

Household and similar electrical appliances - Safety - Part 2-102: Particular requirements for gas, oil and solid-fuel burning appliances having electrical connections. The electrical connections of the LMV2 comply with the requirements of EN 60335-2-102.



EAC Conformity mark (Eurasian Conformity mark)



ISO 9001:2008  
ISO 14001:2004  
OHSAS 18001:2007



## Life cycle

---

The burner management system LMV27... has a designed lifetime\* of 250,000 burner startup cycles which, under normal operating conditions in heating mode, correspond to approx. 10 years of usage (starting from the production date given on the type field). This lifetime is based on the endurance tests specified in standard EN 298. A summary of the conditions has been published by the European Control Manufacturers Association (Afecon) ([www.afecor.org](http://www.afecor.org)).

The designed lifetime is based on use of the LMV27... according to the manufacturer's Data Sheet and Basic Documentation. After reaching the designed lifetime in terms of the number of burner startup cycles, or the respective time of usage, the LMV27... is to be replaced by authorized personnel.

\* The designed lifetime is not the warranty time specified in the Terms of Delivery

## Supplementary documentation

User documentation Modbus AZL2...	A7541
Environmental product declaration LMV2... / LMV3...	E7541
Installation and operating instructions PC software ACS410	J7352
Basic documentation LMV27...	P7541
Product range overview LMV2... / LMV3...	Q7541

## System overview

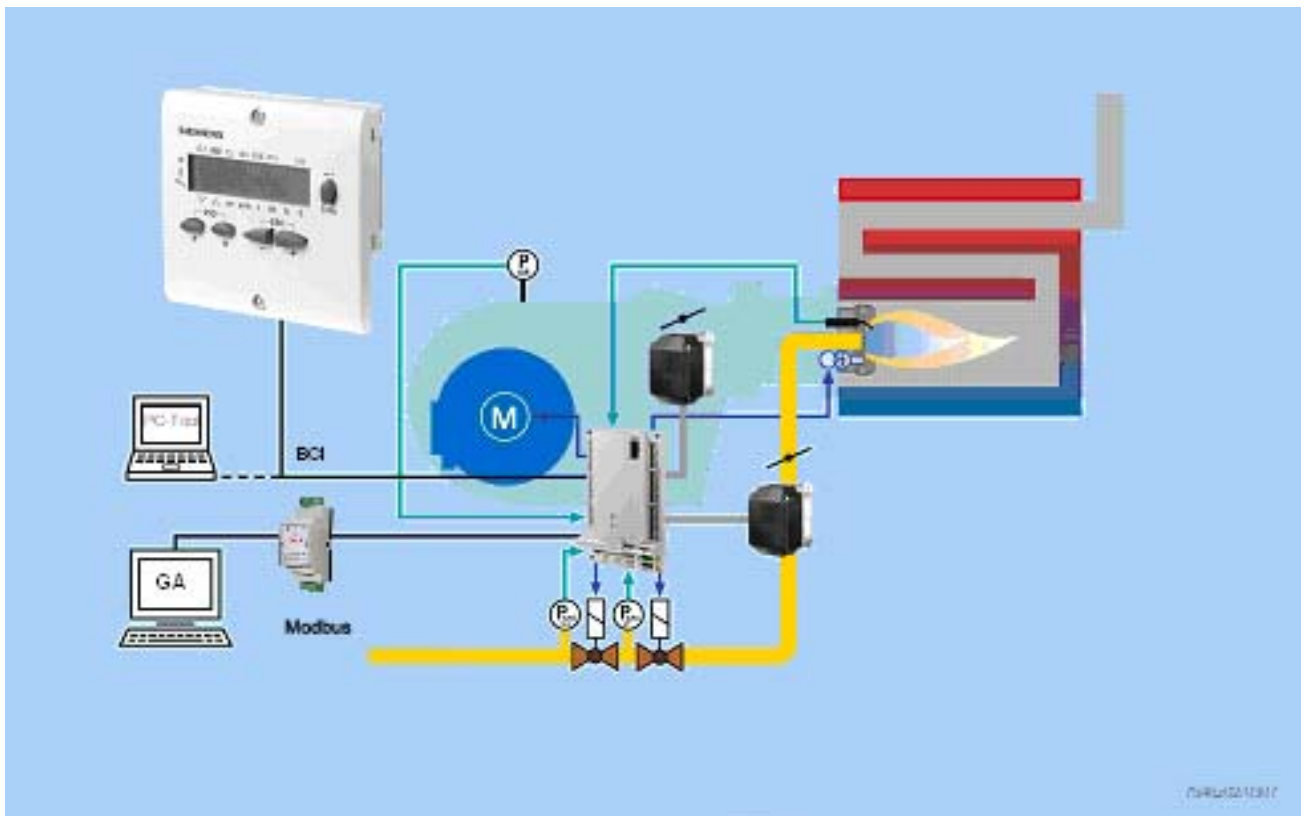

The diagram shows the full scope of functions of the LMV27... system. The actual functions are to be determined based on the respective execution / configuration!

## Ordering

### Burner control

#### LMV27...

The basic unit is the actual burner control featuring all-polar input / output terminals. No operating elements. Operation via detached ancillary units for wire-bound communication. See Basic Documentation P7541



Type	Mains voltage	Parameter set	Detectors	TSA	
				Gas	Oil
LMV27.100A2	AC 230 V	Europe	QRA2... / QRA4... / QRA10... / QRB... / QRC... / ION	3 s	5 s

### Service tools

#### OCI410... interface between burner management system and PC

Facilitates viewing, handling and recording setting parameters on site with the help of the ACS410 software package.

See Data Sheet N7616



#### OCI412.10 Modbus interface

Device serving as an interface between the LMV27... and a Modbus system, such as a building automation and control system (BACS). The Modbus interface is based on the RS-485 standard.

See Data Sheet N7615



#### ACS410

PC software for parameterization and visualization to the burner management system.

See Software Documentation J7352

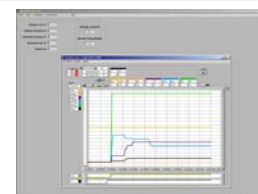

### Display and operating units

#### AZL21.00A9

Detached display and operating unit, choice of mounting methods, 8-digit LCD, 5 buttons, BCI for LMV27... system, degree of protection IP40.

See Data Sheet N7542



#### AZL23.00A9

Detached display and operating unit, choice of mounting methods, 8-digit LCD, 5 buttons, BCI for LMV27... system, degree of protection IP54.

See Data Sheet N7542



Flame detectors

**QRA2...**

Flame detector for use with Siemens burner controls, for the supervision of gas flames and yellow- / blue-burning oil flames as well as ignition spark checking. Plastic housing, metalized to prevent static charging caused by the air flow from the fan. For direct mounting on the burner. The detectors can be supplied with or without securing flange and clamp.

See Data Sheet N7712



**QRA4...**

Flame detector for use with Siemens burner controls, for the supervision of gas flames and yellow- or blue-burning oil flames as well as for ignition spark proving.

See Data Sheet N7711



**QRA10...**

Flame detector for use with Siemens burner controls, for the supervision of gas flames and yellow- / blue-burning oil flames as well as ignition spark checking.

Die-cast aluminium housing with a 1 in. mounting coupling and connection facility for cooling air. The housing of this detector has a bayonet fitting which allows it to be secured either directly to the 1 in. mounting coupling or to the AGG06. The 1 in. mounting coupling can be screwed to a viewing tube or to the AGG07. The Pg cable gland can be removed and replaced, if some other detector cable shall be used.

See Data Sheet N7712

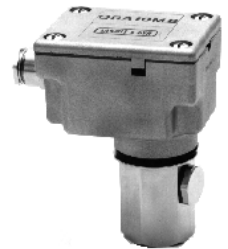

**QRB...**

Photo resistive flame detector for use with Siemens burner controls, for the supervision of oil flames in the visible light spectrum. Especially suited for use with burner controls for small capacity burners in intermittent operation.

See Data Sheet N7714



**QRC...**

Blue-flame detector for use with Siemens burner controls, for the supervision of blue- or yellow-burning oil or gas flames. Especially suited for use with burner controls for small capacity burners in intermittent operation.

See Data Sheet N7716

Frontal illumination



Lateral illumination



**Actuators**

**SQM33.4...**

Rated torque 1.2 Nm (0.8 Nm holding torque when dead),  
running time 5 s, stepper motor, front mounting, D-type drive  
shaft.

See Data Sheet N7813

**SQM33.5...**

Rated torque 3 Nm (2.6 Nm holding torque when dead),  
running time 5 s, stepper motor, front mounting, D-type drive  
shaft.

See Data Sheet N7813



**SQM33.7...**

Rated torque 10 Nm (6 Nm holding torque when dead),  
running time 17 s, stepper motor, front mounting, D-type  
drive shaft.

See Data Sheet N7813

---

**SQN1...**

Rated torque 1 Nm (0.2 Nm holding torque when dead),  
running time 5 s, stepper motor, front mounting, D-type drive  
shaft.

See Data Sheet N7803





**Connector sets**

**AGG3.131**

Complete connector set RAST2.5 / RAST3.5 / RAST5 for gas / oil applications, single pack.  
See Object List C7541 (74 319 0637 0)

Example: X5-02



**AGG3.132**

Complete connector set RAST2.5 / RAST3.5 / RAST5 for gas- / oil applications, pack of 10.  
See Object List C7541 (74 319 0637 0)

**AGG9...**

Single connectors  
Packing unit 200 in total

Example X5-03



Type	Type of connector	Terminal
<b>AGG9.203</b>	RAST5	X3-02
<b>AGG9.204</b>	RAST5	X3-03
<b>AGG9.206</b>	RAST5	X8-04
<b>AGG9.209</b>	RAST5	X10-06
<b>AGG9.217</b>	RAST5	X75
<b>AGG9.303</b>	RAST5	X3-05
<b>AGG9.304</b>	RAST5	X4-02
<b>AGG9.306</b>	RAST5	X5-01
<b>AGG9.307</b>	RAST5	X5-02
<b>AGG9.309</b>	RAST5	X6-03
<b>AGG9.310</b>	RAST5	X7-01
<b>AGG9.311</b>	RAST5	X7-02
<b>AGG9.313</b>	RAST5	X9-04
<b>AGG9.403</b>	RAST5	X5-03
<b>AGG9.406</b>	RAST5	X8-02
<b>AGG9.501</b>	RAST5	X3-04
<b>AGG9.504</b>	RAST5	X10-05
<b>AGG9.853</b>	RAST3.5	X64 and X74

**Accessories**

**AGG5.310**

Accessories set speed control, for burner management systems, composed of sensor disk Ø 50, sensor and mounting set.  
See Mounting instructions M7550.1 (74 319 9322 0)



**Cables**

**AGV50.100**

Signal cable for AZL2..., with RJ11 connector, length 1 m, pack of 10

**AGV50.300**

Signal cable for AZL2..., with RJ11 connector, length 3 m, pack of 10



**Proportional controlling element with mounting plate**

**VKP**

Proportional controlling element for mounting between threaded flanges in gas trains.  
Refer to Data Sheet N7646



**ASK33.1**

Larger mounting plate required to replace existing mounting plate. Required for mounting the actuators SQM4 or SQM33.  
Refer to Data Sheet N7646



**ASK33.2**

Additional mounting plate is required for mounting the actuator SQN13.  
Refer to Data Sheet N7646



**Gas damper for mounting kit**

**VKF41...C**

Butterfly valves designed in intermediate flange design, for integration into gas trains.  
Refer to Data Sheet N7632



**ASK33.4**

Mounting kit for mounting the actuators SQM33.5 on the butterfly valve VKF41...C.  
Refer to Data Sheet N7632



**Transformer**

**A5Q20002669**

Transformer to increase ionization voltage for AC 120 V devices.  
See User Documentation A7541.2



# Connection and internal diagram LMV27...

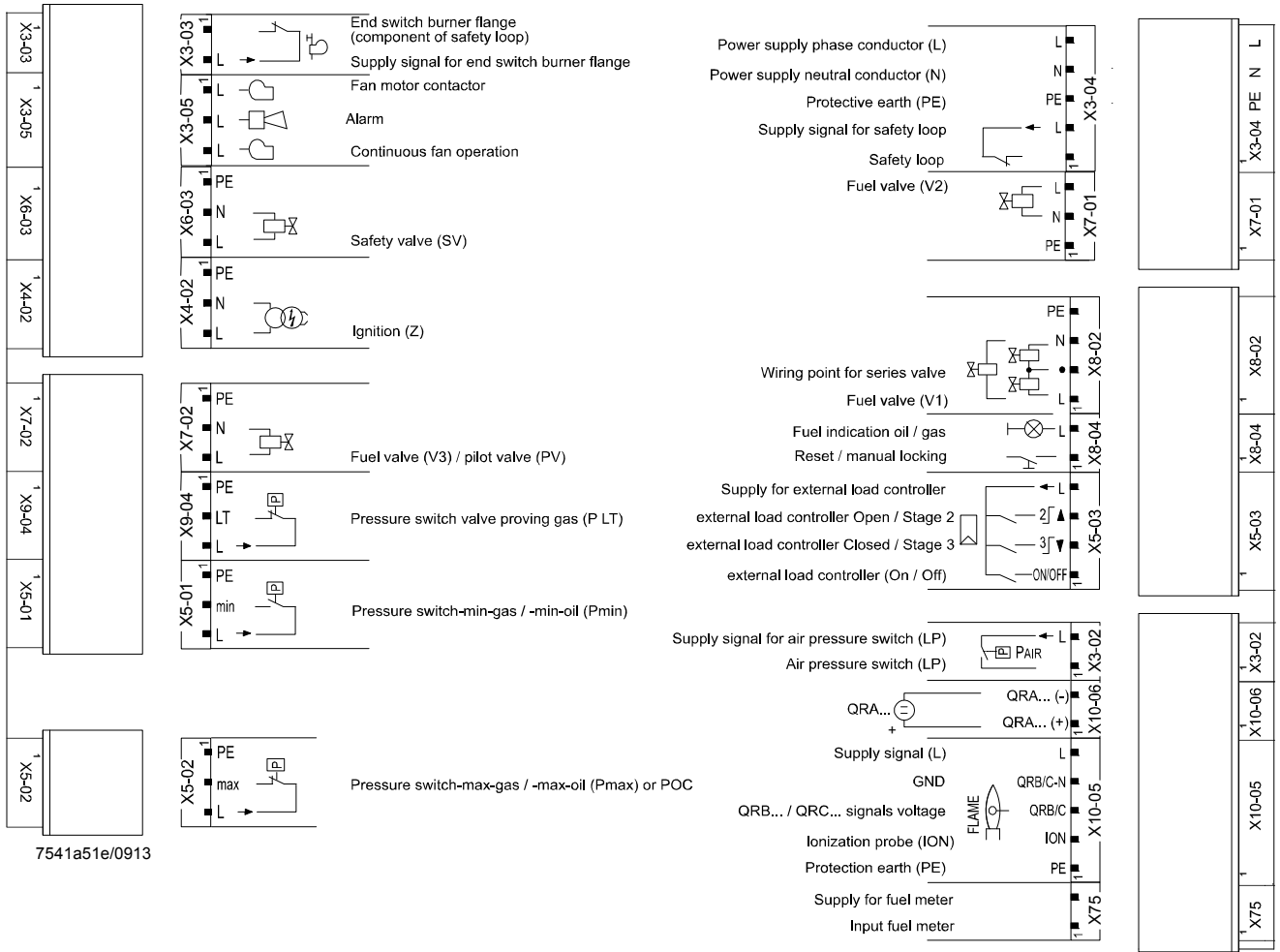

7541a51e/0913

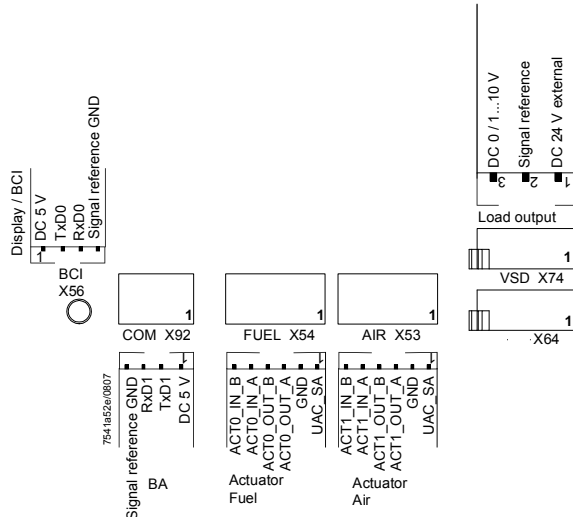

## Technical Data

### LMV27... basic unit

General	Mains voltage	AC 230 V -15% / +10%
	Mains frequency	50 / 60 Hz $\pm$ 6%
	Power consumption	<30 W (typically)
	Safety class	I with parts according to II and III to DIN EN 60730-1
	Degree of protection	IP00
		<p><b>Note</b> The burner or boiler manufacturer must ensure degree of protection IP40 for LMV27... as per DIN EN 60529 through adequate installation.</p>
Terminal loading «Inputs»	<ul style="list-style-type: none"> <li>Perm. mains primary fuse (externally)</li> </ul>	Max. 16 AT
	<ul style="list-style-type: none"> <li>Unit fuse F1 (internal)</li> </ul>	6,3 AT (DIN EN 60127 2 / 5)
	<ul style="list-style-type: none"> <li>Mains supply: Input current depending on the operating state of the unit</li> </ul>	
	Undervoltage	
	<ul style="list-style-type: none"> <li>Safety shutdown from operating position at mains voltage</li> </ul>	Approx. AC 186 V
	<ul style="list-style-type: none"> <li>Restart on rise in mains voltage</li> </ul>	Approx. AC 195 V
	Status inputs: Status inputs (with the exception of the safety loop) of the contact feedback network (CFN) are used for system supervision and require mains-related input voltage	
	<ul style="list-style-type: none"> <li>Input safety loop</li> </ul>	Refer to <i>Terminal loading outputs</i>
	<ul style="list-style-type: none"> <li>Input currents and input voltages</li> </ul>	
	<ul style="list-style-type: none"> <li>- UeMax</li> </ul>	UN +10 %
	<ul style="list-style-type: none"> <li>- UeMin</li> </ul>	UN -15 %
	<ul style="list-style-type: none"> <li>- IeMax</li> </ul>	1.5 mA peak
	<ul style="list-style-type: none"> <li>- IeMin</li> </ul>	0.7 mA peak
	<ul style="list-style-type: none"> <li>Contact material recommendation for external signal sources (LP, Pmin, Pmax, etc.)</li> </ul>	Gold-plated silver contacts
	<ul style="list-style-type: none"> <li>Transition / settling behavior / bounce</li> </ul>	
<ul style="list-style-type: none"> <li>- Perm. bounce time of contacts when switching on / off</li> </ul>	Max. 50 ms (after the bounce time, contact must stay closed or open)	
<ul style="list-style-type: none"> <li>UN</li> </ul>	AC 230 V	
<ul style="list-style-type: none"> <li>Voltage detection</li> </ul>		
<ul style="list-style-type: none"> <li>- On</li> </ul>	AC 180...253 V	
<ul style="list-style-type: none"> <li>- Off</li> </ul>	<AC 80 V	

**Technical Data (cont'd)**Terminal loading  
«Outputs»**Total contact loading:**

- |  |                      |
|--|----------------------|
| • Rated voltage                          | AC 230 V, 50 / 60 Hz |
| • Unit input current (safety loop) from: | Max. 5 A             |
| - Fan motor contactor                    |                      |
| - Ignition transformer                   |                      |
| - Valves                                 |                      |
| - Oil pump / magnetic clutch             |                      |

**Individual contact loading:**

## Fan motor contactor

- |                 |                      |
|-----------------|----------------------|
| • Rated voltage | AC 230 V, 50 / 60 Hz |
| • Rated current | 2 A                  |
| • Power factor  | $\cos\varphi > 0.4$  |

## Alarm output

- |                 |                      |
|-----------------|----------------------|
| • Rated voltage | AC 230 V, 50 / 60 Hz |
| • Rated current | 1 A                  |
| • Power factor  | $\cos\varphi > 0.4$  |

## Ignition transformer

- |                 |                      |
|-----------------|----------------------|
| • Rated voltage | AC 230 V, 50 / 60 Hz |
| • Rated current | 2 A                  |
| • Power factor  | $\cos\varphi > 0.2$  |

## Fuel valves

- |                 |                      |
|-----------------|----------------------|
| • Rated voltage | AC 230 V, 50 / 60 Hz |
| • Rated current | 2 A                  |
| • Power factor  | $\cos\varphi > 0.4$  |

## Operation display

- |                 |                      |
|-----------------|----------------------|
| • Rated voltage | AC 230 V, 50 / 60 Hz |
| • Rated current | 0.5 A                |
| • Power factor  | $\cos\varphi > 0.4$  |

## Safety valve (SV) (magnetic clutch / oil pump)

- |                 |                      |
|-----------------|----------------------|
| • Rated voltage | AC 230 V, 50 / 60 Hz |
| • Rated current | 2 A                  |
| • Power factor  | $\cos\varphi > 0.4$  |

## Connections for pressure switch

- |                 |                      |
|-----------------|----------------------|
| • Rated voltage | AC 230 V, 50 / 60 Hz |
| • Rated current | 1.5 mA               |
| • Power factor  | ---                  |

Analog output / load  
output X74 pin 3

Accuracy of output voltage	$\pm 1 \%$
----------------------------	------------

## Technical Data (cont'd)

Cable lengths	• Mains line AC 230 V	Max. 100 m (100 pF/m)
	• Display, BCI	For installation under the burner hood or in the control panel Max. 3 m (100 pF/m)
	• Load controller (LR) X5-03	Max. 20 m (100 pF/m)
	• Safety loop / burner flange (total)	Max. 20 m (100 pF/m)
	• External lockout reset button	Max. 20 m (100 pF/m)
	• Safety valve (SV)	Max. 20 m (100 pF/m)
	• Load output <sup>1)</sup>	Max. 10 m (100 pF/m)
	• Fuel valve (V1 / V2 / V3)	Max. 3 m (100 pF/m)
	• Pilot valve (PV)	Max. 3 m (100 pF/m)
	• Ignition transformer (Z)	Max. 3 m (100 pF/m)
	• Other lines	Max. 3 m (100 pF/m)

<sup>1)</sup> Do not run the cable together with other cables. If not observed, hum voltage might cause electromagnetic interference

### Specification as per EN 60730-1

Type of shutdown or interruption of each circuit

Shutdown with microswitch 1-pole

Mode of operation Type 2 B

Cross-sectional areas The cross-sectional areas of the mains power lines (L, N, and PE) and, if required, the safety loop (safety limit thermostat, water shortage, etc.) must be sized for rated currents according to the selected external primary fuse. The cross-sectional areas of the other cables must be sized in accordance with the internal unit fuse (max. 6.3 AT).

Min. cross-sectional area	0.75 mm <sup>2</sup> (single- or multi-core as per VDE 0100)
---------------------------	---

Cable insulation must meet the relevant temperature requirements and environmental conditions.

Fuses used inside the LMV27... basic unit - F1	6,3 AT DIN EN 60127 2 / 5
---	---------------------------

**Electrical connections of actuators** The fixed connected actuator cables must not be extended.

**AGV50... signal cable**  
AZL2... → BCI

<b>Signal cable</b>	Color white Unshielded Conductor 4 x 0.141 mm <sup>2</sup> With RJ11-plug
Cable length	
- AGV50.100	1 m
- AGV50.300	3 m
Other cable lengths	
- Supplier	Recommended:  Hütter <a href="http://www.hkt-netzwerktechnik.at/index.htm">http://www.hkt-netzwerktechnik.at/index.htm</a>
Location	Under the burner hood (extra measures required for SKII EN 60730-1)

## Technical Data (cont'd)

---

### Environmental conditions

<b>Storage</b>	DIN EN 60721-3-1
Climatic conditions	Class 1K3
Mechanical conditions	Class 1M2
Temperature range	-20...+60 °C
Humidity	<95 % r.h.
<b>Transport</b>	DIN EN 60721-3-2
Climatic conditions	Class 2K2
Mechanical conditions	Class 2M2
Temperature range	-30...+60 °C
Humidity	<95 % r.h.
<b>Operation</b>	DIN EN 60721-3-3
Climatic conditions	Class 3K3
Mechanical conditions	Class 3M3
Temperature range	-20...+60 °C
Humidity	<95 % r.h.



#### Caution!

Condensation, formation of ice and ingress of water are not permitted!

## Technical Data (cont'd)

### Flame supervision with ionization probe

No-load voltage at ION terminal (X10-05 pin 2)	Approx. $U_{Mains}$
--	---------------------



**Caution!**  
Protect the ionization probe against electric shock hazard!

Short-circuit current	Max. AC 1 mA
Required detector current	Min. DC 4 $\mu$ A, flame display approx. 30 %
Possible detector current	Max. DC 16...40 $\mu$ A, flame display approx. 100 %
Max. perm. length of detector cable (laid separately)	3 m (wire-ground 100 pF/m)



**Warning!**  
Simultaneous operation of QRA... and ionization probe is not permitted!



#### Note

The higher the detector cable's capacitance (cable length), the more voltage at the ionization probe, and thus the detector current, drops. Long cable lengths plus very highly resistive flames might necessitate low-capacitance detector cables (e.g. ignition cable). In spite of technical measures taken in the circuitry aimed at compensating potential adverse effects of the ignition spark on the ionization current, it must be made certain that the minimum detector current required will already be reached during the ignition phase. If this is not the case, the connections on the primary side of the ignition transformer must be changed and / or the electrodes relocated.

Threshold values when flame is supervised by an ionization probe:

- Start prevention (extraneous light)	Flame intensity (parameter 954) $\geq 18$ %
- Operation	Flame intensity (parameter 954) $> 24$ %

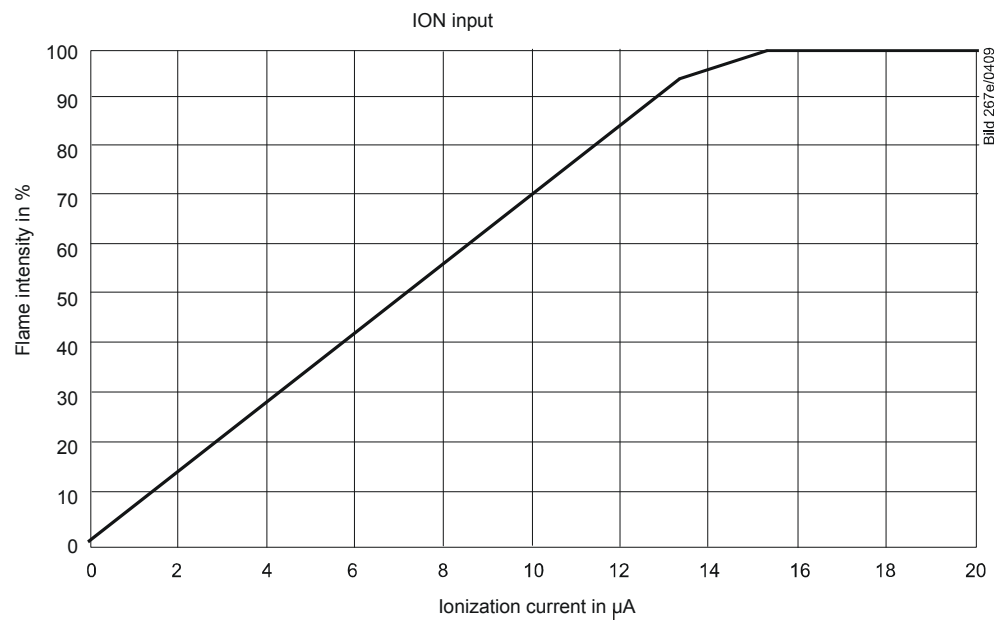



## Technical Data (cont'd)

Measuring circuit for detector current measurement

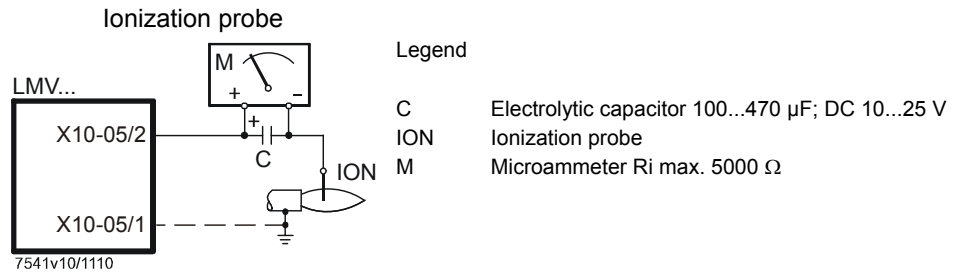

Flame supervision with QRA2... / QRA4... / QRA10...



### Warning!

If flame detectors QRA2... / QRA4... / QRA10... are used for flame supervision with the LMV27..., it must be ensured that the basic unit is permanently connected to power (conforming to EN 298), thus enabling the system to detect flame detector failures during startup and shutdown. Generally, the system works with QRA... flame detectors in intermittent operation.

**Technical Data refer to Data Sheet N7712 covering UV flame detectors QRA2... / QRA10...!**

**Technical Data refer to Data Sheet N7711 covering UV flame detectors QRA4...!**

Operating voltage	Max. 350 V peak
Required detector current in operation	Min. 70 µA
Possible detector current in operation	Max. 600 µA
Permissible length of flame detector cable - normal cable (laid separately)	Max. 20 m

Threshold values when flame is supervised by QRA...:

- Start prevention (extraneous light)	Flame intensity (parameter 954) ≥18 %
- Operation	Flame intensity (parameter 954) >24 %

Measuring circuit for detector current measurement

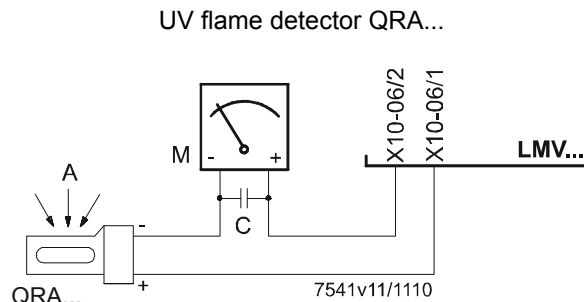

Legend

- A Incidence of light  
 C Electrolytic capacitor 100...470 µF; DC 10...25 V  
 M Microammeter Ri max. 5000 Ω



### Warning!

- **Input QRA... is not short-circuit-proof!**  
Short-circuits of X10-06 pin 2 against earth can destroy the QRA... input
- **Simultaneous operation of QRA... and ionization probe is not permitted!**

**Flame supervision with QRB...**

No-load voltage at QRB... terminal (X10-05 pin 3)	Approx. DC 5 V
Max. perm. length of QRB... detector cable (laid separately)	3 m (wire – wire 100 pF/m)

 **Note**  
 A detector resistance of  $R_F < 500 \Omega$  is identified as a short-circuit and leads to safety shutdown in operation as if the flame had been lost.

For this reason, before considering the use of a highly sensitive photoresistive detector (QRB1B... or QRB3S), it should be checked whether this type of flame detector is indeed required! Increased line capacitance between QRB... connection and mains live wire *L* has an adverse effect on the sensitivity and increases the risk of damaged flame detectors due to overvoltage. Always run detector cables separately!

Threshold values when flame is supervised by QRB...:	
Start prevention (extraneous light) with <b>RQRB</b>	Approx. 400 kΩ Flame intensity $\geq 10 \%$
Operation with <b>RQRB</b>	Approx. 230 kΩ Flame intensity $> 16 \%$
Short-circuit detection with <b>RQRB</b>	$< 0,5 \text{ k}\Omega$

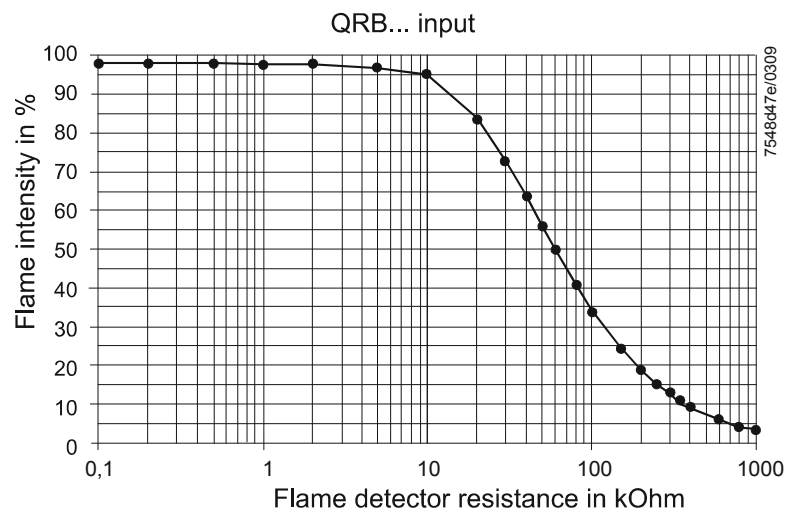

A flame detector resistance of  $R_F < 500 \Omega$  is identified as a short-circuit and leads to safety shutdown in operation, like in the case of loss of flame.

**Flame supervision with QRC...**

Check the intensity of flame with the AZL2...

For system-specific reasons, the display of maximum flame intensity by the AZL2... of maximum intensity is limited to approx. 55 %.



**Note!**  
Flame detectors QRC... are only suited for AC 230 V operation.

Threshold values when flame is supervised by QRC...:

- Start prevention (extraneous light)	Flame intensity (parameter 954) $\geq 10$ %
- Operation	Flame intensity (parameter 954) $> 16$ %

Required detector current (with flame)	Min. 70 $\mu$ A
Possible detector current (without flame)	Max. 5,5 $\mu$ A
Permissible detector current with flame	Max. 100 $\mu$ A

The values given in the table above only apply under the following conditions:

- Mains voltage AC 230 V
- Ambient temperature 23 °C

Start prevention (extraneous light) with IQRC	Ca. 15 $\mu$ A, display approx. 10 %
Operation with IQRC	Ca. 25 $\mu$ A, display approx. 16 %

Measuring circuit for detector current measurement

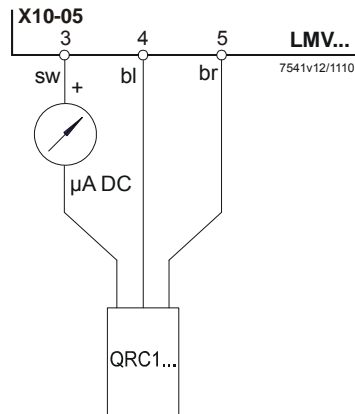

Legend

- $\mu$ A DC    DC-Mikroampèremeter an internal resistance of  $R_i = \text{max. } 5\text{k}\Omega$
- bl        blue
- sw        black
- br        brown

# Dimensions

Dimensions in mm

LMV27...

